

ENGINE	STD	OPT
Cummins QSB 6.7 engine	●	
HYDRAULIC SYSTEM		
Intelligent Power Control (IPC)		
3-power mode, 2-work mode, user mode	●	
Variable Power Control	●	
Pump Flow Control	●	
Attachment Mode Flow Control		●
Engine Auto Idle	●	
Engine Auto Shutdown Control		●
Electronic Fan Control	●	
CAB & INTERIOR		
ISO Standard cabin		
Rise-up type windshield wiper	●	
Radio / USB player	●	
Handsfree mobile phone system with USB	●	
12 volt power outlet (24V DC to 12V DC converter)	●	
Electric horn	●	
All-weather steel cab with 360° visibility	●	
Safety glass windows	●	
Sliding fold-in front window	●	
Sliding side window(LH)	●	
Lockable door	●	
Hot & cool box	●	
Storage compartment & Ashtray	●	
Transparent cabin roof-cover	●	
Sun visor	●	
Door and cab locks, one key	●	
Mechanical suspension seat with heater	●	
Pilot-operated slidable joystick	●	
Console box height adjust system	●	
Automatic climate control		
Air conditioner & heater	●	
Defroster	●	
Starting Aid (air grid heater) for cold weather	●	
Centralized monitoring		
8" LCD display	●	
Engine speed or Trip meter/Accel.	●	
Engine coolant temperature gauge	●	
Max power	●	
Low speed/High speed	●	
Auto idle	●	
Overload	●	
Check Engine	●	
Air cleaner clogging	●	
Indicators	●	
ECO Gauges	●	
Fuel level gauge	●	
Hyd. oil temperature gauge	●	
Fuel warmer	●	
Warnings	●	
Communication error	●	
Low battery	●	
Clock	●	
Cabin lights		●
Cabin front window rain guard		●
Cabin roof-steel cover		●
Seat		
Adjustable air suspension seat with heater		●
Cabin FOPS/FOG (ISO/DIS 10262) Level 2		
FOPS (Falling Object Protective Structure) · ISO 3,449 Level 2		●
FOG (Falling Object Guard)		●
Cabin ROPS (ISO 12117-2)		
ROPS (Roll Over Protective Structure)	●	

SAFETY	STD	OPT
Battery master switch	●	
Rearview camera		●
Four front working lights	●	
Travel alarm		●
Rear work lamp		●
Beacon lamp		●
Automatic swing brake	●	
Boom holding system	●	
Arm holding system	●	
Safety lock valve for boom cylinder with overload warning device		●
Safety lock valve for arm cylinder		●
Swing Lock System		●
Two outside rearview mirror	●	
OTHER		
Booms		
5.68 m mono, 18' 8"	●	
5.65 m 2-piece, 18' 6"		
Arms		
2.0 m, 6' 7"		●
2.4 m, 7' 10"		●
2.92 m, 9' 7"	●	
Removable clean-out dust net for cooler	●	
Removable reservoir tank	●	
Fuel pre-filter	●	
Fuel warmer (Single)	●	
Fuel warmer (Dual)		●
Self-diagnostics system	●	
Hi-mate (Remote Management System)		●
Batteries (2 x 12V x 100 AH)	●	
Fuel filler pump (50 L/min)		●
Single-acting piping kit (breaker, etc.)		●
Double-acting piping kit (clamshell, etc.)		●
Rotating Piping Kit		●
Quick coupler piping		●
Quick coupler		●
One Pedal Straight Travel System		●
Accumulator for lowering work equipment	●	
Pattern change valve (2 patterns)		●
Fine Swing Control System		●
Tool kit		●
UNDERCARRIAGE		
Lower frame under cover (Additional)		●
Lower frame under cover (Normal)	●	
Track shoes		
Triple grousers shoes (600mm, 24")	●	
Triple grousers shoe (700 mm, 28")		●
Triple grousers shoe (800 mm, 32")		●
Triple grousers shoe (900 mm, 36")		●
Track rail guard	●	

* Standard and optional equipment may vary. Contact your Hyundai dealer for more information.
 The machine may vary according to International standards.
 * The photos may include attachments and optional equipment that are not available in your area.
 * Materials and specifications are subject to change without advance notice.
 * All imperial measurements rounded off to the nearest pound or inch.

HYUNDAI CONSTRUCTION EQUIPMENT
 HEAVY INDUSTRIES

Head Office (Sales Office)
 18TH FL., DIGITAL CUBE BLDG. 34, SANGAMSAN-RO, MAPO-GU, SEOUL 121-904, KOREA
 TEL: (82) (2) 6424-1118 FAX: (82) (2) 6424-1129

Americas Operation : Hyundai Construction Equipment Americas, Inc.
 6100 ATLANTIC BOULEVARD NORCROSS GA 30071 U.S.A TEL: (1) 847-678-823-7802 FAX: (1) 847-678-823-7778

Europe Operation : Hyundai Heavy Industries Europe N.V.
 VOSSENDAAL 11, 2440 GEEL, BELGIUM TEL: (32) 14-56-2200 FAX: (32) 14-59-3405



PLEASE CONTACT

www.hyundai-ce.com

2016. 2 Rev.0

MOVING YOU FURTHER

HX235LCR

With Tier4 final / Stage IV Engine installed



*Photo may include optional equipment.

Net Power

SAE J1349 / 179 HP (133 kW) at 1,950 rpm

Gross Power

SAE J1995 / 190 HP (142 kW) at 1,950 rpm

Travel Speed

5.8 km/hr (3.60 mph) / 3.4 km/hr (2.11 mph)

Operating Weight

25,600 kg / 56,440 lb





RULE THE GROUND

The HX Series excavators are products of HHI's spirit of initiative, creativity, and strong drive. HHI's engineers, who are the best in the industry, have worked tirelessly to offer a zero-defect product. The new HX Series reflects customers' needs in the field gleaned by thorough monitoring. They maximize fuel efficiency and performance proven by rigorous field tests and quality control.



Photo may include optional equipment.

RULE THE GROUND

HX235_{LCR}

The HX series exceeds customer's expectation!
Become a true leader on the ground with HHI's HX series.



WORK MAX, WORTH MAX

- ECO Gauge
- IPC (Intelligent Power Control)
- New Variable Power Control
- Electronic Viscous Fan Clutch
- Attachment Flow Control (Option)
- New Cooling System with Increased Air Flow
- Enlarged Air Inlet with Grill Cover
- One Pedal Straight Travel (Option)
- Cycle Time Improvement



MORE RELIABLE, MORE SUSTAINABLE

- Durable Cooling Module
- Reinforced Pin, Bush, and Polymer Shim
- Reinforced Durability of Upper and Lower Structure and Attachments
- Wear Resistant Cover Plate
- Hi-grade (High-pressure) Hoses



INFOTAINMENT FRONTIER

- Intelligent and Wide Cluster
- Operating Simulation for Joy & Achievement
- Wi-Fi Direct with Smart Phone (Miracast)
- Proportional Auxiliary Hydraulic System
- New Audio System



MODERN COMFORT, SIMPLE AND SAFE SOLUTION

- Easy Access to DEF/AdBlue® Supply System
- Hi-mate (Remote Management System) (Option)
- Viscous Suspension Mount
- Swing Lock System (Option)
- Fine Swing Control (Option)



*Photo may include optional equipment.



UP to 10%
More fuel-efficient
in leveling
(Compared to 9 Series)

90%
Reduction in PM & NOx
(Compared to 9 Series)



*Photo may include optional equipment.

WORK MAX, WORTH MAX

Fuel Efficient System, Allows Great Performance

The HX Series has an eco-friendly, high-performance engine which ensures both excellent fuel efficiency and high power. With outstanding operating performance proven by rigorous tests at various work sites, it will satisfy any customer's needs.



ECO Gauge

Eco Gauge enable economic operation of machines. The gauge level and color displays engine torque and fuel efficiency level. On top of that, the status of fuel consumption such as average rate and the total amount of fuel consumed are displayed. Hourly and daily based fuel consumption can be checked in the detailed menu as well.



IPC (Intelligent Power Control)

The IPC controls Power depending on work environments. Its mode can be selected and released on the monitor. On the excavation mode, pump flow can be easily controlled by a lever, reducing fuel consumption.



Attachment Flow Control (Option)

The HX Series improves pump flow rate by independent control of two pumps. It optimizes attachments for effective flow rate setting depending on attachments (ten breaker types and ten crusher types), enabling various operations matching the site environments.

New Variable Power Control

The HX Series minimizes equipment input and output control signals to improve fuel efficiency. Its three-stage Power mode ensures the highest performance in any operating environment.

- * P(power) mode: Maximizes speed and power of the equipment for heavy load work.
- * S(standard) mode: Optimizes performance and fuel efficiency of the equipment for general load work.
- * E(economy) mode: Improves the control system for light load work.

Electronic Viscous Fan Clutch

The electronic fan clutch reduces noise during operation by precisely controlling RPM depending on the hydraulic oil and coolant temperature of the working vehicle, and minimizes fuel consumption. It is also possible to shorten the warm up time of hydraulic oil.

Enlarged Air Inlet with Grill Cover

Enlarged vent hole of the air inlet side cover and fine net grill to prevent penetration of foreign materials further improve durability.

MORE RELIABLE, MORE SUSTAINABLE

New Exterior Design for Robustness and Safety

The true value of the HX Series lies in its durability. The robust upper and lower frame structure that can endure external shock and high-load work and the attachments whose performance was proven by rigorous tests further show the real value of the HX Series in tough working environments and promise higher productivity.



Durable Cooling Module

The HX Series has a durable cooling module that passed stringent tests, demonstrating the highest productivity in tough working environments.



Chrome Coated Pins

Reinforced Pin, Bush, and Polymer Shim

The HX series improves lubricity of connecting parts between the equipment and attachments. Gaps with attachments are minimized by wear-resistant long-life pins, bushes, and polymer shims, supporting the highest performance with invariable durability.

Wear Resistant Cover Plate

A wear-resistant cover plate is installed at the end of the arm to minimize abrasion on the connector between the arm and the bucket. Reduction of vibration of the buckets enables more stable operation even in high-load work.



Reinforced Durability of Upper and Lower Structure and Attachments

The upper and lower structure and attachments of the HX Series have higher durability than demanded on the site, as proven through numerous tests including road tests and virtual simulation. The wear resistance of the bucket has been improved by use of new material.



*Photo may include optional equipment.

Hi-grade (High-pressure) Hoses

The HX Series uses high-pressure hoses with improved heat and pressure resistance, greatly increasing the durability of the equipment.



New Air Conditioning System

With further improved air conditioning and heating, the HX Series increases the APTC capacity by 15% to provide a pleasant environment for operators all the time. The ventilation was designed such that warm and cool air even reach operators' faces (increasing their work satisfaction) or allowing pleasant working environment.

INFOTAINMENT FRONTIER

Enhanced Instrument Panel for Easier Monitoring

Many electronic functions are concentrated on the most convenient spot for operators to ensure work efficiency. The highly-advanced infotainment system, a product of HHI's intensive information technology, enables both productivity and pleasant work at the same time! The HX Series of HHI provides higher value and pleasure to customers.



Intelligent and Wide Cluster

The 8-inch capacitive-type display (like smartphone display) of the HX Series is 15% larger than the previous model, delivering excellent legibility. The centralized switches on the display allow convenience of checking the urea level and temperature outside the cabin. The audio AUX, air conditioner, heater interoperation, wiper, lamp, overload warning, travel, alarm and inclination sensor also maximize operator's convenience.

Wi-Fi Direct with Smart Phone (Miracast)

The Miracast system based on Wi-Fi of the operator's smart phone enables easy and convenient use of various features of the smart phone on the big screen including navigation, web surfing, viewing of videos, and listening to music. (For Android mobile phone now)



New Audio System

Radio player, USB-based MP3 player, integrated Bluetooth hands-free feature, and built-in microphone allow convenient phone calls while in work and in transit. The radio player was moved to the right side from the rear, allowing easier access.

Proportional Auxiliary Hydraulic System

- Opt: Proportional control switch for better speed control
- Enlarge the operation convenience

MODERN COMFORT, SIMPLE AND SAFE SOLUTION

New Cabin for More Comfort

Low noise, low vibration, and ergonomic design make the cabin space more comfortable and pleasant! With focus on safety and convenience of operators, the HX Series allows rapid and safe equipment inspection anytime and anywhere, providing an optimal environment for operators to work.



Easy Access to DEF/AdBlue® Supply System

The DEF/AdBlue® tank is installed inside the tool box and its inlet is remotely located for easy access and convenient supply. Warning of overfill is given by a red lamp signal. The DEF/AdBlue® supply module is attached on the side of the hydraulic tank for easy maintenance and filter replacement.



Hi-mate (Remote Management System) (Option)

Hi-mate, Hyundai's proprietary remote management system, provides operators and dealer service personnel access to vital service and diagnostic information on the machine from any computer with internet access. Users can pinpoint machine location using digital mapping and set machine work boundaries, reducing the need for multiple service calls. Hi-mate saves time and money for the owner and dealer by promoting preventative maintenance and reducing machine downtime.

* Operation of the system may be affected by the condition of telecommunication signal



*Photo may include optional equipment

Swing Lock System (Option)

Swing Lock System is provided to maintain stability when swing movement needs to be limited, improving operating speed and productivity.

Fine Swing Control (Option)

Fine swing control is available for customer's convenience when users want to control fine swing.





SPECIFICATIONS

ENGINE		
Maker / Model	CUMMINS QSB6.7 Engine	
Type	Water cooled, 4 cycle Diesel, 6-cylinders in line, direct injection, turbocharged charger and air cooled	
Rated flywheel horse power	SAE J1995 (gross)	183HP (136kW)/ 1,950 rpm
	J1349 (net)	173HP (129kW)/ 1,950 rpm
DIN	6271/1 (gross)	185PS (136kW)/ 1,950 rpm
	6271/1 (net)	175PS (129kW)/ 1,950 rpm
Max. torque	85.7kgf.m (620lbf.ft)/1,500rpm	
Bore X stroke	107mm X 124mm (4.2" X 4.9")	
Piston displacement	6,700cc (409 in ³)	
Batteries	2 X 12V X 100AH	
Starting motor	24V, 4.8kW	
Alternator	24V, 95Amp	

HYDRAULIC SYSTEM	
MAIN PUMP	
Type	Variable displacement tandem axis piston pumps
Max. flow	2 X 228.2 L /min (60.3 US gpm/50.2 UK gpm)
Sub-pump for pilot circuit	Gear pump
Cross-sensing and fuel saving pump system	
HYDRAULIC MOTORS	
Travel	Two speed axial pistons motor with brake valve and parking brake
Swing	Axial piston motor with automatic brake
RELIEF VALVE SETTING	
Implement circuits	350 kgf/cm ² (4,980 psi)
Travel	350 kgf/cm ² (4,980 psi)
Power boost (boom, arm, bucket)	380 kgf/cm ² (5,410 psi)
Swing circuit	285 kgf/cm ² (4,050 psi)
Pilot circuit	40 kgf/cm ² (570 psi)
Service valve	Installed
HYDRAULIC CYLINDERS	
No. of cylinder bore X stroke	Boom: 2-125 X 1,260 mm ()
	Arm: 1-160 X 1,610 mm ()
	Bucket: 1-120 X 1,055 mm (4.7" X 41.5")
	Blade: 2-130 X 240 mm ()
2-Piece Boom	1st: 2-105 X 995 mm (4.1" X 39.2")
	2nd: 1-145 X 613 mm (5.7" X 24.1")
DRIVES & BRAKES	
Drive method	Fully hydrostatic type
Drive motor	Axial piston motor, in-shoe design
Reduction system	Planetary reduction gear
Max. drawbar pull	20,600kgf (45,415 lbf)
Max. travel speed (high / low)	5.5 km/hr (3.5mph) / 3.3 km/hr (2.1mph)
Gradeability	35° (70 %)
Parking brake	Multi wet disc

CONTROL			
Pilot pressure operated joysticks and pedals with detachable lever provide almost effortless and fatigueless operation.			
Pilot control	Two joysticks with one safety lever (LH): Swing and arm, (RH): Boom and bucket(ISO)		
Traveling and steering	Two levers with pedals		
Engine throttle	Electric, Dial type		
SWING SYSTEM			
Swing motor	Fixed displacement axial piston motor		
Swing reduction	Planetary gear reduction		
Swing bearing lubrication	Grease-bathed		
Swing brake	Multi wet disc		
Swing speed	10.8 rpm		
SERVICE REFILL CAPACITIES			
Re-filling	liter	US gal	UK gal
Fuel tank	320	84.5	70.4
Engine coolant	40	10.6	8.8
Engine oil	23.7	6.3	5.2
Swing device	7	1.8	1.5
Final drive (each)	4.5	1.2	1.0
DEF / AdBlue R tank	27	7.1	5.9
Hydraulic system (including tank)	275	72.6	60.5
Hydraulic tank	160	42.3	35.2
UNDERCARRIAGE			
The X-leg type center frame is integrally welded with reinforced box-section track frames. The undercarriage includes lubricated rollers, idlers, track adjusters with shock absorbing springs and sprockets, and a track chain with double or triple grouser shoes.			
Center frame	X - leg type		
Track frame	Pentagonal box type		
No. of shoes on each side	49 EA		
No. of carrier roller on each side	2 EA		
No. of track roller on each side	9 EA		
No. of rail guard on each side	2 EA		
OPERATING WEIGHT (APPROXIMATE)			
Operating weight, including 5,680mm (18' 8") boom, 2,920mm (9' 7") arm, SAE heaped 0.80m ³ (1.05 yd ³) bucket, lubricant, coolant, full fuel tank, full hydraulic tank, and all standard equipments.			
OPERATING WEIGHT			
Shoes	Operating weight	Ground pressure	
Type	Width mm (in)	kg (lb)	kgf/cm ² (psi)
Triple grouser	600 (24")	24,000 (52,910)	0.51 (7.25)
	700 (28")	24,280 (53,530)	0.44 (6.26)
	800 (32")	24,560 (54,140)	0.39 (5.55)
	900 (36")	24,840 (54,760)	0.35 (4.98)

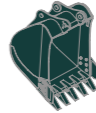
BUCKET SELECTION GUIDE & DIGGING FORCE

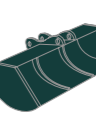
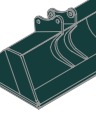
BUCKETS										
All buckets are welded with high-strength steel.										
										
SAE heaped m ³ (yd ³)	0.51 (0.67)	0.80 (1.05)	1.10 (1.44)	1.34 (1.75)	◆ 0.74 (0.97) ◆ 0.90 (1.18) ◆ 1.05 (1.37)	● 0.87 (1.14)	■ 0.75 (0.98)			
		0.87 (1.14) 0.92 (1.20)	1.20 (1.57)							
Capacity m ³ (yd ³)		Width mm (in)		Weight kg (lb)	Recommendation mm (ft.in)					
SAE heaped	CECE heaped	Without side cutters	With side cutters		5,680 (18' 8") Mono Boom			5,650 (18'6") 2-Piece Boom		
					2,000 (6' 7") Arm	2,400 (7' 10") Arm	2,920 (9' 7") Arm	2,000 (6' 7") Arm	2,400 (7' 10") Arm	2,920 (9' 7") Arm
0.51 (0.67)	0.45 (0.59)	700 (27.6)	820 (32.3)	570 (1,260)	●	●	●	●	●	●
0.80 (1.05)	0.70 (0.92)	1,000 (39.4)	1,120 (44.1)	700 (1,540)	●	●	●	●	●	■
0.87 (1.14)	0.75 (0.98)	1,090 (42.9)	1,210 (47.6)	740 (1,630)	●	●	■	●	●	■
0.92 (1.20)	0.80 (1.05)	1,150 (45.3)	1,270 (50.0)	770 (1,700)	●	●	■	●	●	▲
1.10 (1.44)	0.96 (1.26)	1,320 (52.0)	1,440 (56.7)	830 (1,830)	●	■	▲	■	■	▲
1.20 (1.57)	1.00 (1.31)	1,400 (55.1)	1,520 (59.8)	850 (1,870)	■	▲	-	■	▲	-
1.34 (1.75)	1.15 (1.50)	1,550 (61.0)	1,670 (65.7)	920 (2,030)	▲	▲	-	▲	-	-
◆ 0.74 (0.97)	0.65 (0.85)	985 (38.8)	-	770 (1,700)	●	●	●	●	●	■
◆ 0.90 (1.18)	0.80 (1.05)	1,095 (43.1)	-	810 (1,790)	●	●	■	●	●	▲
◆ 1.05 (1.37)	0.92 (1.20)	1,290 (50.8)	-	890 (1,960)	●	■	▲	■	■	▲
● 0.87 (1.14)	0.75 (0.98)	1,140 (44.9)	-	900 (1,980)	●	●	■	●	●	▲
■ 0.75 (0.98)	0.65 (0.85)	1,790 (70.5)	-	880 (1,940)	●	●	■	●	●	▲
					● : Applicable for materials with density of 2,000 kgf/m ³ (3,370 lbf/yd ³) or less ■ : Applicable for materials with density of 1,600 kgf/m ³ (2,700 lbf/yd ³) or less ▲ : Applicable for materials with density of 1,100 kgf/m ³ (1,850 lbf/yd ³) or less					
					◆ Heavy duty bucket ● Rock-Heavy duty bucket ■ Slope finishing bucket					
ATTACHMENT										
Booms and arms are welded with a low-stress, full-box section design. 5.68m (18'8") Mono, 5.65m (18'6") 2 Piece Booms and 2.0m (6'7"), 2.4m (7'10"), 2.92m (9'7") Arms are available.										
DIGGING FORCE										
Arm	Length	mm (ft.in)	2,000 (6' 7")		2,400 (7' 10")		2,920 (9' 7")		Remark	
	Weight	kg (lb)	975 (2,150)		1,045 (2,300)		1,095 (2,410)			
Bucket digging force	SAE	kN	133.4 [144.8]		133.4 [144.8]		133.4 [144.8]		[]: Power Boost	
		kgf	13600 [14770]		13600 [14770]		13600 [14770]			
		lbf	29980 [32550]		29980 [32550]		29980 [32550]			
	ISO	kN	152.0 [165.0]		152.0 [165.0]		152.0 [165.0]			
		kgf	15500 [16830]		15500 [16830]		15500 [16830]			
		lbf	34170 [37100]		34170 [37100]		34170 [37100]			
Arm crowd force	SAE	kN	144.2 [156.5]		119.6 [129.9]		102.0 [110.7]			
		kgf	14700 [15960]		12200 [13250]		10400 [11290]			
		lbf	32410 [35190]		26900 [29210]		22930 [24900]			
	ISO	kN	151.0 [164.0]		125.5 [136.3]		106.9 [116.1]			
		kgf	15400 [16720]		12800 [13900]		10900 [11830]			
		lbf	33950 [36860]		28220 [30640]		24030 [26090]			

Note: Arm weight includes bucket cylinder, linkage, and pin

DIMENSIONS & WORKING RANGE

HX235LCR MONO BOOM DIMENSIONS

5.68 m (18' 8") BOOM and 2.0 m (6' 7"), 2.4 m (7' 10"), 2.92 m (9' 7") ARM

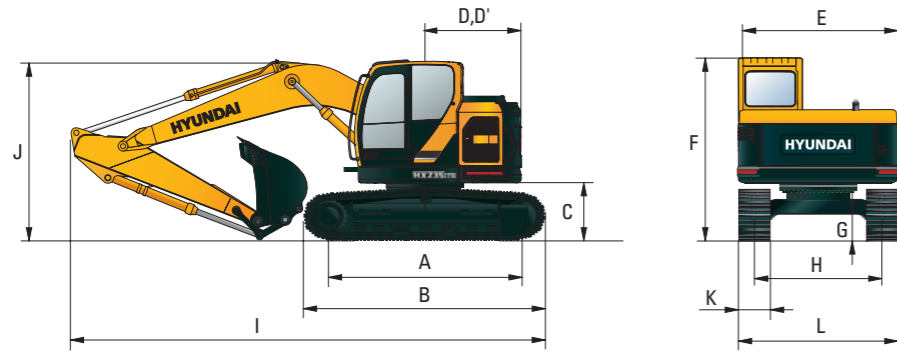

Unit : mm (ft - in)

A	Tumbler distance	3,650 (12' 0")
B	Overall length of crawler	4,404 (14' 6")
C	Ground clearance of counterweight	1,080 (3' 7")
D	Tail swing radius	1,780 (6' 04")
D'	Rear-end length	1,780 (6' 04")
E	Overall width of upperstructure	2,980 (9' 9")
F	Overall height of cab	3,290 (10' 10")
G	Min. ground clearance	480 (1' 7")
H	Track gauge	2,390 (7' 10")

Boom length	5,680 (18' 8")			
Arm length	2,000 (6' 7")	2,400 (7' 10")	2,920 (9' 7")	
I	9,040 (29' 8")	8,950 (29' 4")	8,910 (29' 3")	
J	3,200 (10' 6")	3,100 (10' 2")	3,020 (9' 11")	
K	600 (24")	700 (28")	800 (32")	900 (36")
L	2,990 (9' 10")	3,090 (10' 2")	3,190 (10' 6")	3,290 (10' 10")

HX235LCR MONO BOOM WORKING RANGE

Unit : mm (ft - in)

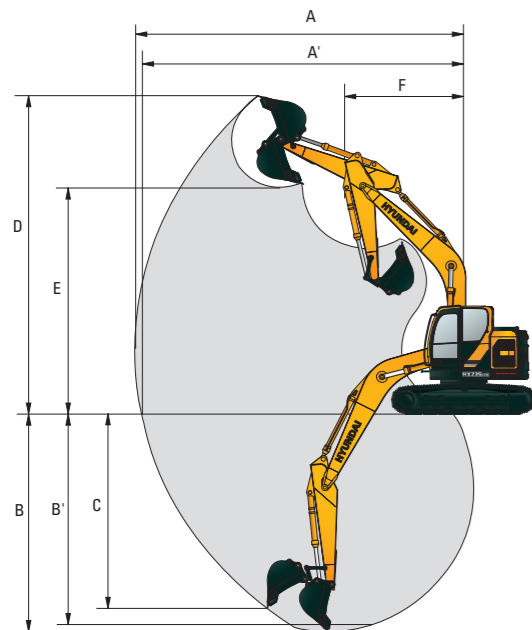

Boom length	5,680 (18' 8")		
Arm length	2,000 (6' 7")	2,400 (7' 10")	2,920 (9' 7")
A	9,040 (29' 8")	9,430 (30' 11")	9,910 (32' 6")
A'	8,860 (29' 1")	9,260 (30' 5")	9,750 (32' 0")
B	5,780 (19' 0")	6,180 (20' 3")	6,700 (22' 0")
B'	5,550 (19' 0")	5,980 (19' 7")	6,530 (21' 5")
C	5,140 (16' 10")	5,710 (18' 9")	6,270 (20' 7")
D	10,090 (33' 1")	10,420 (34' 2")	10,830 (35' 6")
E	7,190 (23' 7")	7,510 (24' 8")	7,890 (25' 11")
F	2,860 (9' 5")	2,550 (8' 4")	2,350 (7' 9")

HX235LCR MONO BOOM (DOZER TYPE) DIMENSIONS

5.68 m (18' 8") BOOM and 2.0 m (6' 7"), 2.4 m (7' 10"), 2.92 m (9' 7") ARM

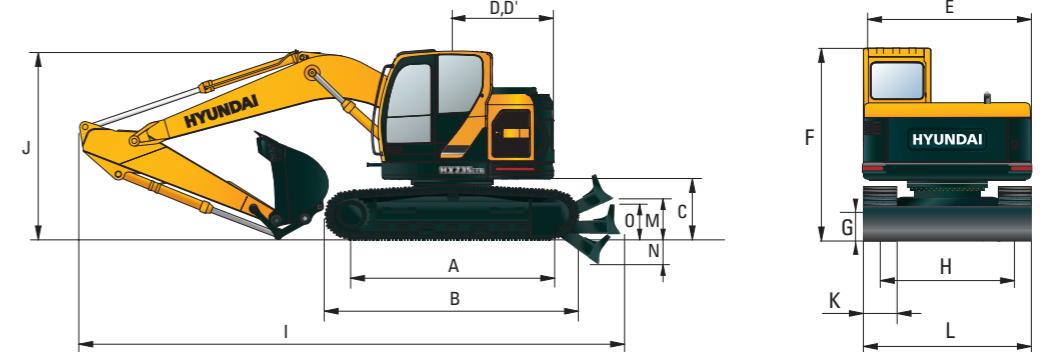

Unit : mm (ft - in)

A	Tumbler distance	3,650 (12' 0")
B	Overall length of crawler	4,404 (14' 6")
C	Ground clearance of counterweight	1,080 (3' 7")
D	Tail swing radius	1,780 (6' 04")
D'	Rear-end length	1,780 (6' 04")
E	Overall width of upperstructure	2,980 (9' 9")
F	Overall height of cab	3,290 (10' 10")
G	Min. ground clearance	480 (1' 7")
H	Track gauge	2,390 (7' 10")
M	Ground clearance of blade up	550 (1' 10")
N	Depth of blade down	410 (1' 4")
O	Height of blade	740 (2' 5")

Boom length	5,680 (18' 8")			
Arm length	2,000 (6' 7")	2,400 (7' 10")	2,920 (9' 7")	
I	10,020 (32' 10")	9,930 (32' 7")	9,890 (32' 5")	
J	3,200 (10' 6")	3,100 (10' 2")	3,020 (9' 11")	
K	600 (24")	700 (28")	800 (32")	900 (36")
L	2,990 (9' 10")	3,090 (10' 2")	3,190 (10' 6")	3,290 (10' 10")

HX235LCR MONO BOOM (DOZER TYPE) WORKING RANGE

Unit : mm (ft - in)

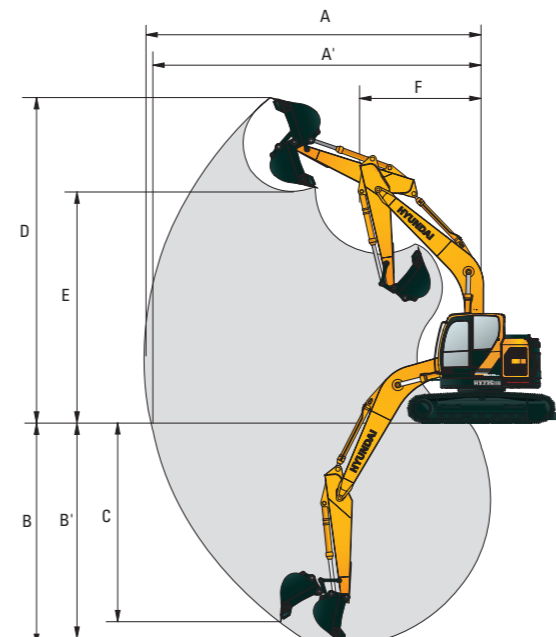

Boom length	5,680 (18' 8")		
Arm length	2,000 (6' 7")	2,400 (7' 10")	2,920 (9' 7")
A	9,040 (29' 8")	9,430 (30' 11")	9,910 (32' 6")
A'	8,860 (29' 1")	9,260 (30' 5")	9,750 (32' 0")
B	5,780 (19' 0")	6,180 (20' 3")	6,700 (22' 0")
B'	5,550 (18' 3")	5,980 (19' 7")	6,530 (21' 5")
C	5,140 (16' 10")	5,710 (18' 9")	6,270 (20' 7")
D	10,090 (33' 1")	10,420 (34' 2")	10,830 (35' 6")
E	7,190 (23' 7")	7,510 (24' 8")	7,890 (25' 11")
F	2,860 (9' 5")	2,550 (8' 4")	2,350 (7' 9")

DIMENSIONS & WORKING RANGE

HX235LCR 2-PIECE BOOM DIMENSIONS

5.65 m (18' 6") 2-Piece Boom and 2.0 m (6' 7"), 2.4 m (7' 10"), 2.92 m (9' 7") Arm

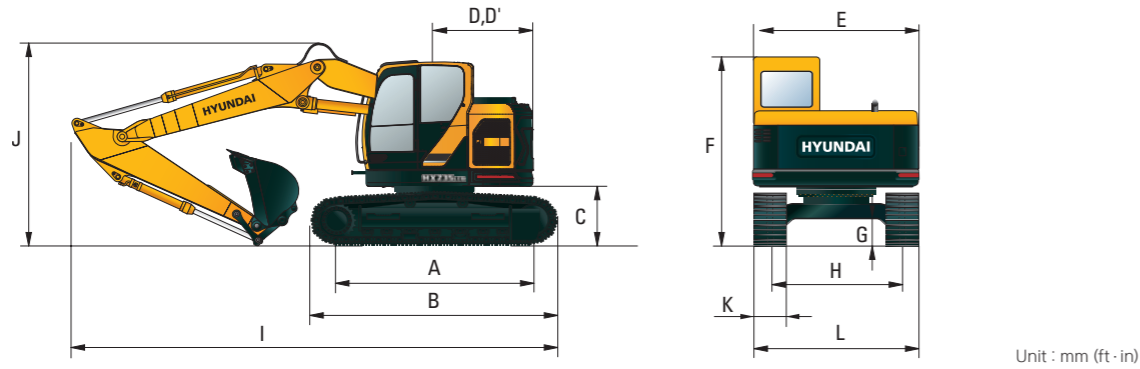

A	Tumbler distance	3,650 (12' 0")
B	Overall length of crawler	4,404 (14' 6")
C	Ground clearance of counterweight	1,080 (3' 7")
D	Tail swing radius	1,780 (6' 04")
D'	Rear-end length	1,780 (6' 04")
E	Overall width of upperstructure	2,980 (9' 9")
F	Overall height of cab	3,290 (10' 10")
G	Min. ground clearance	480 (1' 7")
H	Track gauge	2,390 (7' 10")

Boom length	5,650 (18' 6") 2-Piece			
Arm length	2,000 (6' 7")	2,400 (7' 10")	2,920 (9' 7")	
I	9,000 (29' 6")	8,910 (29' 3")	8,900 (29' 2")	
J	3,050 (10' 0")	3,000 (9' 10")	2,990 (9' 10")	
L	600 (24")	700 (28")	800 (32")	900 (36")
M	2,990 (9' 10")	3,090 (10' 2")	3,190 (10' 6")	3,290 (10' 10")

HX235LCR 2-PIECE BOOM WORKING RANGE

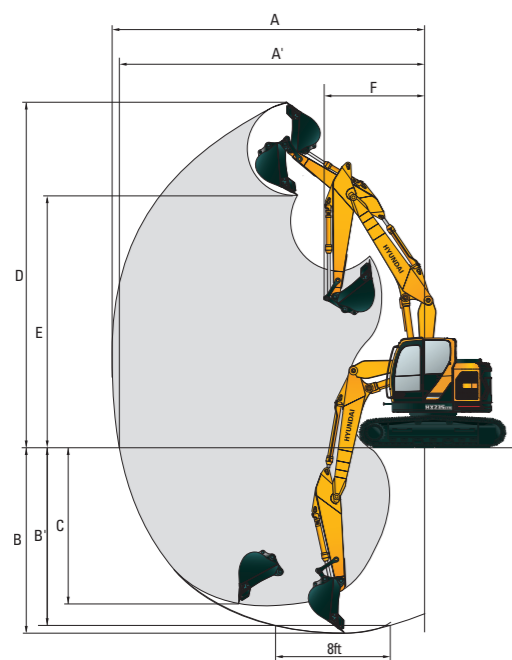

Boom length	5,650 (18' 6") 2-Piece			
Arm length	2,000 (6' 7")	2,400 (7' 10")	2,920 (9' 7")	
A	9,050 (29' 8")	9,460 (31' 0")	10,020 (32' 10")	
A'	8,880 (29' 2")	9,290 (30' 6")	9,860 (32' 4")	
B	5,460 (17' 11")	5,860 (19' 3")	6,380 (20' 11")	
B'	5,340 (17' 6")	5,750 (18' 10")	6,270 (20' 7")	
C	4,530 (14' 10")	4,970 (16' 4")	5,520 (18' 1")	
D	10,600 (34' 9")	10,990 (36' 1")	11,470 (37' 8")	
E	7,680 (25' 2")	8,090 (26' 7")	8,540 (28' 0")	
F	2,130 (7' 0")	2,030 (6' 8")	2,000 (6' 7")	

HX235LCR 2-PIECE BOOM (DOZER TYPE) DIMENSIONS

5.65 m (18' 6") 2-Piece Boom and 2.0 m (6' 7"), 2.4 m (7' 10"), 2.92 m (9' 7") Arm

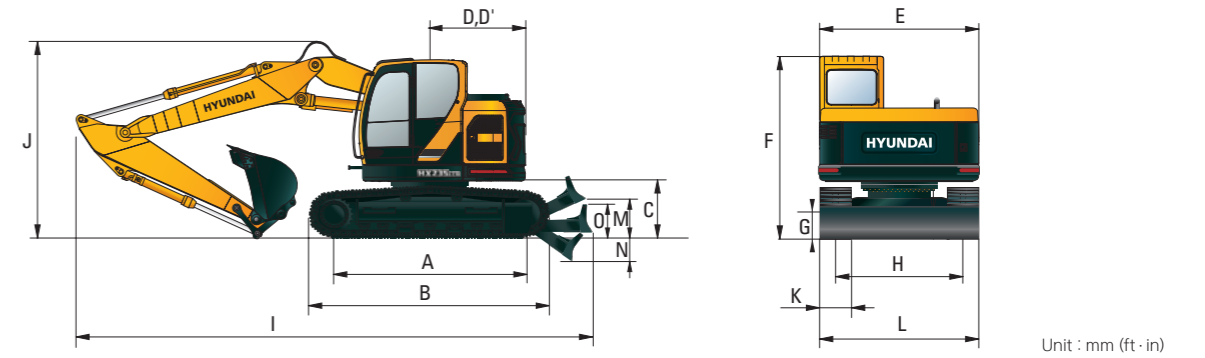

A	Tumbler distance	3,650 (12' 0")
B	Overall length of crawler	4,404 (14' 6")
C	Ground clearance of counterweight	1,080 (3' 7")
D	Tail swing radius	1,780 (6' 04")
D'	Rear-end length	1,780 (6' 04")
E	Overall width of upperstructure	2,980 (9' 9")
F	Overall height of cab	3,290 (10' 10")
G	Min. ground clearance	480 (1' 7")
H	Track gauge	2,390 (7' 10")
M	Ground clearance of blade up	550 (1' 10")
N	Depth of blade down	410 (1' 4")
O	Height of blade	740 (2' 5")

Boom length	5,650 (18' 6") 2-Piece			
Arm length	2,000 (6' 7")	2,400 (7' 10")	2,920 (9' 7")	
I	9,850 (32' 4")	9,760 (32' 0")	9,750 (32' 0")	
J	3,050 (10' 0")	3,000 (9' 10")	2,990 (9' 10")	
K	600 (24")	700 (28")	800 (32")	900 (36")
L	2,990 (9' 10")	3,090 (10' 2")	3,190 (10' 6")	3,290 (10' 10")

HX235LCR 2-PIECE BOOM (DOZER TYPE) WORKING RANGE

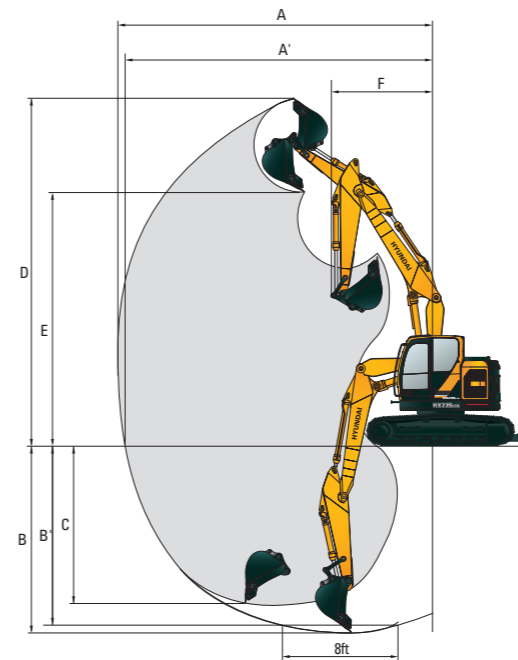











Boom length	5,650 (18' 6") 2-Piece			
Arm length	2,000 (6' 7")	2,400 (7' 10")	2,920 (9' 7")	
A	9,050 (29' 8")	9,460 (31' 0")	10,020 (32' 10")	
A'	8,880 (29' 2")	9,290 (30' 6")	9,860 (32' 4")	
B	5,460 (17' 11")	5,860 (19' 3")	6,380 (20' 11")	
B'	5,340 (17' 6")	5,750 (18' 10")	6,270 (20' 7")	
C	4,530 (14' 10")	4,970 (16' 4")	5,520 (18' 1")	
D	10,600 (34' 9")	10,990 (36' 1")	11,470 (37' 8")	
E	7,680 (25' 2")	8,090 (26' 7")	8,540 (28' 0")	
F	2,130 (7' 0")	2,030 (6' 8")	2,000 (6' 7")	

LIFTING CAPACITY











 Rating over-front  Rating over-side or 360 degree

HX235LCR 2-PIECE BOOM

Boom: 5.65 m (18' 6") / Arm: 2.40 m (7' 10") / Bucket: 0.80 m³ (1.05 yd³) SAE heaped / Shoe: 600mm(24") triple grouser

Load point height m (ft)	Load radius								At max. reach		
	3.0 m (10 ft)		4.5 m (15 ft)		6.0 m (20 ft)		7.5 m (25 ft)		Capacity	Reach	
											m (ft)
9.0 m (30 ft)	kg *5600	kg *5600							*5830	*5830	5.31
	lb *12350	lb *12350							*12850	*12850	(17.4)
7.5 m (25 ft)	kg *6240	kg *6240	*5830	*5830					*4760	3880	7.10
	lb *13760	lb *13760	*12850	*12850					*10490	8550	(23.3)
6.0 m (20 ft)	kg *6390	kg *6390	*6570	*6570	*5480	5140			*4290	2950	8.15
	lb *14090	lb *14090	*14480	*14480	*12080	11330			*9460	6500	(26.7)
4.5 m (15 ft)	kg *10370	kg *10370	*7270	*7270	*5720	4960	*4040	3310	*3980	2500	8.77
	lb *22860	lb *22860	*16030	*16030	*12610	10930	*8910	7300	*8770	5510	(28.8)
3.0 m (10 ft)	kg *8170	kg 7380	*6050	4670	*4790	3200	*3720	2290	*3720	2290	9.06
	lb *18010	lb 16270	*13340	10300	*10560	7050	*8200	5050	*8200	5050	(29.7)
1.5 m (5 ft)	kg *8620	kg 6770	*6220	4380	*4740	3060	*3420	2240	*3420	2240	9.06
	lb *19000	lb 14930	*13710	9660	*10450	6750	*7540	4940	*7540	4940	(29.7)
Ground Line	kg *8940	kg *8940	*8190	6450	*5980	4180	*4400	2960	*3010	2350	8.77
	lb *19710	lb *19710	*18060	14220	*13180	9220	*9700	6530	*6640	5180	(28.8)
-1.5 m (-5 ft)	kg *8500	kg *8500	*6940	6370	*5160	4110			*2360	*2360	8.15
	lb *18740	lb *18740	*15300	14040	*11380	9060			*5200	*5200	(26.7)
-3.0 m (-10 ft)	kg *4860	kg *4860	*3490	*3490							
	lb *10710	lb *10710	*7690	*7690							

Boom: 5.65 m (18' 6") / Arm: 2.92 m (9' 7") / Bucket: 0.80 m³ (1.05 yd³) SAE heaped / Shoe: 600mm(24") triple grouser











Load point height m (ft)	Load radius								At max. reach		
	3.0 m (10 ft)		4.5 m (15 ft)		6.0 m (20 ft)		7.5 m (25 ft)		Capacity	Reach	
											m (ft)
9.0 m (30 ft)	kg *4950	kg *4950	*3120	*3120					*4630	*4630	6.19
	lb *10910	lb *10910	*6880	*6880					*10210	*10210	(20.3)
7.5 m (25 ft)	kg *4750	kg *4750	*3400	*3400					*4050	3560	7.75
	lb *10470	lb *10470	*7500	*7500					*8930	7850	(25.4)
6.0 m (20 ft)	kg *4760	kg *4760	*5190	*5190	*4840	*4840	*2180	*2180	*3820	2800	8.71
	lb *10490	lb *10490	*11440	*11440	*10670	*10670	*4810	*4810	*8420	6170	(28.6)
4.5 m (15 ft)	kg *6690	kg *6690	*6760	*6760	*5420	5370	*4250	3600	*3650	2410	9.29
	lb *14750	lb *14750	*14900	*14900	*11950	11840	*9370	7640	*8050	5310	(30.5)
3.0 m (10 ft)	kg *12100	kg *12100	*7760	*7760	*5820	5060	*4670	3450	*3430	2220	9.56
	lb *26680	lb *26680	*17110	*17110	*12830	11160	*10300	7610	*7560	4890	(31.4)
1.5 m (5 ft)	kg *9380	kg *9380	*8470	7400	*6110	4730	*4710	3290	*3180	2180	9.56
	lb *20680	lb *20680	*18670	16310	*13470	10430	*10380	7250	*7010	4810	(31.4)
Ground Line	kg *9730	kg *9730	*8370	6970	*6040	4480	*4520	3160	*2850	2270	9.29
	lb *21450	lb *21450	*18450	15370	*13320	9880	*9960	6970	*6280	5000	(30.5)
-1.5 m (-5 ft)	kg *9980	kg *9980	*7420	6810	*5440	4360	*3890	3100	*2330	*2330	8.71
	lb *22000	lb *22000	*16360	15010	*11990	9610	*8580	6830	*5140	*5140	(28.6)
-3.0 m (-10 ft)	kg *7060	kg *7060	*5650	*5650	*4130	*4130					
	lb *15560	lb *15560	*12460	*12460	*9110	*9110					

- Lifting capacity are based on SAE J1097 and ISO 10567.
- Lifting capacity of the ROBEX series does not exceed 75% of tipping load with the machine on firm, level ground or 87% of full hydraulic capacity.
- The load point is a hook (standard equipment) located on the back of the bucket.
- (*) indicates load limited by hydraulic capacity.

 Rating over-front  Rating over-side or 360 degree

HX235LCR 2-PIECE BOOM

Boom: 5.65 m (18' 6") / Arm: 2.92 m (9' 7") / Bucket: 0.80 m³ (1.05 yd³) SAE heaped / Shoe: 600mm(24") triple grouser

Load point height m (ft)	Load radius								At max. reach		
	3.0 m (10 ft)		4.5 m (15 ft)		6.0 m (20 ft)		7.5 m (25 ft)		Capacity	Reach	
											m (ft)
9.0 m (30 ft)	kg *4950	kg *4950	*3120	*3120					*4630	*4630	6.19
	lb *10910	lb *10910	*6880	*6880					*10210	*10210	(20.3)
7.5 m (25 ft)	kg *4750	kg *4750	*3400	*3400					*4050	3340	7.75
	lb *10470	lb *10470	*7500	*7500					*8930	7360	(25.4)
6.0 m (20 ft)	kg *4760	kg *4760	*5190	*5190	*4840	*4840	*2180	*2180	*3820	2610	8.71
	lb *10490	lb *10490	*11440	*11440	*10670	*10670	*4810	*4810	*8420	5750	(28.6)
4.5 m (15 ft)	kg *6690	kg *6690	*6760	*6760	*5420	5040	*4250	3360	*3650	2240	9.29
	lb *14750	lb *14750	*14900	*14900	*11950	11110	*9370	7410	*8050	4940	(30.5)
3.0 m (10 ft)	kg *12100	kg *12100	*7760	7560	*5820	4730	*4670	3220	*3430	2060	9.56
	lb *26680	lb *26680	*17110	16670	*12830	10430	*10300	7100	*7560	4540	(31.4)
1.5 m (5 ft)	kg *9380	kg *9380	*8470	6870	*6110	4400	*4710	3060	*3180	2010	9.56
	lb *20680	lb *20680	*18670	15150	*13470	9700	*10380	6750	*7010	4430	(31.4)
Ground Line	kg *9730	kg *9730	*8370	6450	*6040	4160	*4520	2930	*2850	2100	9.29
	lb *21450	lb *21450	*18450	14220	*13320	9170	*9960	6460	*6280	4630	(30.5)
-1.5 m (-5 ft)	kg *9980	kg *9980	*7420	6290	*5440	4040	*3890	2870	*2330	*2330	8.71
	lb *22000	lb *22000	*16360	13870	*11990	8910	*8580	6330	*5140	*5140	(28.6)
-3.0 m (-10 ft)	kg *7060	kg *7060	*5650	*5650	*4130	4050					
	lb *15560	lb *15560	*12460	*12460	*9110	8930					

- Lifting capacity are based on SAE J1097 and ISO 10567.
- Lifting capacity of the ROBEX series does not exceed 75% of tipping load with the machine on firm, level ground or 87% of full hydraulic capacity.
- The load point is a hook (standard equipment) located on the back of the bucket.
- (*) indicates load limited by hydraulic capacity.