

# HYUNDAI

## HX230L SPECIFICATIONS

**Net Power**  
186 hp (139 kW) at 1,700 rpm

**Operating Weight**  
54,900 lb (24,900 kg)

**Standard Bucket**  
1.31 yd<sup>3</sup> (1.05 m<sup>3</sup>)

ENGINE	
Make / Model	HYUNDAI / DX05
Type	4-cycle, turbocharged, charge air-cooled, controlled by ECU
Net Power (SAE J1349)	186 hp (139 kW) at 1,700 rpm
Max. Power (SAE J1995)	189 hp (141 kW) at 1,700 rpm
Max. Torque	704 lb ft (955 Nm) at 1,400 rpm
Displacement	306 in <sup>3</sup> (5018 cc)

ELECTRICAL SYSTEM	
Batteries	2 × 12 V, 150 Ah
Alternator	24 V, 90 A
Starter	24 V, 6.0 kW

HYDRAULIC SYSTEM		
<b>MAIN PUMP</b>		
Type	Cross-sensing and fuel-saving pump system	
Type	Variable-displacement tandem axis piston pumps	
Max. Oil Flow	2 × 62.7 gpm (2 × 237.5 l/min)	
Displacement	2 × 7.6 in <sup>3</sup> /rev (2 × 125 cc/rev)	
Rated Speed	1,900 rpm	
<b>PILOT PUMP</b>		
Type	Fixed-displacement gear pump	
Max. Oil Flow	6.7 gpm (25.5 l/min)	
<b>RELIEF VALVE SETTING</b>		
Maximum Pressure	4,970 psi (343 bar)	
Maximum Pressure (Power boost)	5,410 psi (373 bar)	
<b>HYDRAULIC CYLINDERS</b>		
No. of Cylinders	Boom	5" × 54" (130 × 1,385 mm)
Bore × Stroke	Arm	6" × 65" (145 × 1,655 mm)
	Bucket	5" × 43" (130 × 1,080 mm)

AUXILIARY CIRCUIT	
Operating Flow	13-112 gpm (50-212 l/min)
Operating Pressure	2030-4931 psi (140-340 bar)
<b>ROTATE CIRCUIT (OPTION)</b>	
Operating Flow	13 gpm (52.7 l/min)
Operating Pressure	2320 psi (160 bar)

TRAVEL SYSTEM		
Drive Method	Variable-displacement axial piston motor	
Max. Drawbar Pull	76,941 lbf (34,900 kgf/cm <sup>2</sup> )	
Travel Speed	High	3.2 mph (5.2 km/h)
	Low	1.9 mph (3.0 km/h)
Gradeability	70% (35°)	

CONTROL	
Electronic joysticks and pedals provide almost effortless and fatigue-less operation.	
FEH-EPOS control	Two joysticks with one safety lever (LH): Swing and arm, (RH): Boom and bucket
Traveling and Steering	Two levers with pedals, two levers
Engine Throttle	Electric, dial type—12 setting levels

SWING SYSTEM	
Swing Motor	Fixed displacement axial piston motor
Swing Reduction	2-stage planetary reduction gear
Swing Brake	Solenoid, hydraulic
Swing Speed	10.4 rpm
Swing Torque	59,004 lb ft (80 kNm)

DIGGING FORCE				
Arm Length		9' 6" (2,900 mm)	11' 6" (3,500 mm)	
Arm Crowd Force	SAE	lbf	23,160 [25,140]	20,730 [22,490]
		kN	103 [112]	92 [100]
	ISO	lbf	23,820 [25800]	21,390 [23,160]
		kN	106 [115]	95 [103]
Bucket Breakout Force	SAE	lbf	29,230 [31,720]	
		kN	130 [141]	
	ISO	lbf	32,820 [35,630]	
		kN	146 [159]	

[ ]—Power boost

COOLANT & LUBRICANT CAPACITY		
Fuel Tank	103 (390)	
Engine Coolant	8.08 (30.6)	
Engine Oil	6.9 (26)	
Hydraulic System (Including Tank)	gal (l)	57.6 (218)
Hydraulic Tank	34 (131)	
Def/Adblue®	15.1 (57.2)	

UNDERCARRIAGE	
The X-leg type center frame is integrally welded with reinforced box-section track frames. The undercarriage includes lubricated rollers, idlers, track adjusters with shock absorbing springs and sprockets, and a track chain with double or triple grouser shoes.	
Center Frame	X-Leg type
Track Frame	Pentagonal box type
No. of Link on Each Side	49 ea
No. of Carrier Rollers on Each Side	2 ea
No. of Track Rollers on Each Side	8 ea
No. of Rail Guards on Each Side	2 ea

OPERATING WEIGHT (APPROXIMATE)			
Operating weight, including 18' 8" (5,700 mm) boom, 9' 6" (2,900 mm) arm, SAE heaped 1.31 yd <sup>3</sup> (1.0 m <sup>3</sup> ) bucket, 10,803 lb (4,900 kg) counterweight, 32" (800 mm) track shoe, lubricant, coolant, full fuel tank, full hydraulic tank, and all standard equipments.			
	Shoes	Operating Weight	Ground Pressure
Type	Width, in (mm)	lb (kg)	psi (kgf/cm <sup>2</sup> )
Triple Grouser	32" (800)	54,895 (24,900)	5.66 (0.40)
	36" (900)	55,094 (24,990)	5.05 (0.35)

# HX230L DIMENSIONS & WORKING RANGE

## DIMENSIONS

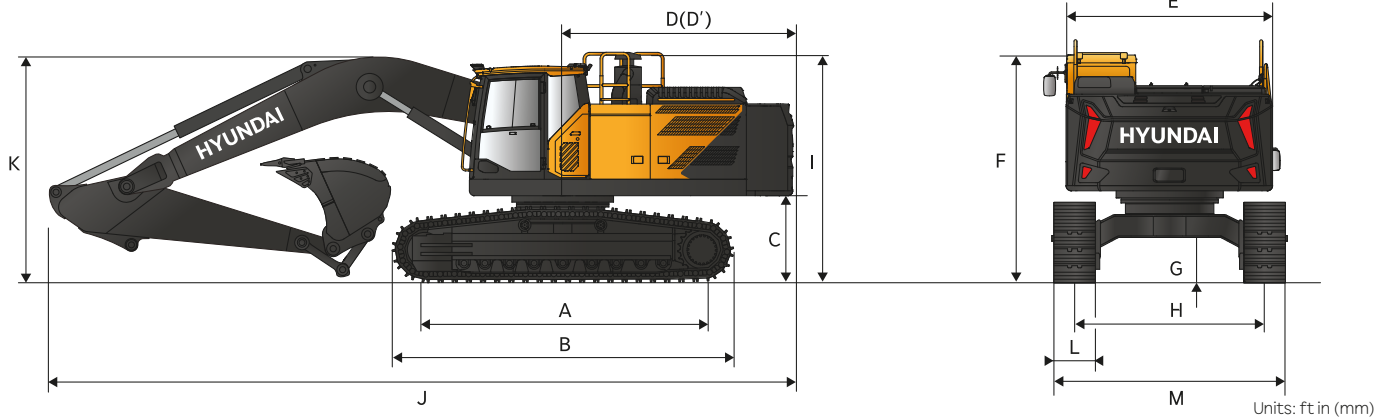

Units: ft in (mm)

A	Tumbler Distance	12' 0" (3,650)
B	Overall Length of Crawler (w/ Grouser)	14' 7" (4,445)
C	Ground Clearance of Counter Weight (w/ Grouser)	3' 6" (1,069.5)
D	Tail Swing Radius	9' 6" (2,906)
D'	Rear-End Length	9' 4" (2,855)
E	Overall Width of Upper Structure	10' 10" (3,300)
F	Overall Height of Cab	10' 5" (3,164)
G	Min. Ground Clearance	1' 6" (450.5)
H	Track gauge	8' 6" (2,600)
I	Overall Height of Guardrail (w/ Grouser)	10' 9" (3,288)

Boom Length	18' 8" (5,700)	
Arm Length	9' 6" (2,900)	11' 6" (3,500)
J Overall Length	31' 5" (9,580)	31' 6" (9,600)
K Overall Height of Boom	9' 7" (2,910)	11' 1" (3,390)

L	Track Shoe Width	32" (800)	36" (900)
M	Overall Width w/o Additional Foot Board	10' 6" (3,190)	10' 10" (3,290)

## WORKING RANGE

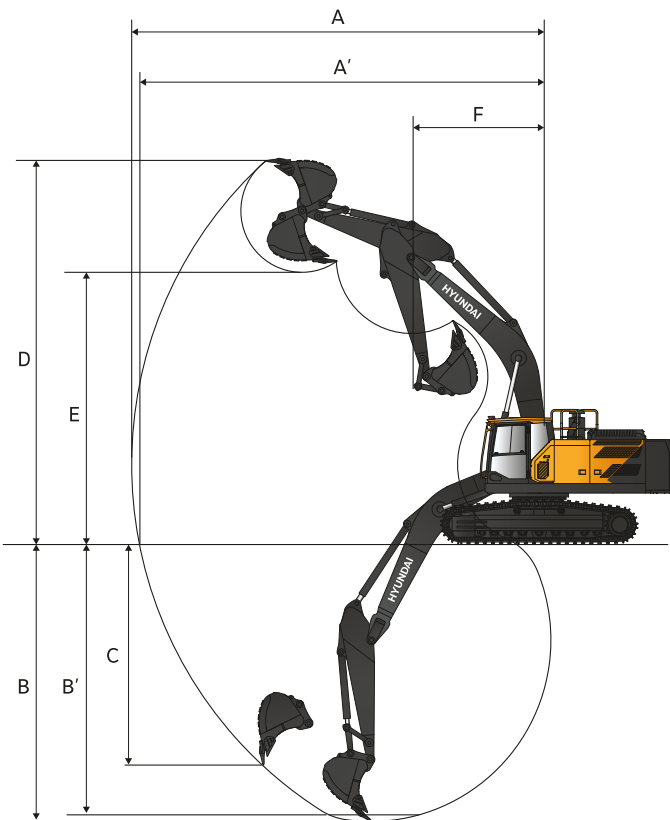









Units: ft in (mm)

Boom Length	18' 8" (5,700)	
Arm Length	9' 6" (2,900)	11' 6" (3,500)
A Max. Digging Reach	32' 6" (9,895)	34' 1" (10,400)
A' Max. Digging Reach on Ground	31' 11" (9,720)	33' 7" (10,235)
B Max. Digging Depth	21' 9" (6,620)	23' 8" (7,220)
B' Max. Digging Depth (8° level)	21' 1" (6,425)	23' 1" (7,045)
C Max. Vertical Wall Digging Depth	19' 0" (5,790)	21' 10" (6,650)
D Max. Digging Height	31' 3" (9,535)	31' 11" (9,735)
E Max. Dumping Height	22' 4" (6,805)	22' 10" (6,950)
F Min. Swing Radius	11' 8" (3,560)	11' 10" (3,615)

# HX230L LIFTING CAPACITY

 Rating over front  Rating over-side or 360 degree

## 18' 8" (5.7 m) boom, 9' 6" (2.9 m) arm equipped with 10,802 lb (4,900 kg) counterweight and 32" (800 mm) triple grouser shoe

Lift-point height ft (m)	Lift-point radius										At max. reach		
	5 ft (1.5 m)		10 ft (3.0 m)		15 ft (4.5 m)		20 ft (6.0 m)		25 ft (7.5 m)		Capacity	Reach	
													ft (m)
25 lb							*11,820	*11,820			*10,290	*10,290	20.34
(7.5) kg							*(5,360)	*(5,360)			*(4,670)	*(4,670)	(6.20)
20 lb							*13,030	*13,030			*9,590	*9,590	23.98
(6.0) kg							*(5,910)	*(5,910)			*(4,350)	*(4,350)	(7.31)
15 lb							*14,300	13,390	*13,230	9,480	*9,450	8,540	26.21
(4.5) kg							*(6,490)	(6,070)	*(6,000)	(4,300)	*(4,290)	(3,880)	(7.99)
10 lb					*20,900	19,510	*16,280	12,820	14,030	9,240	*9,700	7,830	27.38
(3.0) kg					*(9,480)	(8,850)	*(7,390)	(5,810)	(6,360)	(4,190)	*(4,400)	(3,550)	(8.35)
5 lb					*24,820	18,330	*18,260	12,260	13,730	8,960	*10,340	7,590	27.63
(1.5) kg					*(11,260)	(8,310)	*(8,280)	(5,560)	(6,230)	(4,070)	*(4,690)	(3,440)	(8.42)
0 lb			*14,520	*14,520	*26,700	17,70	18,720	11,860	13,510	8,760	*11,520	7,740	26.98
kg			*(6,580)	*(6,580)	*(12,110)	(8,030)	(8,490)	(5,380)	(6,130)	(3,970)	*(5,220)	(3,510)	(8.22)
-5 lb	*15,850	*15,850	*25,160	*25,160	*26,470	17,530	18,540	11,70	13,450	8,710	12,930	8,390	25.35
(-1.5) kg	*(7,190)	*(7,190)	*(11,410)	*(11,410)	(12,000)	(7,950)	(8,410)	(5,310)	(6,100)	(3,950)	(5,860)	(3,810)	(7.73)
-10 lb	*27,120	*27,120	*33,670	*33,670	*24,190	17,690	*17,990	11,80			*14,780	9,920	22.54
(-3.0) kg	*(12,300)	*(12,300)	*(15,270)	*(15,270)	*(10,970)	(8,030)	*(8,160)	(5,350)			*(6,700)	(4,500)	(6.87)
-15 lb			*25,710	*25,710	*18,770	18,230					*14,380	13,830	18.01
(-4.5) kg			*(11,660)	*(11,660)	*(8,520)	(8,270)					*(6,520)	(6,270)	(5.49)

## 18' 8" (5.7 m) boom, 11' 6" (3.5 m) long arm equipped with 10,802 lb (4,900 kg) counterweight and 32" (800 mm) triple grouser shoe.

Lift-point height ft (m)	Lift-point radius										At max. reach		
	5 ft (1.5 m)		10 ft (3.0 m)		15 ft (4.5 m)		20 ft (6.0 m)		25 ft (7.5 m)		Capacity	Reach	
													ft (m)
25 lb											*8.650	*8.650	22.54
(7.5) kg											*(3,930)	*(3,930)	(6.87)
20 lb									*10.410	9.750	*8.190	*8.190	25.87
(6.0) kg									*(4,720)	(4,420)	(3,720)	*(3,720)	(7.89)
15 lb							*12.940	*12.940	*12.150	9.590	*8.130	7.770	27.95
(4.5) kg							*(5,870)	*(5,870)	*(5,510)	(4,350)	*(3,690)	(3,520)	(8.52)
10 lb			*28.380	*28.380	*18.810	*18.810	*15.060	12.970	*13.160	9.290	*8.370	7.160	29.05
(3.0) kg			*(12,880)	*(12,880)	*(8,530)	*(8,530)	*(6,830)	(5,880)	*(5,970)	(4,210)	*(3,790)	(3,250)	(8.85)
5 lb					*23.230	18.570	*17.290	12.330	13.740	8.960	*8.910	6.930	29.28
(1.5) kg					*(10,540)	(8,420)	*(7,840)	(5,590)	(6,230)	(4,070)	*(4,040)	(3,150)	(8.92)
0 lb			*17.590	*17.590	*25.960	17.710	18.710	11.830	13.450	8.700	*9.880	7.030	28.66
kg			*(7,980)	*(7,980)	*(11,780)	(8,030)	(8,490)	(5,370)	(6,100)	(3,940)	*(4,480)	(3,190)	(8.74)
-5 lb	*15.510	*15.510	24.740	*24.740	*26.600	17.360	18.410	11.580	13.300	8.560	*11.550	7.530	27.14
(-1.5) kg	*(7,040)	*(7,040)	*(11,220)	*(11,220)	*(12,060)	(7,870)	(8,350)	(5,250)	(6,030)	(3,880)	*(5,240)	(3,410)	(8.27)
-10 lb	*24.120	*24.120	*35.690	33.690	*25.240	17.390	18.400	11.570			13.430	8.660	24.55
(-3.0) kg	*(10,940)	*(10,940)	*(16,190)	(15,280)	*(11,450)	(7,890)	(8,350)	(5,250)			(6,090)	(3,930)	(7.48)
-15 lb	*35.390	*35.390	*29.900	*29.900	*21.350	17.770	*15.300	11.880			*14.280	11.300	20.47
(-4.5) kg	*(16,050)	*(16,050)	*(13,560)	*(13,560)	*(9,680)	(8,060)	(6,940)	(5,390)			*(6,480)	(5,130)	(6.24)

- Lifting capacities are based on ISO 10567.
- Lifting capacity does not exceed 75% of tipping load with the machine on firm, level ground or 87% of full hydraulic capacity.
- The lift-point is bucket pivot mounting pin on the arm (without bucket mass).
- (\*) indicates load limited by hydraulic capacity.

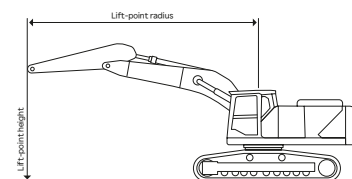

# HX230L STANDARD & OPTIONAL EQUIPMENT

## HYDRAULIC SYSTEM

FULL ELECTRO HYDRAULIC (FEH)	
Variable Power Control	●
Electric Pump Flow Control	●
Electric MCV with Electric Joystick	●
Attachment Mode Flow Control	●
Engine Auto Idle	●
Engine Auto Shutdown Control	●
JOYSTICK STEERING	●

## CAB & INTERIOR

ISO STANDARD CABIN	
Cabin Light (2 Working Lamps, HAL)	○
Cabin Light (2 Working Lamps, LED)	○
Cabin Light (6 Working Lamps, LED)	●
Beacon Lamp	○
Cabin Rain Shield	○
Pantograph Wiper Arms	●
Multi Channel Speaker (4 ea)	●
DAB Audio (Handsfree and Bluetooth)	●
Electric Horn	●
Safety Glass—Laminated Glass (front)	●
Sliding Fold-In Front Window	●
Sliding Slide Window (LH)	●
Lockable Door	●
Hot and Cool Box	●
Storage Compartment	●
Warnings	●
Communication Error	●
Low Battery / Clock	●
SEAT	
Leather Heating and Cooling Seat	●
Fabric Heating Seat	○
CABIN FOG (ISO) 10262	
Top Falling Object Guard	○
Front and Top Falling Object Guard	○
Wire Mesh Guard (Front Only)	○
CABIN ROPS (ISO) 12117-2	
ROPS (Roll Over Protective Structures)	●
AUTOMATIC CLIMATE CONTROL	
Air Conditioner and Heater	●
Defroster	●
AUTOMATIC STARTING AID (AIR GRID HEATER)	
Starting Aid (Air Grid Heater) for Cold Weather	●
Engine Coolant Heater and Plug Heater (110 V Plug Heater)	○

## CAB & INTERIOR

ADDITIONAL GAUGE PANEL (AGP)	
12" LCD Display	●
Secondary 12" Display	○
Engine RPM or Trip Meter / Accelerometer	●
Engine Coolant Temperature Gauge	●
Max Power / Low and High Speed / Engine Check indicator	●
Overload Warning with Alarm	●
Eco Gauge / Fuel Level / Hydraulic Oil Temperature Gauge	●
Air Cleaner Clogging	●
Fuel Warmer	●

## SAFETY

Battery Master Switch	●
Right and Rear View Camera	●
Smart Around View Camera (SAVM)	○
Around Radar (ADS)	○
Travel and Swing Alarm	●
Travel and Swing White Noise Alarm	○
Automatic Swing Brake	●
Boom Holding Valve	○
Arm Holding Valve	○
Overload Warning Device	●

## TECHNOLOGY

2D Machine Guidance	○
2D Machine Control	○
Bucket weighing and Payload system	○
Swing Boundary System	○
E Boundary (Working Barriers)	○
Auto Stop (Travel/Swing)	○
Lift Assist	○
Advanced Lift Assist	○
Equipment Health Monitoring (EHM)—Basic—Engine and Hydraulic Oil Status Check in Real Time	●
Equipment Health Monitoring (EHM) Premium—Basic + Main Pump and Swing motor monitoring	○

## OTHERS

Smart Key (with Digital Key)	○
Hydraulic Reversible Fan	○
Pre-Cleaner—Oil washed	○
Fine Swing (Free and Cushion Function)	●
Straight Travel	●
Hyundai Connect (Telematics)	●
Air Compressor	○

## OTHERS

Side Protector	●
Fuel Filler Pump	○
Heat Wire for Mirror	○

## FRONT ATTACHMENTS

Auxiliary Piping with Pedal (2-way)	●
Rotating Piping (4-way)	○
Quick Coupler	●
Quick Coupler Piping Only	○

## BOOMS

18' 8" (5,700 mm) Boom	●
------------------------	---

## ARMS

9' 6" (2,900 mm) Arm	●
11' 5" (3,500 mm) Long Arm	○

## BUCKETS

36" (0.91 m) 1.11 yd <sup>3</sup> (0.85 m <sup>3</sup> ) HD J Style 5 Teeth	○
42" (1.0 m) 1.31 yd <sup>3</sup> (1.05 m <sup>3</sup> ) HD J Style 5 Teeth	●
48" (1.2 m) 1.15 yd <sup>3</sup> (1.5 m <sup>3</sup> ) HD J Style 6 Teeth	○

## COUNTERWEIGHT

10,800 lb (4,900 kg) Heavy Counterweight	●
11,690 lb (5,300 kg) Heavy Counterweight*	○

\* Long Reach Only

## UNDERCARRIAGE

Heavy-duty Under Cover	●
------------------------	---

## TRACK SHOES

32" (800 mm) Shoe	●
36" (900 mm) Shoe	○

## TRACK GUARD

Two Single Track Guards Per Side	●
----------------------------------	---

## Dozer

Front Dozer	○
-------------	---

\* Standard and optional equipment may vary. Contact your Hyundai dealer for more information.

\* The machine may vary according to International standards.

\* The photos may include attachments and optional equipment that are not available in your area.

\* Materials and specifications are subject to change without advance notice.

\* All US measurements rounded off to the nearest pound or inch.

# HYUNDAI

6100 Atlantic Blvd., Norcross, GA 30071  
TEL (678) 823-7777 FAX (678) 823-7778



Printed in U.S.A.

building a comfortable tomorrow

HX230L EX-SP 05/2026 ASv1