

 **HD HYUNDAI**

Wheel Loader Family

HL930A | HL940A | HL955A | HL960A | HL965 | HL970A | HL975 | HL980A | HL985A



* Photo may include optional equipment

Select models also available in XT, TM, and HD versions

Bucket Range: 2.5 yd³ - 9.2 yd³ (1.9 m³ - 7.0 m³)

building a comfortable tomorrow

WHEEL LOADER FAMILY

Z-BAR LINKAGE | EXTENDED REACH (XT)

Hyundai wheel loaders are available in our standard, Z-bar linkage configuration, with XT (extended-reach) versions available for applications that require greater reach and higher dump heights. Whatever your need, there's a Hyundai wheel loader with the right combination of power, capacity and efficiency to get the job done.



HL930A



Net Power hp / kW 130 / 97 at 2,200 rpm	Operating Weight lb / kg 25,595 / 11,610 (XT) 25,795 / 11,700	Standard Bucket yd ³ / m ³ 2.50 / 1.90
Tipping Load / Straight lb / kg 20,615 / 9,350 (XT) 10,080 / 8,200	Dumping Clearance* ft / mm 8' 10" / 2,700 (XT) 9' 11" / 3,035	



HL955A



Net Power hp / kW 197 / 147 at 2,200 rpm	Operating Weight lb / kg 35,490 / 16,098 (XT) 36,355 / 16,490	Standard Bucket yd ³ / m ³ 3.7 / 2.8
Tipping Load / Straight lb / kg 26,430 / 11,988 (XT) 20,725 / 9,400	Dumping Clearance* ft / mm 9' 2" / 2,785 (XT) 11' / 3,360	



HL940A



Net Power hp / kW 156 / 116 at 2,200 rpm	Operating Weight lb / kg 29,985 / 13,601 (XT) 30,560 / 13,862	Standard Bucket yd ³ / m ³ 3.0 / 2.3
Tipping Load / Straight lb / kg 23,085 / 10,471 (XT) 17,970 / 8,150	Dumping Clearance* ft / mm 9.1' / 2,765 (XT) 11' 11" / 3,370	



HL960A



Net Power hp / kW 222 / 166 at 2,200 rpm	Operating Weight lb / kg 43,720 / 19,831 (XT) 44,160 / 20,031	Standard Bucket yd ³ / m ³ 4.3 / 3.3
Tipping Load / Straight lb / kg 34,815 / 15,792 (XT) 28,550 / 12,950	Dumping Clearance* ft / mm 9' 8" / 2,935 (XT) 11' / 3,365	

Scan QR codes to download spec sheets for each model



HL965



Net Power hp / kW 269 / 198 at 2,100 rpm	Operating Weight lb / kg 45,700 / 20,730	Standard Bucket yd ³ / m ³ 4.7 / 3.6
Tipping Load / Straight lb / kg 35,615 / 16,155 /	Dumping Clearance ft / mm 9' 8" / 2,955	



HL980A



Net Power hp / kW 351 / 262 at 2,200 rpm	Operating Weight lb / kg 69,120 / 31,352 (XT) 69,450 / 31,502	Standard Bucket yd ³ / m ³ 7.3 / 5.6
Tipping Load / Straight lb / kg 53,895 / 24,446 (XT) 47,735 / 21,650	Dumping Clearance* ft / mm 10' 10" / 3,300 (XT) 11' 11" / 3,620	



HL970A



Net Power hp / kW 322 / 240 at 2,100 rpm	Operating Weight lb / kg 54,455 / 24,700 (XT) 55,120 / 25,000	Standard Bucket yd ³ / m ³ 5.5 / 4.2
Tipping Load / Straight lb / kg 43,100 / 19,550 (XT) 35,830 / 16,250	Dumping Clearance* ft / mm 10' 1" / 3,080 (XT) 11' 9" / 3,570	



HL985A



Net Power hp / kW 420 / 321 at 2,100 rpm	Operating Weight lb / kg 77,935 / 35,350	Standard Bucket yd ³ / m ³ 9.20 / 7.0
Tipping Load / Straight lb / kg 55,230 / 25,050	Dumping Clearance* ft / mm 11' / 3,353	



HL975



Net Power hp / kW 331 / 247 at 2,100 rpm	Operating Weight lb / kg 58,430 / 26,500 (XT) 60,175 / 27,295	Standard Bucket yd ³ / m ³ 6.3 / 4.8
Tipping Load / Straight lb / kg 44,090 / 20,000 (XT) 40,455 / 18,350	Dumping Clearance ft / mm 10' 3" / 3,120 (XT) 11' 5" / 3,485	

WHEEL LOADER FAMILY

TOOL MASTER MODELS

If you need the versatility of a tool-carrier design, Hyundai offers three models, the HL930A TM, HL940A TM and HL955A TM – with our Tool Master boom design, with parallel linkage for increased lifting capacity, improved load stability, rapid dumping capability and enhanced visibility.



HL930ATM



Net Power
hp / kW
130 / 97 at 2,200 rpm

Operating Weight
lb / kg
26,370 / 11,960

Tipping Load / Straight
lb / kg
17,860 / 8,100

Dumping Clearance*
ft / mm
9' 2" / 2,785

Standard Bucket
yd³ / m³
2.5 / 1.9



HL940ATM



Net Power
hp / kW
154 / 115 at 2,200 rpm

Operating Weight
lb / kg
30,420 / 13,800

Tipping Load / Straight
lb / kg
18,960 / 8,600

Dumping Clearance*
ft / mm
9' 3" / 2,840

Standard Bucket
yd³ / m³
3.0 / 2.3



HL955ATM



Net Power
hp / kW
197 / 147 at 2,200 rpm

Operating Weight
lb / kg
36,380 / 16,500

Tipping Load / Straight
lb / kg
24,255 / 11,000

Dumping Clearance*
ft / mm
9' 4" / 2,850

Standard Bucket
yd³ / m³
3.7 / 2.8





HEAVY-DUTY

For customers working in forestry, scrap handling and other tough applications, the Hyundai HL955A and HL965A are available in HD (heavy-duty) versions that include extra-heavy-duty axles and accommodate a full guarding package, including guarding for the cab, underbelly, cylinders and center pivot.



HL955AHD / HDXT



Net Power hp / kW 197 / 147 at 2,200 rpm	Operating Weight lb / kg (HD) 34,833 / 15,800 (HDXT) 36,355 / 16,490	Standard Bucket yd ³ / m ³ 3.7 / 2.8
Tipping Load / Straight lb / kg (HD) 25,025 / 11,350 (HDXT) 20,720 / 9,400	Dumping Clearance* ft / mm (HD) 9' 2" / 2,785 (HDXT) 11' / 3,360	



HL960AHD / HDXT



Net Power hp / kW 222 / 166 at 2,200 rpm	Operating Weight lb / kg (HD) 42,880 / 19,450 (HDXT) 44,710 / 20,280	Standard Bucket yd ³ / m ³ 4.3 / 3.3
Tipping Load / Straight lb / kg (HD) 31,750 / 14,400 (HDXT) 28,775 / 13,050	Dumping Clearance* ft / mm (HD) 9' 8" / 2,935 (HDXT) 11' / 3,365	

Scan QR codes to download spec sheets for each model



BUILT FOR EVERYONE

Cabs on the Hyundai wheel loaders are all about operator comfort and control. They're up to 10-percent larger than previous models, and offer additional floor space and improved visibility. In-cab sound levels are more than 2 dB lower, making this one of the quietest cabs in the industry.



* Photo may include optional equipment.





PROVEN PERFORMANCE ENHANCED BY TECHNOLOGY

Hyundai wheel loaders are powered by Cummins Performance Series Engines, which deliver up to 10 percent more power and nearly 20 percent more torque, while using less fuel and meeting Tier 4 Final and EU Stage V emissions standards. Other improvements with the Hyundai include quieter operation – just 68 dB in the cab – added safety features and functions like Smart Power that help reduce fuel consumption and increase productivity.



Hi MATE

Hi MATE Remote Management System

Hi MATE, the proprietary Hyundai remote management system, is provided free of charge for five years with all new Hyundai wheel loaders. This GPS-based software system allows equipment owners and service personnel to track and monitor Hyundai construction machines at any time and in any location, monitoring key machine components such as the engine, hydraulics and electrical system. Hi MATE saves time and money for the owner by promoting greater preventive maintenance to reduce equipment downtime.

24/7

COMPLETE FLEET DIAGNOSTICS



Hi MATE mobile (cellular) is free for five years, and optional Hi MATE satellite is free for two years.



Eco Gauge

Using this function, the operator can monitor fuel consumption in real time or review historical data. Displayed values include engine torque, fuel efficiency, average and total fuel consumed. Hourly and daily fuel consumption also is viewable through the menu.



Electro-Hydraulic Control

With improved precision and ease of operation, the electrohydraulic control system contributes to increased productivity and reduced operator fatigue.



Smart Power Mode

This feature reduces fuel consumption by adjusting the engine speed in heavy-duty applications, such as digging. This can save fuel while also balancing traction and breakout forces for greater productivity.

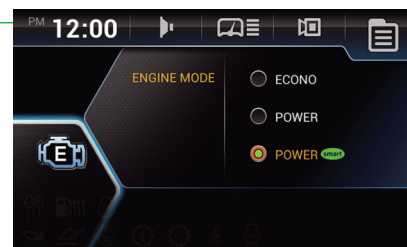

Accurate Onboard Weighing System

Hyundai's enhanced, proprietary onboard weighing system comes standard on all Hyundai models. Accurate to +/- 2.5 percent (5% range), the automatic-manual cumulative weighing function enhances operating efficiency.



FOUR CAMERAS



OBJECT
DETECTION

360° SEAMLESS VIEW

AAVM

Our AAVM system, now enhanced with radar on our Hyundai machines, sports four cameras, 360-degree views, and motion detection because risk is easier to avoid when you see it coming.



GREATER COMFORT, GREATER CONTROL





Intelligent, Wide Touchscreen Monitor

The automotive-quality seven-inch (177 mm) touchscreen display on the Hyundai wheel loaders is easy to read and allows monitoring and control of a wide range of functions, including the eco gauge, power modes, weighing system and more.



Electro-Hydraulic Control Lever

The EH (Electro-Hydraulic) control lever, standard across all Hyundai wheel loader models, facilitates easy operation of attachments with integrated third-spool proportional control. This feature enhances productivity and reduces operator fatigue. For those who prefer a different setup, a Pilot (Hydraulic Joystick) control is available as an option on all HL930A, HL940A models, and the HL955A, HL955AXT.



Automatic Engine Shut Down

Engine Auto Shutdown occurs when the engine is in an idle state for longer than the selected time, adjustable from 2 – 40 mins, with all power being shut off to prevent battery drain.

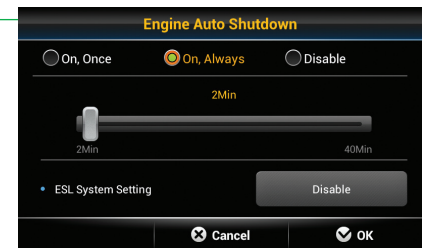

I.C.C.O. (Intelligent Clutch Cut Off) Mode

The I.C.C.O. system ensures less fuel consumption during operations and minimizes power loss in the torque converter. Additionally, it maintains lower temperatures on the brakes and axles, reducing wear and tear. With more power available for hydraulics, you can achieve smooth control of vehicle speed, especially with high engine RPMs on flat ground, leading to significantly improved productivity.

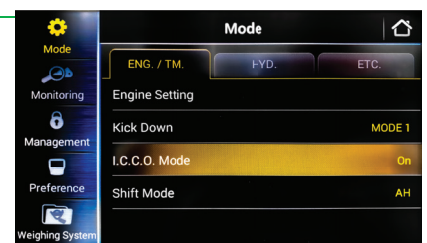

Fully Adjustable Seat Armrest, Seat and Control Lever

All Hyundai wheel loaders are equipped with large, comfortable, high-quality seats with headrests. The armrest and controller are mounted to the seat so they move with the operator, which improves comfort and reduces fatigue.



Premium-Quality ZF Axles

A conventional rear axle and a hydraulic locking front differential come standard. Optionally, you can choose limited slip differential front and rear axles for optimum traction and versatility.



Sintered Brake Discs

The Hyundai features longer-lasting sintered brake discs designed to produce less heat and vibration, which improves overall brake durability. This service-friendly design contributes to reduced downtime for brake maintenance and reduces overall cost of ownership.

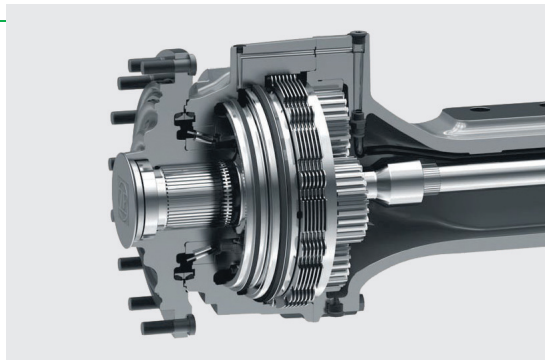

ZF Transmission

The ZF transmission system offers both fully automated and manual powershift options, ensuring smooth shifting with no traction interruption. The deep-toothed helical gears contribute to lower noise emissions, while the system's low fuel consumption and modular, compact construction lead to significant cost savings.

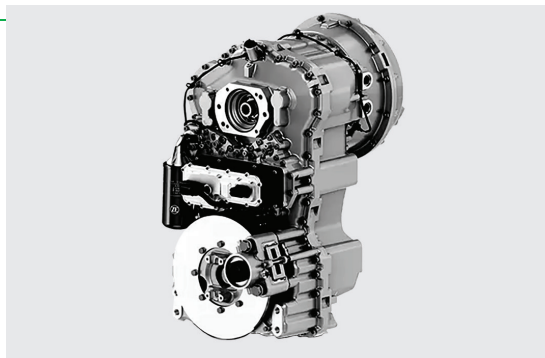

Sealed Drive-Line Center Bearing

Hyundai's wheel loaders are designed for extended service life. A sealed drive-line center bearing with a reinforced support area contributes to improved long-term reliability.

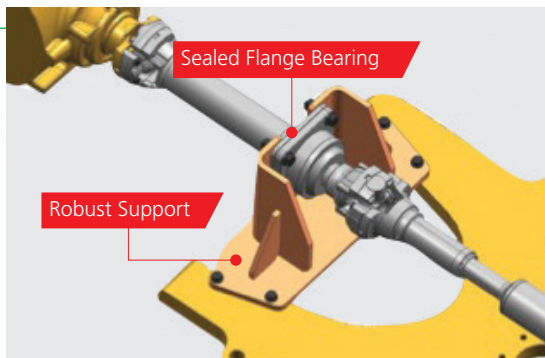

Improved Bucket Fill Factor

Hyundai's improved bucket design features an innovative wider opening, curved side plates and enhanced spill guard to maximize bucket capacity and reduce material loss when traveling. Durability is also enhanced through the use of wear-resistant HARDOX 400 grade steel in key structural areas of the bucket.

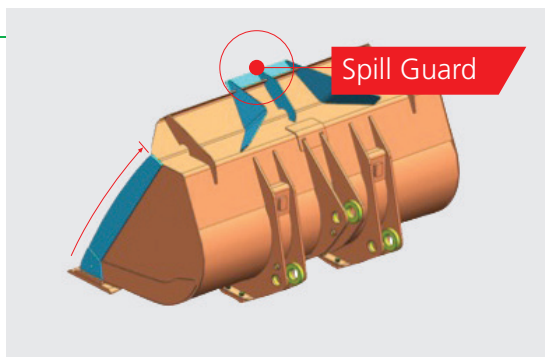

VERSATILE WORKHORSES DELIVER RESULTS



As the workhorses in the industry, Hyundai wheel loaders are found all over North America in severe-duty applications such as road building, sand and gravel pits, quarries, mines, recycling yards, lumber yards, feedlots and more. Customers choose Hyundai machines for their power, productivity and ease of operation. The Hyundai continues that legacy while delivering an enhanced operator environment, productivity improvements and additional efficiencies that make these machines the best value on the market.





SAFETY, SERVICEABILITY AND RELIABILITY

Enhanced safety features on the Hyundai include an improved, standard rearview camera that delivers higher resolution and better nighttime visibility, standard heated mirrors that provide a clearer view for safer operation in cold weather conditions, large access steps to the cab, convenient grab handles and upper guard rails near the engine compartment, and programmable speed-limit setting.

68 dB

Quiet enough for
a conversation



* Photo may include optional equipment.



Air Conditioning System

Hyundai's wheel loaders have optimized air flow to maximize heating and cooling performance. The air conditioning system is located on the right side of the cab to allow for easier maintenance and filter replacement. The capacity of the inner filter also was increased. Filter material was improved for superior filtering performance.



Fully Sealed Engine Room with Tilt-Back Hood

The Hyundai has improved accessibility to the sealed engine room with a tilt-back hood to allow for easy cleaning and maintenance. The engine compartment was designed to prevent any possibility of fire due to contamination. The wide open access when the hood is up also enhances serviceability of the engine and cooling room.

Centralized and Easy Access to Service Points

All of the service points for the electric and hydraulic systems are located in easy-to-reach areas for optimum accessibility and maintenance.

Cooling Package Reversing Fan

The reversing fan has adjustable intervals from 30 minutes to 5 hours, with run times of 30 seconds to 5 minutes, depending on operational conditions. All of this is adjustable on the monitor in the cab.

Engine Air Filter with Increased Service Life

The Hyundai has a large-volume air cleaner, automatic dust ejector, and a three-stage turbo pre-cleaner to improve the replacement cycle and durability of replacement parts.

DRIVEN BY VISION, BUILT TO PERFORM



For three decades HD Hyundai Construction Equipment North America has brought Hyundai's spirit to the United States and Canada. Backed by Hyundai Heavy Industries' and founder Chung Ju-yung's commitment to quality and innovation we build machines that meet the highest expectations and drive business growth every day.

Backed by HD Hyundai

An international powerhouse across many heavy industries.



Refinery



Shipbuilding



Construction Equipment



Offshore Engineering



Engine and Machinery



Electro Electric Systems



Industrial Plant Engineering



Green Energy

Support

Hyundai construction equipment is available and serviced through a network of more than 100 dealerships at over 200 locations across the U.S. and Canada. When you invest in a Hyundai machine, you're getting the durability you can rely on. Here's what sets Hyundai apart:

- Value: Every machine comes packed with more standard features.
- Warranty: Enjoy an industry-leading 3-year/3,000-hour standard warranty, plus a 5-year/10,000-hour structural warranty, with the option to add Hyundai Extend, our extended-warranty program.
- Expert Service: Our skilled dealer service teams, backed by Hyundai field support, are here to help.
- Parts Support: With an average 96% fill rate for parts orders, our warehouses in suburban Atlanta and Mississauga, Ontario, stock over \$43 million in parts inventory to keep you running.



6100 Atlantic Blvd., Norcross, GA 30071
TEL (678) 823-7777 FAX (678) 823-7778
na.HD-HyundaiCE.com



Printed in U.S.A.



HL_Family-1149-WL-FB 9/2024v24