

CONTENTS

Foreword	0-1
Emission-related components warranty (USA and CANADA only)	0-1-1
Before servicing this machine	0-2
EC regulation approved	0-3
Table to enter S/No and distribution	0-4
Machine data plate	0-5
Guide (direction, S/No, symbol)	0-6

SAFETY HINTS

1. Safety instructions	1-2
2. Safety labels	1-31

OPERATION

1. Instruction for new machine	2-1
2. Check before starting the engine	2-2
3. Starting and stopping the engine	2-3
4. Mode selection system	2-7
5. Operation of the working device	2-12
6. Traveling of the machine	2-13
7. Efficient working method	2-16
8. Operation in the special work sites	2-20
9. Normal operation of excavator	2-22
10. Attachment lowering	2-23
11. Storage	2-24
12. RCV lever operating pattern	2-26
13. Exhaust system cleaning	2-28

CONTROL DEVICES

1. Cab devices	3-1
2. Cluster	3-2
3. Switches	3-40
4. Levers and pedals	3-45
5. Others	3-48

MAINTENANCE

1. Instruction	4-1
2. Tightening torque	4-6
3. Fuel, coolant and lubricants	4-9

4. Maintenance check list	4-11
5. Maintenance chart	4-17
6. Service instruction	4-20
7. Electrical system	4-51
8. Air conditioner and heater	4-54

TRANSPORTATION

1. Preparation for transportation	5-1
2. Dimension and weight	5-2
3. Loading the machine	5-8
4. Fixing the machine	5-10
5. Loading and unloading by crane	5-11

TROUBLESHOOTING GUIDE

1. Engine	6-1
2. Electrical system	6-2
3. Others	6-3

SPECIFICATIONS

1. Major components	7-1
2. Specifications	7-2
3. Working range	7-8
4. Weight	7-12
5. Lifting capacities	7-13
6. Bucket selection guide	7-35
7. Undercarriage	7-36
8. Specification for major components	7-38
9. Recommended oils	7-41

HYDRAULIC BREAKER AND QUICK CLAMP

1. Selecting hydraulic breaker	8-1
2. Circuit configuration	8-2
3. Maintenance	8-3
4. Precaution while operating the breaker	8-4
5. Quick clamp	8-6

INDEX	9-1
-------------	-----

FOREWORD

This manual contains a number of instructions and safety recommendations regarding driving, handling, lubrication, maintenance, inspection and adjustment of the excavator.

This manual provides important instructions regarding the excavator, including important safety warnings and instructions for proper operation and maintenance of the excavator.

Keep this manual handy and have all personnel read it periodically.

If you sell the machine, you must provide this manual with the excavator.

This machine complies with EC directive "2006/42/EC".

1. **Read and understand** this manual before operating the machine.

This operator's manual may contain attachments and optional equipment that are not available in your area. Please consult your local Hyundai distributor for those items you require.

▲ Improper operation and maintenance of this machine can be hazardous and could result in serious injury or death.

The procedures and precautions given in this manual apply only to intended uses of the machine.

If you use your machine for any unintended uses that are not specifically prohibited, you must be sure that it is safe for you and others. In no event should you or others engage in prohibited uses of actions as described in this manual.

Some illustrations in this manual show details or attachments that can be different from your machine. Covers and guards might have been removed for illustrative purposes. Never operate the machine without the proper covers and guards in place.

2. Inspect the jobsite and follow the safety recommendations in chapter 1, Safety hints before operating the machine.

3. Use genuine Hyundai spare parts for the replacement of parts.

Hyundai will not accept any responsibility for defects resulting from non-genuine parts or non-workmanlike repair.

In such cases Hyundai cannot assume liability for any damage.

Continuing improvements in the design of this machine can lead to changes in detail which may not be reflected in this manual. Consult Hyundai or your Hyundai distributor for the latest available information for your machine or for questions regarding information in this manual.

EMISSION-RELATED COMPONENTS WARRANTY (USA AND CANADA ONLY)

This machine complies with all applicable Environmental Protection Agency (EPA) regulations for warranties for emission-related components. The term of this warranty is 3,000 hours or five years, whichever occurs first.

This warranty does not cover damage arising from accident, misuse or negligence, use of non-Hyundai parts, or alterations not authorized by Hyundai.

※ Emission-related components according to the EPA regulation.

1. Air-induction system.
2. Fuel system.
3. Ignition system.
4. Exhaust gas recirculation systems.
5. After treatment devices.
6. Crankcase ventilation valves.
7. Sensors.
8. Electronic control units.

BEFORE SERVICING THIS MACHINE

It is the responsibility of the owner and all service and maintenance personnel to avoid accidents and serious injury by keeping this machine properly maintained.

It also is the responsibility of the owner and all service and maintenance personnel to avoid accidents and serious injury while servicing the machine.

No one should service or attempt to repair this machine without proper training and supervision.

All service and maintenance personnel should be thoroughly familiar with the procedures and precautions contained in this manual.

All personnel also must be aware of any federal, state, provincial or local laws or regulations covering the use and service of construction equipment.

The procedures in this manual do not supersede any requirements imposed by federal, state, provincial or local laws.

Hyundai can not anticipate every possible circumstance or environment in which this machine may be used and serviced.

All personnel must remain alert to potential hazards.

Work within your level of training and skill.

Ask your supervisor if you are uncertain about a particular task. Do not try to do too much too fast.

Use your common sense.

※ How to set the language of cluster

Selection of preferred language will change the language on all displays.



※ Please refer to the page 3-33 for the cluster.

EC REGULATION APPROVED

- Noise level (EN474-1 : 2006 and 2000/14/EC) are as followings.

LWA : 104dB (EU only)

LPA : 72dB

- The value of vibrations transmitted by the operator's seat are lower than standard value of (EN474-1 : 2006 and 2002/44/EC)



EC Declaration of Conformity
(Original instruction)

This declaration of conformity is issued under the sole responsibility of manufacturer:

HYUNDAI CONSTRUCTION EQUIPMENT CO., LTD.
12th Fl., Hyundai Bldg. 75, Yulgok-ro, Jongno-gu,
Seoul 03058, Korea

Hyundai Construction Equipment Europe N.V located at Hyundailaan 4, 3980 Tessenderlo, Belgium, as authorized representative in the European Community is authorized to compile the technical construction file and declares that the product:

Type: *****
Model: *****
Serial number (PIN): *****

is in conformity with the relevant provisions of the Community harmonization legislation:

2006/42/EC - Machinery directive
2014/30/EU - Electromagnetic compatibility directive
2000/14/EC - Noise emission outdoor equipment directive
2002/44/EU - Exposure of workers to vibration risks directive
their amendments, and other applicable directives.

EMC (2014/30/EU)

Certificate number: *****
Date: DD/MM/YYYY
Notified body: *****

Noise levels (2000/14/EC)

Certificate number: *****
Date: DD/MM/YYYY
Conformity assessment proc.: Annex VIII Full Quality Assurance
Notified body: *****

Measured sound power level: nnn.n dB(A)
Guaranteed sound power level: nnn.n dB(A)

Engine information

Manufacturer : *****
Engine model name: *****
Type-approval number: *****
Stage (Regulation) : STAGE ** (**/**/**)
Gross Power (SAE J1995): ***kW / ****rpm
Net Power (SAE J1349): ***kW / ****rpm

Harmonized standards, other technical standards and specifications applied:

EN 474-1:2006+A*:**** (EMM - Safety - Part 1); EN 474-3:2006+A*:**** (EMM - Safety - Part 3); EN ISO 3471:2008 (EMM - ROPS: Lateral/Vertical/Longitudinal loads); EN ISO 3449:2008 (EMM - FOPS: Level II cabin); ISO 2631-1:1997 & ISO 2631-1:1997/Amd1 :2010 (Whole-body vibration); EN ISO 5349-1:2001 & EN ISO 5349-2:2001 & EN ISO 5349-2:2001/A1:2015 (Hand-arm vibration)

Managing Director
Place, date of issue: Tessenderlo Belgium, DD MM YYYY

TABLE TO ENTER SERIAL NO. AND DISTRIBUTOR

Machine Serial No.	
Engine Serial No.	
Manufacturing year	
Manufacturer Address	HYUNDAI CONSTRUCTION EQUIPMENT CO., LTD. 12th Fl., Hyundai Bldg. 75, Yulgok-ro, Jongno-gu, Seoul 03058, Korea
Distributor for U.S.A Address	Hyundai Construction Equipment Americas, Inc 6100 Atlantic Boulevard Norcross GA 30071 U.S.A
Distributor for Europe Address	Hyundai Construction Equipment Europe N. V. Hyundailaan 4 3980 Tessenderlo Belgium
Dealer Address	

MACHINE DATA PLATE

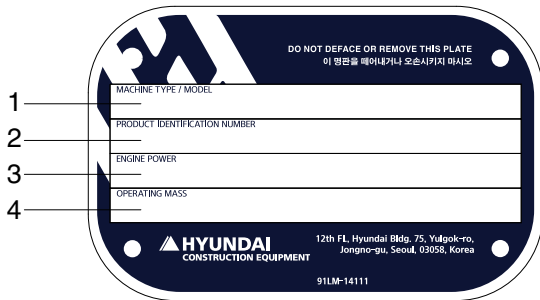

For general



For FOPS/FOG



For EU only

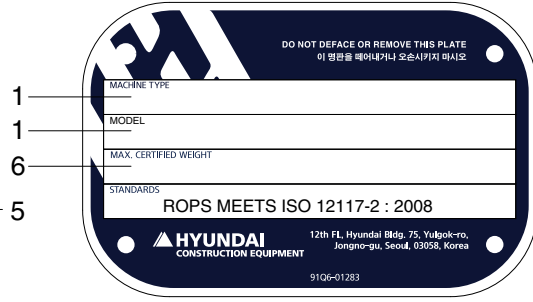

For ROPS



For RUSSIA, KAZAKHSTAN, BELARUS

300A0MD01

- | | | | | | |
|---|----------------------|---|-------------------------------|---|--------------------------|
| 1 | Machine type / model | 2 | Product identification number | 3 | Engine power |
| 4 | Operating mass | 5 | Manufacturing year | 6 | Maximum certified weight |

※ The machine serial number assigned to this particular machine should be used when requesting information or ordering service parts for this machine from your authorized HYUNDAI dealer. The machine serial number is also stamped on the frame.

1. DIRECTION

The direction of the arrows (as they are indicated) are with the travel motors to the rear and the boom facing the opposite direction. Refer to the right illustration.

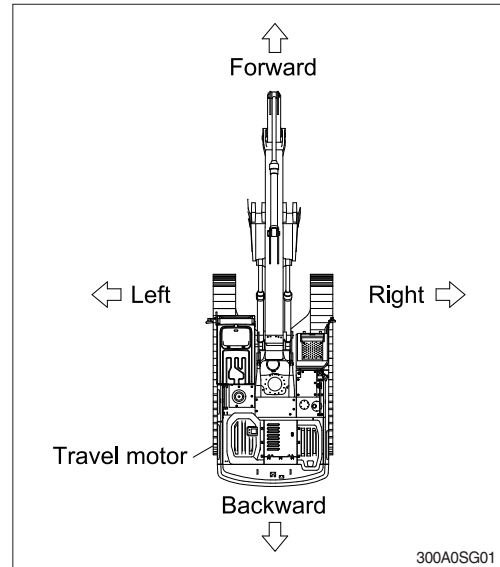

2. SERIAL NUMBER

Provides the serial number when ordering parts or seeking assistance.

1) MACHINE SERIAL NUMBER

The numbers are located below the right window of the operator's cab.

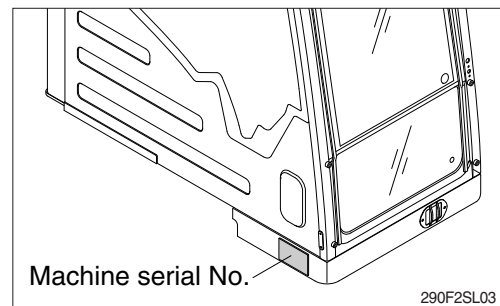

2) ENGINE SERIAL NUMBER

The numbers are located on the engine name plate.

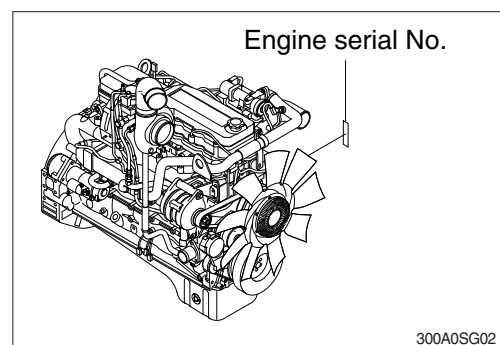

3. INTENDED USE

This machine is designed to be used mainly for the following work:

- Excavation work
- Loading work
- Leveling work
- Drainage work
- Lifting work
- Demolition work

※ Please refer to section, Efficient working method further details.

4. SYMBOLS

- ▲ Provides important safety warnings. Failure to follow these warnings could result in serious injury or death.
- △ Provides important instructions to prevent damage to the equipment.
- ※ Provides useful information for the operator.

 **WARNING**

CALIFORNIA PROPOSITION 65

Breathing diesel engine exhaust exposes you to chemicals known to the State of California to cause cancer and birth defects or other reproductive harm.

- Always start and operate the engine in a well-ventilated area.
- If in an enclosed area, vent the exhaust to the outside.
- Do not modify or tamper with the exhaust system.
- Do not idle the engine except as necessary.

For more information go to www.P65warnings.ca.gov/diesel.

SAFETY INSTRUCTIONS

Safety Message

Intended Use

Machines should be operated in accordance with the procedures described in the operator manual.

The products described in the operator manual are designed and manufactured mainly for the following purposes:

- Excavation work
- Loading work
- Leveling work
- Drainage work
- Lifting work
- Demolition work

Do not operate the machine for any purpose other than those stated above or in areas where potential hazards have been identified. Make sure that you comply strictly with all safety instructions at all times. Please contact Hyundai Construction Equipment Co., Ltd. or your local dealer for more information.

Hyundai strictly prohibits the use or operation of the machine in any of the following circumstances:

- Operation by an unskilled worker
- Lifting a worker up
- Transporting flammable or dangerous materials
- Driving down or extracting piles with the bucket
- Towing damaged vehicles

Safety guidelines

Most safety accidents related to the operation, maintenance/ inspection, and repair of the machine result from a failure to comply with the safety instructions or to take adequate preventive measures. Safety accidents can be prevented by eliminating potentially hazardous situations. The operator should attend all mandatory training courses on the operation of the machine, and fully understand how to use the tools.

Improper operation, refueling, inspection or repair of this machine may cause serious injury or death.

Do not attempt to operate, refuel, inspect or repair this machine before reading and understanding the product information on such tasks.

This manual describes preventive measures and warnings about the product.

Failure to comply with the warnings about potential risks may result in serious injury or death.

General Safety Information

Unauthorized modification

Any attempt to modify the machine, including the use of unauthorized accessories or spare parts, may have adverse effects on the conditions of the machine and its ability to function as it was designed.

Do not attempt to modify the machine in any way without advanced written consent of the company.

Unauthorized modification will void the manufacturer's warranty.

Never modify the operator's cabin by welding, grinding, drilling holes or adding attachments unless instructed by Hyundai Construction Equipment in writing. Changes to the cabin can cause loss of operator protection from roll-over and falling objects, and result in serious injury or death.

The user is responsible for all damages and liabilities resulting from unauthorized modifications.

The attachment, the accessory, or the spare part has been made or distributed by Hyundai Construction Equipment and has been installed according to approved methods described in a publication available from Hyundai Construction Equipment.

Any modification must be approved by the company in writing.

ROPS/FOPS

The cabin is designed to provide sufficient space to minimize impacts pursuant to ISO 12117-2 of Rollover Protective Structures (ROPS). If any additional devices are installed that exceed the Max. certified weight indicated on ROPS name plate, the ROPS certification may be nullified. The protective structure of the cabin should be replaced immediately if it is permanently deformed or damaged.

Machines operated in areas where there is a risk of objects falling onto the cabin are fitted with a Falling Object Protective Structure (FOPS) pursuant to ISO 10262.

Fire and Explosion

Preventing fires

The following actions should be taken to minimize the risk of fire:

- Do a visual inspection before operating the machine to check for any risk of fire.
- Do not operate the machine if there is a risk of fire.
- Be sure to identify the primary exit and alternative exit of the machine, and fully understand how to use the exits in the event of a fire.
- Do not perform any welding or drilling work on the engine cover.
- Keep the engine compartment free from the build-up of flammable materials such as dead leaves, small branches, paper, and other types of trash.
- Keep the covers of the major parts of the machine closed. Make sure that the covers operate normally in order to be able to use firefighting equipment in the event of a fire.
- Be careful when handling fuel. Fuel is a highly flammable.
- Always stop the engine when refueling the machine.
- Remove any build-up of flammable materials from the machine.
- Do not operate the machine near a flame.
- All fuels and most lubricant and coolant mixtures are flammable materials, so special care should be exercised when handling such materials to prevent fire and explosion.
- Keep all fuels and lubricant in adequate containers.
- Never smoke in the area where refueling is taking place or in the space for handling battery electrolytes and other flammable materials.
- Oil leaked to a hot surface or electronic component may cause a fire.
- Do not operate the machine if there is an oil leak. Repair the source of the oil leak, and wipe clean any leaked oil before operating the machine.
- Keep the electric connectors clean at all times, and check the connections for signs of loosening at regular intervals.
- Do not weld, cut or use a cutting torch through any tubes or lines in which flammable flows. Check all tubes and lines for signs of abrasion or deterioration and replace if damaged.
- Dust or particles generated when repairing the non-metallic hood or fender are flammable or explosive. Repair such parts in a well ventilated area well away from flames or sparks, and be sure to wear suitable PPE (Personal Protective Equipment).



Preventing explosions

The following actions should be taken to minimize the risk of explosion:

- Never use starting aid fluid in a low-temperature environment as it can have an adverse effect on the engine performance and may cause an explosion.



- Do not attempt to charge a frozen battery. Forcibly charging a frozen battery may result in an explosion.
- Use caution when handling the batteries. Never let a tool make contact with the positive battery post and the frame of the machine simultaneously.

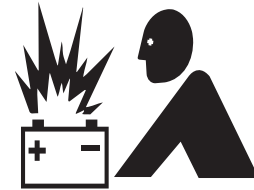

- Sparks may be generated, resulting in an explosion.
- Only charge the battery with a charger of equal voltage. Incorrect voltage may cause overheating and explosion.
- Do not use or charge the battery if the level of electrolytes in the battery is low.

Regularly check the electrolyte level, and refill with distilled water to the maximum level.

- Do not attempt to start the engine using an unsuitable booster cable as it may result in an explosion and serious injury or death.



Only use the booster cable to start the engine in a well ventilated open space. Starting the engine with a booster cable may generate flammable gas.

- When hydraulic equipment and piping are overheated, flammable gas or airborne particles may explode. Protect and insulate such parts to prevent overheating.

Corrective Actions Before and After a Fire

In the event of a fire in the machine, the top priority should be the safety of the operator and workers in the work area.

In the event of a fire at a level that does not endanger the operator or workers, the following actions should be taken:

- Move the machine well away from any flammable materials (e.g., fuel, engine oil, clothes, and bits of wood) and adjacent buildings.
- If the engine is running, it may cause a persistent fire. Immediately stop the engine.
- In the event of an electric short, disconnect the batteries to eliminate the main ignition source.

In the event of an electricity leak resulting from damage to the power wiring caused by fire, disconnect the batteries to eliminate the secondary ignition source.

If a fire becomes too large to control, assess the following risks:

- The tank, accumulator, hose and fitting may burst into flames, splashing fuel and scattering particles throughout the surrounding area.

If you have to handle a machine that has been damaged by fire or one that is exposed to excessively high heat after extinguishing a fire, take the following precautions:

- Wear thick protective gloves and protective goggles.
- Never touch any materials left after combustion with your bare hands.
- Avoid contact with melted polymer materials (e.g., plastics).

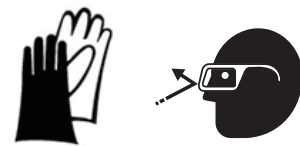

Information on fire extinguisher

Fire extinguishers (if equipped) should be kept in a fully operable condition, and be inspected by a qualified person on a regular basis. Workers should complete a training course on the use of fire extinguishers in advance.

Use fire extinguishers in accordance with the following procedures, if required:

- ① Pull the safety pin of the fire extinguisher first.
- ② Extend the nozzle, and stand toward the fire.
- ③ Aim the nozzle at the flames, and firmly press the top and bottom handles.
- ④ Stand in a downwind position, and evenly spray the foam over the flames.

If the weight of the fire extinguisher exceeds 4.5 kg, mount the extinguisher in a location near the bottom of the cabin. Do not mount the fire extinguisher at a level higher than one third of the height of the cabin.

Do not weld or drill ROPS to mount a fire extinguisher. Contact your dealer or distributor for more information about the correct mounting of fire extinguishers.











Health and Safety

Personal protective equipment

The wearing of personal protective gear is mandatory for protecting the human body from hazardous chemicals and hazardous environments.

The wearing of personal protective gear is a means of preventing injury, and should not interfere with the performance of jobs. It is designed to protect the human body from hazardous environments and hazardous materials, and should be kept in an easily accessible place.

List of personal protection gear

Name	Symbol	Remarks
Safety helmet		Protects the head from falling objects, and reduces risks when falling down.
Dust mask		Air-purifying dust mask should not be worn in workplaces with an oxygen concentration of less than 18%.
Gas mask		Prevents the inhalation of mist, airborne particles, or protects against the spray of hazardous chemicals.
Welding helmet		Blocks airborne dust and slag, and shields the face from bright light during welding.
Protective clothing		Blocks dust, mist and hazardous chemicals, and protects against burns.
Protective gloves		Electric insulation gloves: Should be worn when working in areas with a high risk of electric shock. Chemical protective gloves: Should be worn when working in areas where there is a risk of contact with hazardous chemicals including materials leaked from batteries.
Protective goggles		Protects the eyes from dust, particles and airborne materials in work areas.
Earplugs and earmuffs		Wear earplug and earmuffs separately or in combination depending on the level and duration of noise.
Safety shoes		Protects the feet from falling objects, impacts, and sharp objects.

Health and safety instructions in hazardous environments

Comply with the following instructions during operation and maintenance of the machine.

When handling oil

Failure to wear personal protection may result in burns caused by contact with a high-temperature liquid. Make sure you wear protective goggles, protective gloves and protective clothing when handling oils such as hydraulic oils and engine oil.

If the eyes come into contact with oil, wash them with a sufficient quantity of water for 15 minutes or longer. If the skin comes into contact with oil, take off contaminated clothes and shoes, and wash the skin with soap and water for 15 minutes or longer.



When handling the battery

If battery electrolyte leaks while handling the battery, the sulfuric acid contained in the electrolyte may cause burns. The lead components in battery electrolyte are toxic, so be sure to wear protective gloves and protective clothing. Always wash your hands after handling the battery.

If a part of your body not protected by personal protective equipment comes into direct contact with battery electrolyte, immediately wash the affected part with flowing water for 20 minutes or more, and then see a doctor without delay.

If you accidentally swallow battery electrolyte, drink water, do not forcibly induce vomiting, and immediately seek medical help.

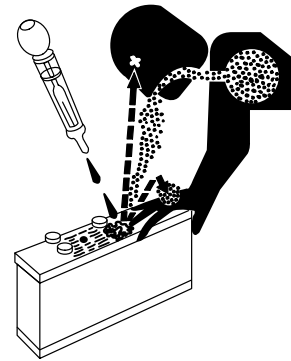

When handling refrigerant

Always wear protective goggles, protective gloves and other personal protective equipment when handling refrigerant to prevent direct contact of the skin with the refrigerant.

Wear protective gloves made of materials that are resistant to chemicals (such as neoprene and butyl rubber).

Never smoke when handling refrigerant.

If refrigerant comes into direct contact with the skin, wash the skin with warm water immediately.



When handling coolants

Do not remove the radiator cap after operation of the machine until the engine has cooled and the pressure has dropped to a safe level. Failure to comply may result in serious burns.

Coolant contains toxic and combustible ethylene glycol, and should be handled in a cool, well-ventilated place only when wearing protective goggles, protective gloves, protective clothing, and a gas mask.

Avoid inhaling airborne particles or spray from coolant. If the substances make contact with skin or eyes, immediately wash the skin and eye with flowing water for 20 minutes or longer.



When working in a place subject to airborne particles and falling objects,

Always wear a safety helmet, protective goggles and safety shoes to prevent injury from airborne particles and thrown or falling objects. Earplugs or earmuffs may be necessary when working in a noisy place.









When working in places with a high level of noise

When the operator is exposed to the noise exceeding 90 dB (A) for 8 hours or longer, wear earplugs or earmuffs.

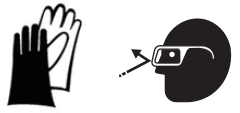

Personal protection gear for various situations

Situation	Symbol
Oil handling	
Battery handling	
Refrigerant handling	
Coolant handling	
Repair by welding	
Working in areas subject to airborne particles and falling objects	
Working in places with a high level of noise	
Handling machines damaged by fire or exposed to excessively high temperature	

WEAR PROTECTIVE CLOTHING

Wear close fitting clothing and safety equipment appropriate to the job.

- Do not wear loose clothing and accessories. Secure long hair. These items can snag on controls or on other parts of equipment.
- Do not wear oily clothes. They are highly flammable.
- Wear a hard hat, safety shoes, safety goggles, mask, leather gloves, earplugs and other protective equipment, as required.
- While working on machine, never use inadequate tools. They could break or slip, or they may not adequately perform intended.

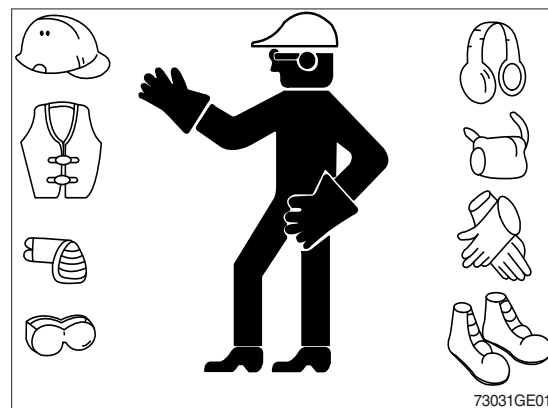

73031GE01

Noise and Vibration

Information on vibration

This part describes the vibration data of the machine, and methods of calculating the vibration level.

The vibration level of the machine varies according to any of the following conditions:

- Driving habits of the operator
- Quality of seat and suspension
- Type of machine, attachments, and conditions of machine
- Conditions of work site, working environment, ground surface conditions, and weather

Vibration also varies according to the duration of operation.

Physical Agents Directive 2002/44/EC defines the exposure action value as 0.5 m/s^2 , and the exposure limit value as 1.15 m/s^2 . If the predicted value is near the exposure action value or exposure limit value, the predicted value should be assumed to exceed the two latter values, and necessary action should be taken.

In regards to the actions taken according to the vibrations, refer to the following table:

Daily vibration exposure (A(8))	Vibration exposure range	Actions to be taken
$A(8) \leq 0.5 \text{ m/s}^2$	Exposure action value or lower	When approaching the exposure activity value, reasonable measures should be taken to minimize exposure to vibration. The relevant information and opportunities for training on vibration reduction should be provided to the operator.
$0.5 \text{ m/s}^2 < A(8) \leq 1.15 \text{ m/s}^2$	Exceeding the exposure action value, but not exceeding the exposure limit value	It is required to execute certain measures for reducing exposure to and risks of vibration to the minimum. The health of an operator who has been exposed to excessive vibration should be examined.
$1.15 \text{ m/s}^2 < A(8)$	Exceeding the exposure limit value:	Immediate action is required to reduce the vibration exposure level to below the exposure limit value.

※ For further information, please contact your local Hyundai dealer.

The vibration level can be predicted based on the information in the following table which is used to calculate the daily level of vibration exposure.

Predict the vibration level in the three vibration directions of axes X, Y, and Z. The mean vibration level should be used under normal operation conditions. Scenario factors from mean vibration level based on operation by skilled operator and on smooth terrain are excluded. Scenario factors are included to obtain the mean vibration level based on aggressive operation and severe terrain to assess the expected vibration level.

※ All vibration values are indicated in m/s^2 .

ISO Reference table - Vibration level equivalent to whole body vibration emission of the excavator (Unit : m/s^2)

Machine family	Machine kind	Typical operating condition	Vibration Levels			Scenario Factors		
			X axis	Y axis	Z axis	X axis	Y axis	Z axis
Excavator	Compact crawler excavator	Excavating	0.33	0.21	0.19	0.19	0.12	0.10
		Hydraulic breaker app.	0.49	0.28	0.36	0.20	0.13	0.17
		Transfer movement	0.45	0.39	0.62	0.17	0.18	0.28
	Crawler excavator	Excavating	0.44	0.27	0.30	0.24	0.16	0.17
		Hydraulic breaker app.	0.53	0.31	0.55	0.30	0.18	0.28
		Mining application	0.65	0.42	0.61	0.21	0.15	0.32
		Transfer movement	0.48	0.32	0.79	0.19	0.20	0.23
	Wheeled excavator	Excavating	0.52	0.35	0.29	0.26	0.22	0.13
		Transfer movement	0.41	0.53	0.61	0.12	0.20	0.19

Instructions on mitigating vibration

Machines should be correctly adjusted and maintained to ensure smooth operation. The terrain conditions should be observed. The following instructions will help reduce the whole body vibration level:

- ① Use the correct size attachments for your machine.
- ② Maintain the machines pursuant to the manufacturer's recommendations.
- ③ Maintain and provide good terrain conditions.
 - Remove any large rocks or obstacles.
 - Fill gutters or holes.
 - Adjust speed and driving path as needed for the conditions.
- ④ Use a driver's seat that satisfies ISO 7096.
 - Adjust the driver's seat and suspension for the weight and the size of the operator.
 - Inspect the suspension and adjusting devices of the driver's seat.
- ⑤ Perform the following maneuvers without using excessive force :
 - Steering
 - Braking
 - Accelerating
 - Gear shifting
- ⑥ Move the attachments smoothly.
- ⑦ Keep the level of vibration minimal when working for a long time or driving for a long distance.
 - Use a machine mounted with suspension system.
 - Transport the machine when moving between worksites; do not drive the machine to get to another worksite.
- ⑨ Take the following actions for optimal operator comfort and convenience:
 - Adjust the driver's seat adjustment device to allow a convenient posture.
 - Adjust the angles of the mirrors to minimize awkward, compromised posture
 - Avoid working for an excessively long time, and take regular breaks.
 - Do not jump on or off the cabin.
 - Minimize repeated handling of loads and lifting of loads.
 - The vibration information and calculation procedures are based on <ISO/TR 25398> has been defined according to the emission of vibrations measured under the actual working conditions of the machines.

Information on noise

Noise level (EN 474-1:2018 and 2000/14/EC) are as follows :

- Sound pressure level (LpA) : See pages 0-3.
- Sound power level (LwA) : See pages 0-3.

Emergency situations

In the event of an emergency situation, use the emergency hammer installed inside the cabin to break the windshield of the cabin, and carefully escape from the cabin. The emergency hammer should always be kept inside the cabin for emergencies, and should not be removed or used for other purposes. If the emergency hammer is lost, replace it immediately.

Keep a first-aid kit inside the cabin or in another place at the worksite for safety accidents.

Keep contact information (e.g., phone number) to request help with an emergency situation or injury.

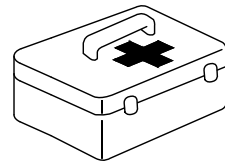
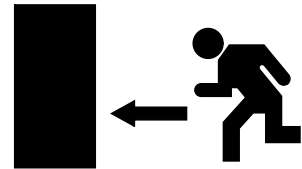

Safety Information on the Machines and Operation

Before Operating the Machine

Carefully examine the following conditions and take any necessary actions to prevent risk factors before operating the machine:

Checking the worksite

- Always be aware of weather conditions at your worksite. Fog or heavy rain may decrease visibility or render the machine inoperable. In the event of lightning, immediately put the bucket to the ground and evacuate to a safe place.
- Check the worksite for obstacles, and avoid collisions with such obstacles during operation. Check the surroundings of the machine for any obstacles that may hinder operation.
- Check the worksite for buried waterlines, telecommunication cables, power cables and oil pipelines in advance, and avoid damaging them.
- If the terrain of the worksite is too rough for normal operation of the machine, flatten the terrain before operating the machine. Make sure that the ground of the worksite is not soft as it may cause hazards during operation.
- If the worksite is a marshy place (e.g., shallow river, large or small lake, swamp, etc), check the conditions and the depth of marshy areas and the flow rate before driving or operating the machine. Do not operate the machine underwater.
- When operating the machine in water or when crossing shallow, check the bed soil condition and depth and flow speed of water, then proceed taking care that water is not above upper rollers.
- Do not operate the machine on cliffs or at the end of a road on soft ground as the machine may overturn. If operation of the machine on such terrain is unavoidable, keep the track perpendicular to the end, place the driving motor at the rear to facilitate escape from the machine in the event of an emergency situation.
- When operating the machine in areas with pedestrian or vehicle traffic, or in a zone in the vicinity of such an area, appoint workers exclusively responsible for controlling the traffic, or install fences or blocking wall to separate the worksite from the traffic area. Prevent unauthorized workers or machines from accessing the worksite.

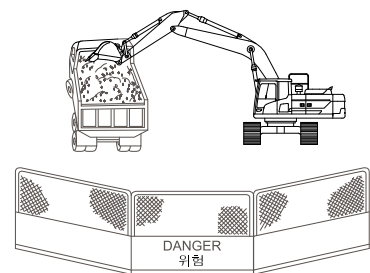
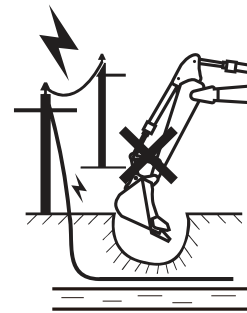

Instructions before operating the machine

- The machine shall be operated by authorized and skilled operators only.
- The operator should wear clothes and personal protection gear that are appropriate for the work environment.
- Do not operate the machine while under the influence of alcohol or drugs or while experiencing extreme fatigue or other conditions that may affect your awareness of your surroundings or your reaction time.
- The operator should read and fully understand the operator's manual before operating the machine.
- The operator should fully understand the details and procedures of the work to be performed.
- Do not perform work when a hazard is anticipated or encountered. Remove the hazard before beginning work. Failure to comply may result in serious injury or death.

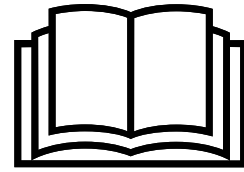

Inspect the machine before operating the machine

- Check the machine for abnormal noise, vibration or heat, and for the leakage of engine oil, hydraulic oil, fuel or refrigerant.
- Remove any foreign substances from the engine and the battery. The buildup of such substances may cause a fire.
- Do not operate a machine until any necessary repairs are completed.
- Do not operate the machine until all regular inspection and service recommended in the operator's manual have been executed.

- Adjust the operator's seat to suit the physical condition of the operator. Check the seatbelt for damage, and replace it if damaged. Do not store unnecessary objects or tools in the cabin.

- Keep clean all parts related to visibility, such as the windshield and rearview mirror. Adjust the rearview mirror to ensure that the operator's field of vision is clear.

- Check the acoustic alarms (e.g., the horn and warning signal when driving backward or moving) for normal operation.

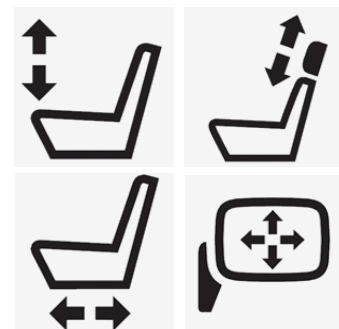

During Operation of the Machine

Getting on and off

- Do not jump on or off the machine.
 - Do not try to get on or off the machine while it is moving.
 - Get on or off the machine using the handrail and step (or stepladder, if any). Always keep the handrail and step clean and free from mud or oil.
 - Wear anti-slip shoes.
 - Comply with the principle of three-point contact* by contacting the machine with either both hands and one foot or vice versa when getting on or off the machine.
 - Do not sit on any part of the machine not intended for sitting.
- ※ **Three-point contact means making contact with the machine with both hands and one foot, or with one hand and both feet.**

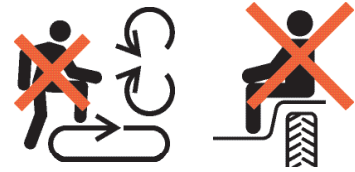

During operation

- The operator should start the engine only after sitting on the operator's seat. Make sure that all levers are shifted to the neutral position before starting the engine.
- Pay close to any obstacles when operating the machine, particularly when turning or moving backward, to prevent collision. Failure to comply may result in serious injury or death.
- Do not exceed the recommended size and weight of an object when lifting a load. Do not lift a heavy object with slings by suspending the slings on the tooth of the bucket.
- Do not allow anyone to stand under the bucket.

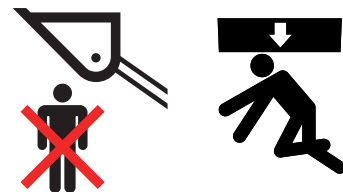
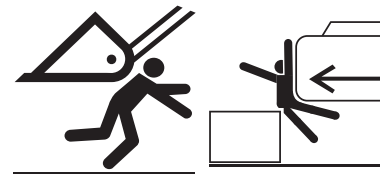

Operation on a slope

When operating the machine on a slope, failure to comply with these instructions could result in the machine tipping over, which may lead to serious injury or death.

- Do not work on slopes of 10° or more.
- Do not exceed the maximum climbing angle of 30°.
- If operation of the machine on a slope is unavoidable, perform the work after flattening the ground.
- When operating the machine laterally on a slope, there is a high risk of machine overturning or slipping. Do not operate the machine in such conditions.
- Do not operate the machine on a slope covered with wet grass or a thick layer of dead leaves, as the machine may slip.
- Do not park or stop the machine on a slope. If parking or stopping the machine on a slope is unavoidable, bring the bucket down to the ground, and support the wheels with wheel chocks.

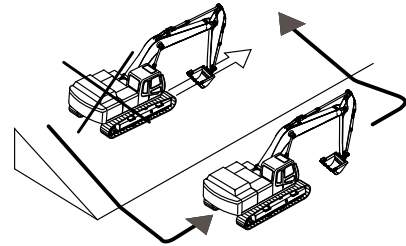
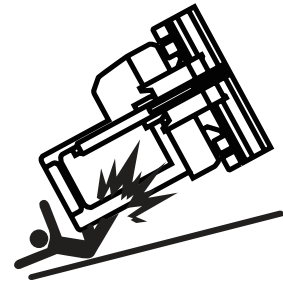

- When traveling up a slope, operate the machine at a slow speed with the attachment extended forward to keep the machine balanced, and with the bucket raised at least 20~30 cm (1 ft) from the ground.
- When traveling down a slope, reduce the engine speed with the travel lever kept in the vicinity of the neutral position. Keep the bucket 20~30 cm (1 ft) above the ground, and use the bucket as a brake in an emergency situation.
- If the engine suddenly stalls, immediately bring the bucket to the ground.
- If the fuel gauge reaches the red zone while operating the machine, immediately refill with fuel. (If the machine operates on a slope under these conditions, air may be introduced into the engine, causing it to stall suddenly.)

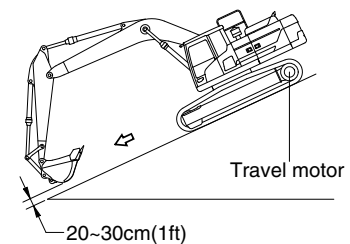
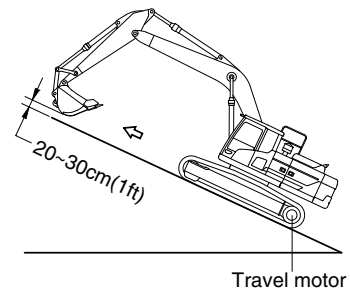

Operations to be avoided or prohibited

- Pay attention when operating the machine in an enclosed space as this may result in the risk of a buildup of hazardous gases.



- If the machine is operated in the vicinity of a high-voltage line, there is a risk of death or serious injury.
- Be aware of the height and working radius of the machine, and maintain the minimum safety distance.

Voltage	Minimum safety distance
6.6 kV	3 m (10 ft)
33.0 kV	4 m (13 ft)
66.0 kV	5 m (16 ft)
154.0 kV	8 m (26 ft)
275.0 kV	10 m (33 ft)

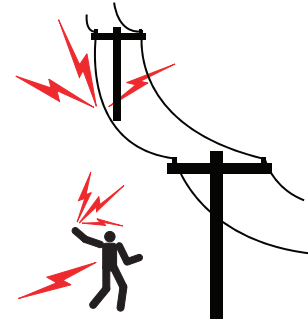

- In the event of contact with a high-voltage line, keep sitting on the operator's seat until the electric current has been shut down.
- Warn any workers on the ground in the vicinity of the machine not to make contact with the machine.
- If leaving the machine is unavoidable, jump down to a place free from any contact with the machine.



- Avoid operating the machine on soft ground, a slope or cliff as there is a risk that it may overturn. Pay special attention when it is raining as the rainfall may soften the ground.
- When operating or driving the machine in water, check the floor conditions, depth of water and flow rate, and make sure that the top roller and axle housing are not immersed in water.
- Do not operate the machine under adverse weather conditions caused by overcast skies, snow and rainfall.
- Do not turn or travel with the machine when the bucket is stuck in the ground.

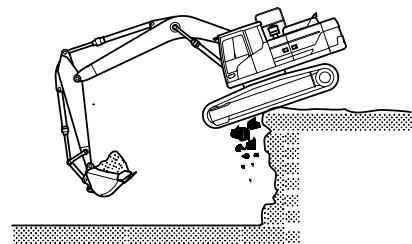

Cautions when operating in specific areas

Operating in extremely cold environments

- Do not attempt to start, stop or turn the machine suddenly as this may cause it to slip. There is potential for the machine to slip.
- Snow-covered or frozen ground may be slippery and dangerous.
- Idle operation of the machine may be required to elevate the engine temperature during startup.
- An impact resulting from a sudden movement of the boom or the attachments at an extremely low temperature may cause serious damage to the machine.
- The working cycle or loading weight might be reduced to lower than those under normal conditions.
- Follow these instructions when operation in cold environments:
 - Warm up the engine for 3~4 seconds when starting up the engine.
 - Always fully charge the battery. A discharged battery will freeze earlier than a fully charged battery.
 - Use engine oil and fuel that are appropriate for the temperature.
 - Keep the fuel tank full.
 - Remove any moisture from the fuel tank, and change the fuel filter regularly.
 - If the fuel filter is frozen, the flow of fuel may be blocked.
 - Pour the proper volume of antifreeze into the coolant.
 - Wait until the various parts of the machine reach the operating temperature after starting the engine.
 - Make sure that every controller and function of the machine operates normally.
 - Remove any dirt, snow and ice from the machine after completing the operation.

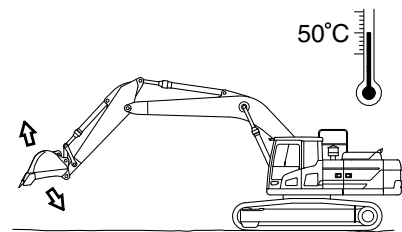

Operating in extremely hot environments

- Continuous operation of the machine for a long period of time may cause the machine to overheat. Pay special attention to prevent overheating of parts such as the engine and the hydraulic system. Stop the machine and take a break if necessary.
- Check the following conditions frequently:
- Check the level of the coolant in the radiator.
 - Check the radiator grill for clogging by any debris, and remove them, if any.
 - Check the level of the battery electrolyte.
 - If the battery will not be used for a long period of time, store it in a cool place.
 - Check the hydraulic system for oil leakage.
 - Check the lubrication oil on the respective parts, and lubricate as needed.
 - If the paint coating of any parts has been effaced or damaged, coat the parts with paints or treat them with an anti-rust additive.
 - Do not park the machine under direct light for a long period of time.
 - When parking or storing the machine outdoors, use the proper cover to protect the machine from sunlight and dust.

Operating in dusty or sandy environments

- Check the radiator grill for clogging by any debris, and remove any debris.
- Check the fuel system, and protect it from dust or sand when refueling.
- Inspect the air cleaner regularly, and replace it if necessary.
- If the gauge lamp on the dashboard lights up and the buzzer sounds at the same time, clean or replace the air cleaner.
- Frequently check consumables such as hydraulic oil and lubrication oil, and change them if necessary. Protect against the introduction of dust or sand when changing the consumables.
- Check the air-conditioner and the heater filters regularly, and clean or replace them if necessary.
- When parking or storing the machine outdoors, use the proper cover to protect the machine from dust and sand.

Operating in rainy or humid environments

- Do not operate the machine in areas where there is heavy rainfall or thick fog.
- If operating the machine in such areas is unavoidable, perform operation after ensuring sufficient field of vision.
 - Use lighting devices such as the head lamp and working light.
 - Warn any workers within the radius of operation of the machine.
- Pay attention when operating the machine on smooth ground as there is a risk of it overturning.
- If the paint coating on any parts has been effaced or damaged, coat the parts with paint or treat them with an anti-rust additive.

Operating the machine in coastal areas

- Special care should be taken when operating the machine in coastal areas as exposed parts may be corroded easily.
- If the paint coating on any parts has been effaced or damaged, coat the parts with paint or treat them with an anti-rust additive.
- Perform inspection and maintenance of the parts promptly.

Cautions during maintenance

Tools

- Use the correct tools for each type of work.
- Using improper tools may damage the machine and its parts.
- Using deteriorated or damaged tools may result in bodily injury.



Inspection and servicing

- Prevent access to the machine by all unauthorized workers.
- Prior to inspection, park the machine in a flat area and attach a 'Under Inspection' sign.
- Clean the machine before inspection or maintenance.
 - When performing inspection or maintenance on a dirty machine, it may be difficult to diagnosis or detect the cause of a problem with the machine.
 - Dust or dirt accumulated on the machine may cause a worker to slip or fall.
 - Wear protective goggles and protective clothes when cleaning the machine using a compressed water.
 - Do not spray water or steam directly onto any electronic components.
- Use proper lighting devices when operating the machine in a dark area.
- Use lighting devices that are explosion-proof when handling flammable materials such as fuel and hydraulic oil.
- Never attempt to use a direct flame such as a cigarette lighter in lieu of the lighting device.

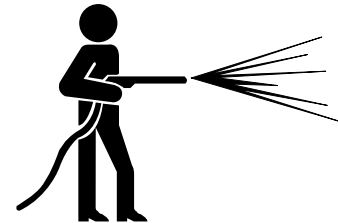

- Check the level of the cooling water after stopping and sufficiently cooling down the engine.
- Sufficiently relieve the inside pressure before opening the cooling water cap.
- The cooling system contains basic components. Use caution to prevent the skin or eyes from coming into contact with the basic materials.
- Exercise special care to protect the body from contact with hot fluid or parts.
- Replace the filters only after shutting off and sufficiently cooling down the engine.
- Slowly remove the operating oil filter plug to relieve the inside pressure.
- Relieve the pressure from the hydraulic system before disconnecting any lines and fittings.



Collision or cutting

- Never perform a maintenance while the engine is running.
- Never open or remove the engine hood while the machine is in operation.
- If an inspection is required while the engine is running, two or more workers must perform the inspection.
- Keep areas in the vicinity of rotating or moving parts clean.
- Keep articles in the vicinity of the fan clean.
 - Wear safety gloves when handling the wire cables.
 - Wear protective goggles and protective clothes

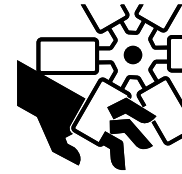
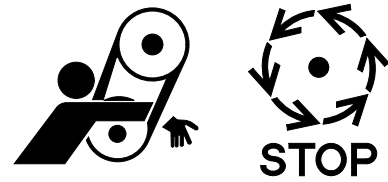

Preventing fire and explosion

- Use caution when handling fuels, lubrication oils, and coolant mixtures to prevent fire and explosion. Failure to comply may result in serious injury or death.
- Oil that leaks on to a hot surface or electronic components may cause a fire.
- Keep all fuels and lubrication oils in adequate containers.
- Do not smoke while refueling or while adding any fluids to the machine. Do not smoke near the fuel tank at anytime.
- Do not smoke in a space where battery electrolyte and other flammable materials are handled.
- Keep the electric connectors clean, and check the connections for signs of loosening at regular intervals.
- Do not weld or cut pipes or tubes through which gas or flammable fluid flows.

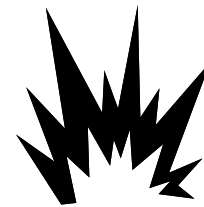

Cautions on decoupling the attachments

- Do not allow unauthorized workers to access the machine.
- Place the machine in a safe position.
- Install safety fences around the machine.

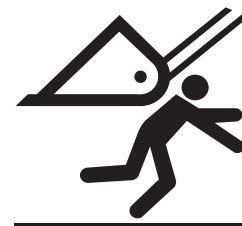

Repair by welding

- Only weld in an area where adequate facilities for welding are available.
- Welding work may be subject to risks of gas leak, flame and electric shock.

Welding should be performed only by a qualified welder.

- Take the following precautions when welding to avoid serious injury or death:
 - Separate and remove the battery to prevent battery explosion.
 - Perform direct heating in a place free from the risk of explosion.
 - Cover parts such as rubber hoses subject to damage by welding with flame-resistant materials.
 - Wear a welding helmet, protective clothes, protective gloves, and safety shoes.
 - Perform welding work in a well-ventilated place.
 - Remove all inflammable materials from areas in the vicinity of welding work.
 - Provide fire extinguishers.



Precautions to take when working on the machine

- There is a risk of falling when working on the machine.
- Keep the area around the workers' feet clean and tidy.
- Do not spill oil or grease.
- Do not leave tools lying on the floor.
- Be careful on the floor when moving.
- Never jump from the machine.
- When getting off the machine, use the step or handrail and get off the machine while keeping to the principle of three-point contact.
- Wear protective clothes if necessary.
- Do not perform maintenance work in an area where no anti-slipping pads have been installed.
- Replace anti-slipping pads and step treads with new ones if they have deteriorated or no longer function.

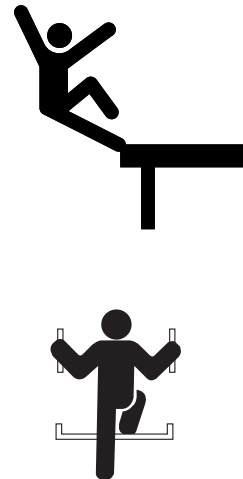

Cautions when working with the high-pressure line or hose

- Make sure that the internal pressure is released before replacing or checking the high-pressure line or hose.
- If the internal pressure is not released, serious injury may result.
- Take the following precautions to avoid serious injury or death:
 - Always check to make sure a working fire extinguisher is nearby
 - Leaked oil may penetrate the skin or cause serious injury.
 - Never check for oil leaks with your bare hands.
 - Check an oil leak using a wooden plate or cardboard.
 - Never bend or hit the high-pressure line hard.
 - Do not install a bent or damaged line or hose.
 - Make sure that all of the clamps and protective devices are properly installed.
- Check the pipes and hoses regularly and replace any damaged parts if necessary.

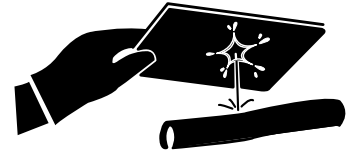

Cautions on inspecting the counterweight

- Failure to comply with these instructions may lead to serious injury or death.
- Never stand beneath the counterweight when installing or removing it.
- Make sure the condition of the lifting device is rated for the weight being lifted.
- Make sure lifting device is in good working order and free of damage or defects.



Battery

- The battery contains flammable materials.
 - Never smoke in the vicinity of the battery.
 - The battery electrolyte is strong acid. Pay attention to prevent the skin and eyes from coming into contact with the electrolyte.
 - If the battery electrolyte accidentally comes into contact with the body or clothes, immediately wash off the electrolyte with water.
 - If the battery electrolyte is frozen, do not use other devices to start the engine up.
 - Always wear protective goggles and protective gloves when working on the battery.
 - Always keep the switch in the 'OFF' position when working on the battery.
 - Securely fasten the battery cap.
 - Always disconnect the battery from the machine before charging the battery.
 - Disconnect the cathode (-) first when removing the battery.
 - Connect the anode (+) first when connecting the battery.
 - Follow the safety procedures when jump starting or charging the battery. Improper connection of the cable may result in an explosion and serious injury.
 - Use a voltmeter when inspecting the charging system.
 - Regularly inspect the battery cable, and replace it if damaged.
 - A battery cable with exposed wires may cause a short if it comes into contact with the grounding surface.
 - A short circuit of the battery cable may cause heat from the battery current and result in a fire.
 - If the wires of the ground cable are exposed between the battery and the master switch, the exposed wires make contact with the grounding surface and the current may bypass to the master switch. This may destabilize the machine operation.
- Repair or replace the part before operating the machine.

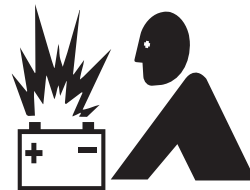
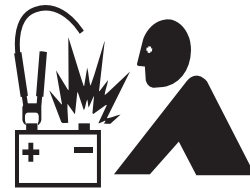

Parking and Storage

Cautions on parking

- Park the machine on flat ground.
- If parking the machine on a slope is unavoidable, use wheel chocks to prevent the machine from moving.
- Bring the bucket down and make firm contact with ground.
- Make sure that all of the switches are turned to the 'OFF' position.
- Do not turn off battery disconnect until led lamp at the disconnect goes off.
- Make sure that all of the controllers are turned to the neutral position.
- Stop the engine, and withdraw the ignition key.
- Close and lock the windshield, door and all covers.
- Install fences around the machine when parking it on a public road, and put up a warning sign.

Cautions on storage for a long period of time

- Park the machine in accordance to any state and local laws.
- When storing the machine for a month or longer, follow these instructions to prevent deterioration of the machine performance :
 - Thoroughly clean the machine before storing.
 - Inject sufficient lubrication oil and grease into the injection ports.
 - If any of the machines fluids are low top them off. If any fluids are close to or in need of changing, do so before storing.
 - Oils and coolant may deteriorate during storage based on the length of storage. Please take this into consideration before using the machine.
 - The density of the oil may drop during storage.
 - Apply an anti-rust additive to the exposed area of the piston rod of the cylinder in areas where it is likely to rust quickly.
 - Keep the master switch mounted in the power box (or the toolbox on the left of the rear frame of the machine) turned 'OFF'.
 - Keep the machine in a dry indoor environment.
If storing the machine outdoors is unavoidable, store it on a wooden pallet.
 - Keep all cylinders collapse so that the cylinder rods are not exposed.
 - Bring the attachments right down to the ground, and keep the tracks immobile by placing wheel chocks.

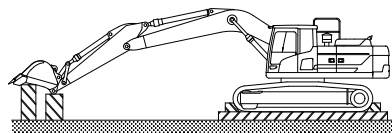

Regular lubrication (during storage)

- Breaking the lubrication film on parts may cause abnormal abrasion during the next operation.
- Check the level of the engine oil and coolant when starting the engine up, and top them up if necessary.
- Thoroughly wipe off any oil from cylinder rod before operating machine as it will attract dust and debris.
- Start up the engine once a month, perform all functions. Operate machine utilizing all functions for a minimum of 15 minutes. Apply lubrication oil to every part.
- Fully charge and store the battery.
- If storing the excavator for longer than 6 months, disconnect the battery negative (-) terminal.

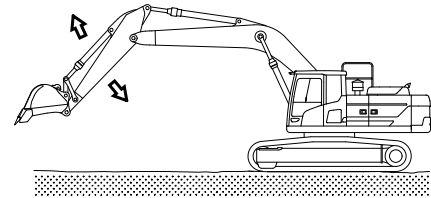
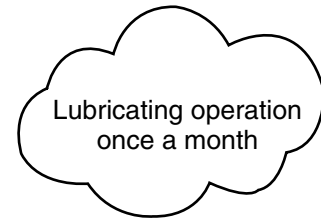

SAFETY LABELS

1. LOCATION

Always keep these labels clean. If they are lost or damaged, replace them with a new label.

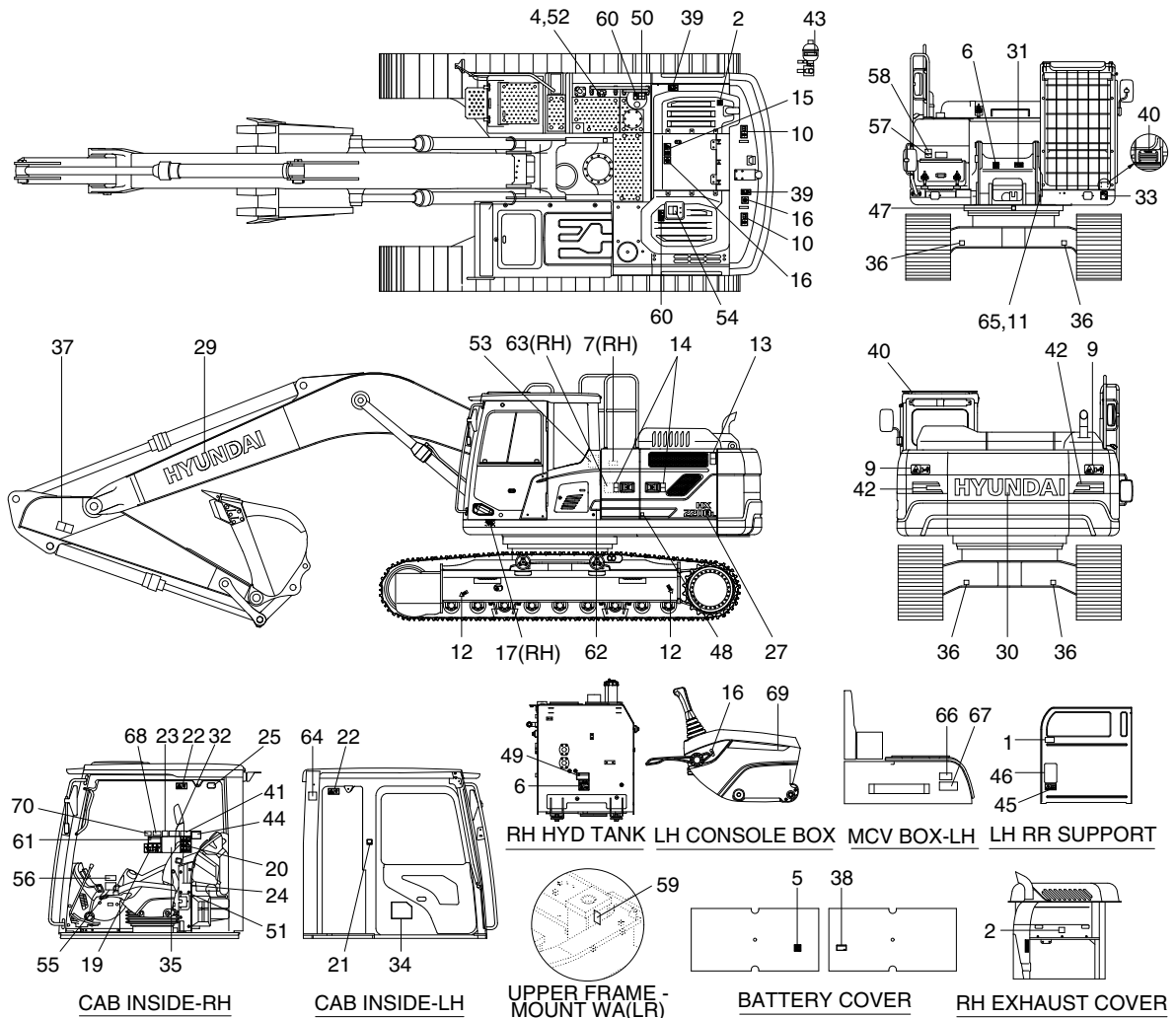

- | | | |
|-------------------------------|--|----------------------------|
| 1 Air cleaner filter | 27 Model name | 50 Fuel shut off |
| 2 Turbocharger cover | 29 Trade mark (boom) | 51 MCU/ECM connector |
| 4 Fueling | 30 Trade mark (CWT) | 52 Ultra low sulfur diesel |
| 5 Battery accident | 31 Reduction gear grease | 53 Cummins |
| 7 Hydraulic oil level | 32 Clamp locking | 54 Surge tank |
| 9 Keep clear-rear | 33 Noise level LWA | 55 Key off caution |
| 10 Lifting eye | 34 Service instruction | 56 RCV lever |
| 11 Name plate | 35 Lifting chart | 57 Diesel exhaust fluid |
| 12 Slings ideogram | 36 Tie | 58 DEF/AdBlue® tank |
| 13 Keep clear-side | 37 Keep clear-attachment | 59 Refrigerant |
| 14 Stay fix | 38 Electric welding | 60 High pressure |
| 15 Engine hood shearing | 39 Falling | 61 RCV control |
| 16 No step | 40 FOPS FOG plate | 62 Band |
| 17 Transporting | 41 Caution (water separator, turbocharger) | 63 Bio oil |
| 19 M/control pattern | 42 Reflecting | 64 Fire extinguisher |
| 20 Refer to operator's manual | 43 Accumulator | 65 EMC |
| 21 Hammer | 44 M/control pattern change valve | 66 Leftover fuel |
| 22 Safety front window | 45 M/control pattern change-w/o valve | 67 Air compressor |
| 23 Safety rear window | 46 M/control pattern change-w/valve | 68 Air compressor cab |
| 24 Air conditioner filter | 47 Swing bearing grease | 69 Console logo |
| 25 ROPS plate | 48 Battery position | 70 Proposition 65 |
| 26 Safety knob | 49 Lubrication oil (old) | |

90K6-00400

2. DESCRIPTION

There are labels on this machine. Ensure you are familiar with all labels before operating the machine.

Replace any label that is damaged or missing. If a label is attached to a part that is replaced, install a label on the replacement part.

1) AIR CLEANER FILTER (item 1)

This label is positioned on the left side of the front support.

- ※ **Periodic and proper inspection, cleaning and change of elements prolong engine life and maintains good engine performance.**

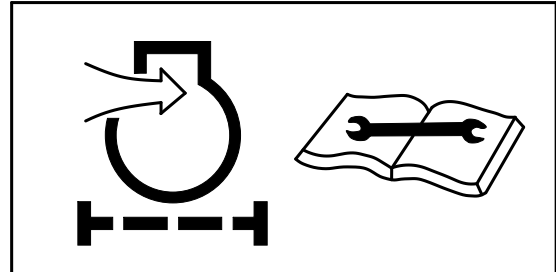

21070FW01

2) TURBOCHARGER COVER (item 2)

This label is positioned on the RH exhaust cover and turbocharger cover.

- ⚠ **Do not touch turbocharger or it may cause severe burn, while the engine is running or immediately after the engine is shut down.**

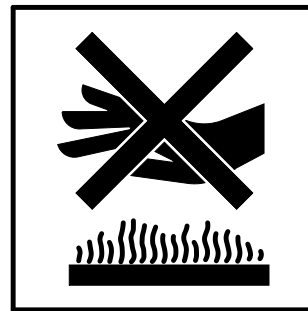

21070FW02

3) FUELING (item 4)

This label is positioned on the right side of fuel filler neck.

- ⚠ **Stop the engine when refueling. Any lights or flames must be kept at a safe distance while refueling.**

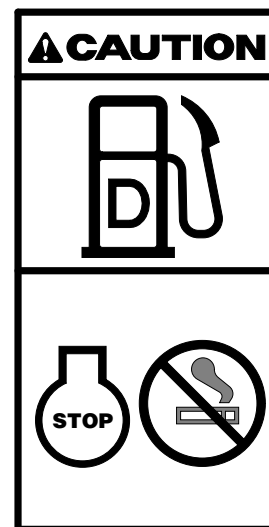

290F0FW02

4) BATTERY ACCIDENT (item 5)

This label is positioned on the battery cover. Follow all warnings. Failure to comply may result in serious injury or death.

▲ Electrolyte containing sulfuric acid can cause severe burns. Avoid allowing contact with the skin, eyes or clothes. In the event of accident flush with sufficient water and contact a physician immediately. Failure to comply may result in serious injury or death.

※ Maintain the electrolyte at the recommended level. Add distilled water to the battery only when starting up, never when shutting down.

With electrolyte at proper level, less space may cause the gases to be accumulated in the battery.

▲ Do not allow any open flames or excessive heat near or when checking the battery.

▲ Do not allow unauthorized personnel to change the battery or to use booster cables.

▲ To prevent electric shock, do not touch battery terminal with wet hands.

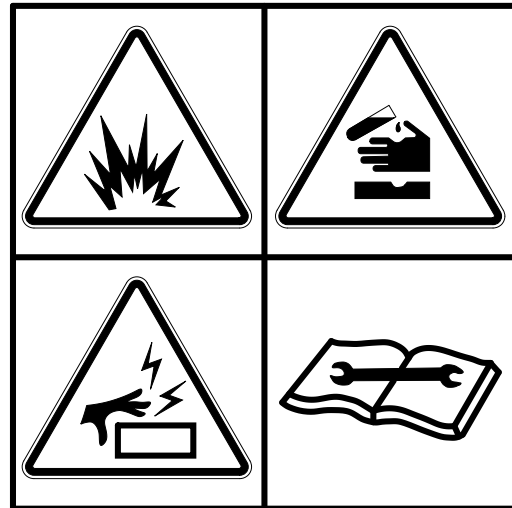

36070FW05

5) HIGH PRESSURE HOSE (item 6)

This label is positioned on the right side of the hydraulic tank and front side of the upper frame. Follow all warnings. Failure to comply may result in serious injury or death.

▲ Escaping fluid under pressure can penetrate the skin causing serious injury or death.

▲ Relieve all pressure before disconnecting any hydraulic, coolant or fuel lines etc.

※ See the maintenance section for details.



14070FW29

6) HYDRAULIC OIL LEVEL (item 7)

This label is positioned on the side cover of the RH cowl.

- ▲ Place the bucket on the ground whenever servicing the hydraulic system.
- ※ Check oil level on the level gauge as shown in the upper right hand illustration.
- ※ Using the recommend hydraulic oil, fill to the specified level if necessary. Please refer to section, Maintenance.

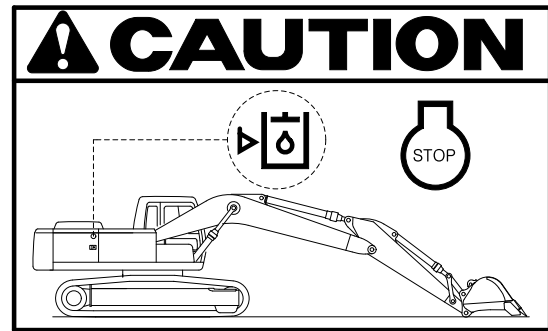

21070FW07

7) KEEP CLEAR-REAR (item 9)

This label is positioned on the both sides of the counterweight.

- ▲ To prevent serious personal injury or death keep clear of machine swing radius.
- ▲ Do not deface or remove this label from the machine.

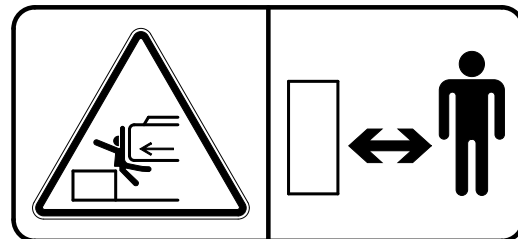

21090FW09

8) LIFTING EYE (item 10)

This label is positioned on the left and right upper sides of the counterweight.

- ▲ Do not lift the machine by using lifting eyes on the counterweight or the lifting eyes may be subject to break causing serious injury or death.
- ※ See page 5-11 for proper lifting method of the machine.

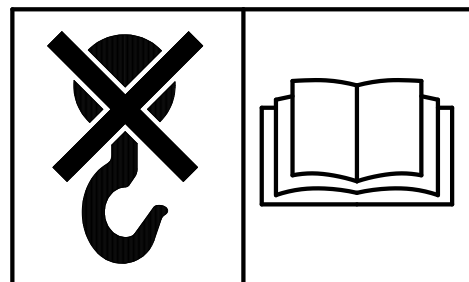

21070FW10

9) KEEP CLEAR-SIDE (item 13)

This label is positioned on the side cover of the LH and RH cowl.

- ▲ To prevent serious personal injury or death keep clear of machine swing radius.
- ▲ Do not deface or remove this label from the machine.



21070FW13

10) **STAY FIX** (item 14)

This label is positioned on the side cover of the LH and RH cowl.

- ⚠ **Be sure to fix the stay when the door needs to be opened.**
- ⚠ **A door which is not fixed in the fully closed or open position (via stay) can suddenly move causing severe personal injury or death.**

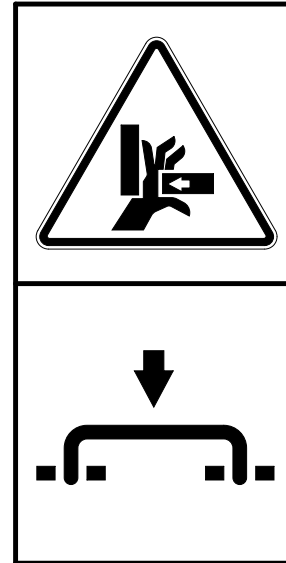

21070FW14

11) **ENGINE HOOD SHEARING** (item 15)

This label is positioned on the engine hood.

- ⚠ **Do not open the engine hood while the engine is running. Stay clear of rotating parts. Failure to comply may cause serious injury or death.**
- ⚠ **Do not touch exhaust pipe or it may cause severe burn.**

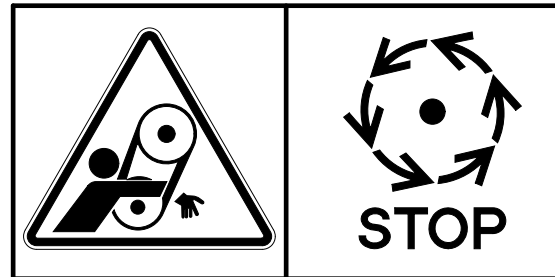

21070FW15

12) **NO STEP** (item 16)

This label is positioned on the engine hood and counterweight.

- ⚠ **Don't step on the engine hood and counterweight.**

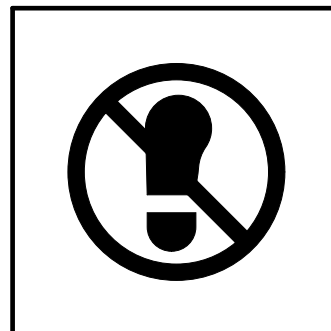

21070FW16

13) TRANSPORTING (item 17)

This label is positioned on the right side of upper frame.

- ▲ Review the operator's manual before transporting the machine. Tie down arm and track to the carrier with appropriate rated straps or chains.
- ▲ Be sure to protect machine from damage when strapping by using appropriate material such as wood, cardboard etc. See page 5-8 for details.

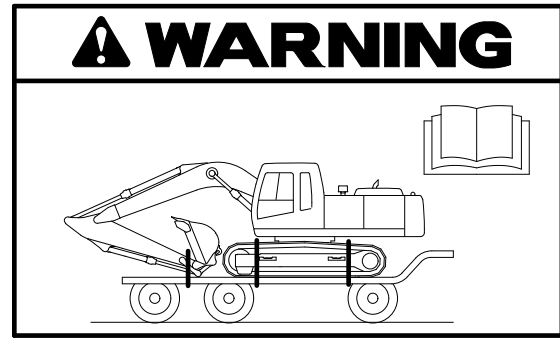

14070FW17

14) MACHINE CONTROL PATTERN (item 19)

This label is positioned on the right window of inside the cab.

- ▲ Always ensure the label matches the control pattern. If it does not, replace label with appropriate control pattern label.
- ▲ Failure to do so could result in serious injury or death. See page 2-12 for details.

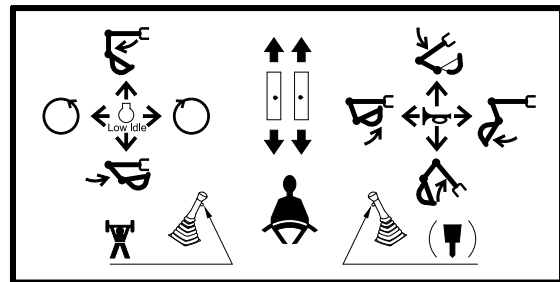

36070FW19

15) REFER TO OPERATOR'S MANUAL (item 20)

This label is positioned on the right window of inside the cab.

- ▲ Review the operator's manual before starting and operating machine.
- ▲ Do not operate this machine unless you have read and understand the instructions and warnings in this manual. Failure to follow the instructions or warnings could result in serious injury or death.

(1) Max height

- ▲ Serious injury or death can result from contact with electric lines. It is possible to receive shock by merely coming into the vicinity of electric lines, the minimum distance based on supply voltage should never be exceeded. Refer to page 1-21.

(2) Interference

- ▲ When operating machine equipped with quick clamp or extensions, the bucket may come into contact with the boom, boom cylinders or cab, during the bucket or arm retraction operation.

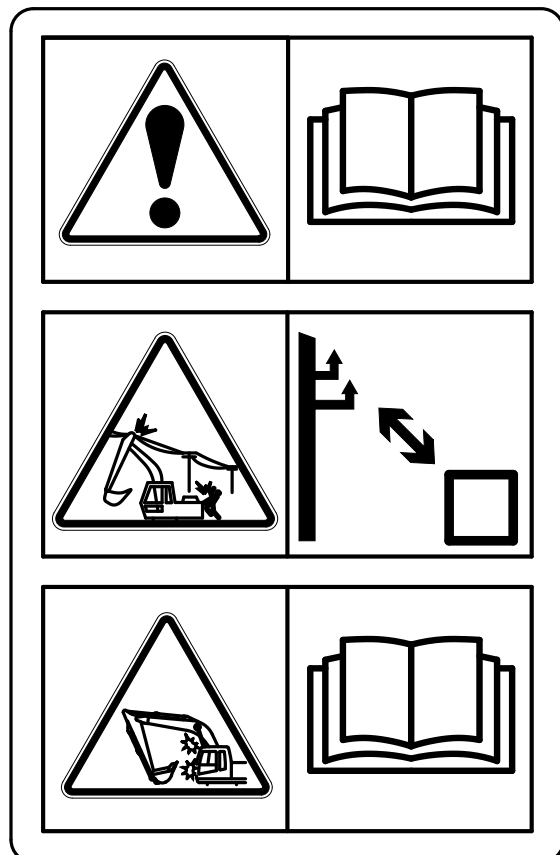

2609A0SL05

16) HAMMER (item 21)

This label is located inside the cab, on the center stay.

- ※ The window serves as an alternate exit.
- ※ In emergency, break out the window using the hammer and escape from the cabin.



91Q6-07280

17) SAFETY FRONT WINDOW (item 22)

This label is positioned on the LH and RH upper window of the cab.

- ▲ Make sure that front window is fully latched and locked into place before operating the machine. Failure to comply may result in serious injury or death.
- ※ See page 3-80 for details.

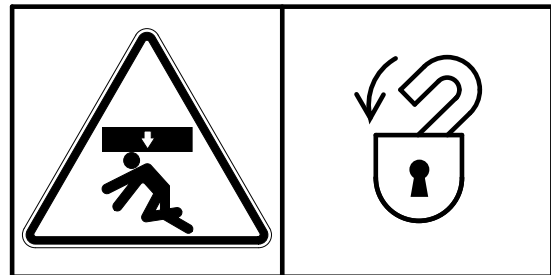

21070FW24

18) SAFETY REAR WINDOW (item 23)

This label is positioned on the right window of inside the cab.

- ※ The rear window serves as an alternate exit.
- ※ To remove rear window, pull the ring and push out the glass.

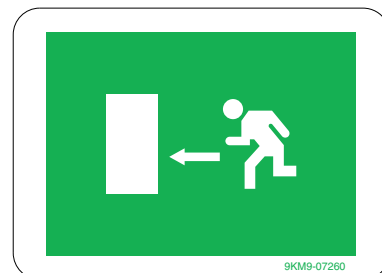

9KM9-07260

19) AIR CONDITIONER FILTER (item 24)

This label is positioned on the air conditioner cover.

- ※ Periodic and proper inspection, cleaning and change of filter prolong air conditioner life and maintain good performance.

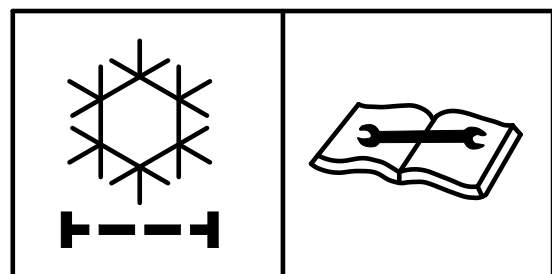

21070FW26

20) SAFETY KNOB (item 26)

This label is positioned on the cover of the safety knob, on the left side operators console.

- ▲ Before you get off the machine be sure to place the safety knob in the LOCKED position.
- ※ See page 3-47 for detail.

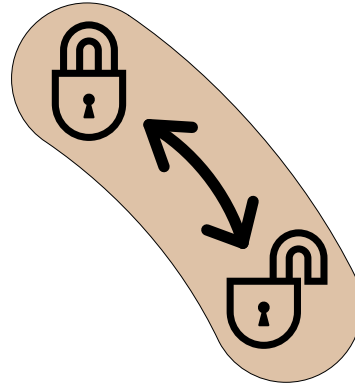

30007A1FW07A

21) REDUCTION GEAR GREASE (item 31)

This label is positioned in the front side of upper frame.

- ▲ Grease is under high pressure. Grease coming out of the grease plug under pressure can penetrate the body causing serious injury or death.

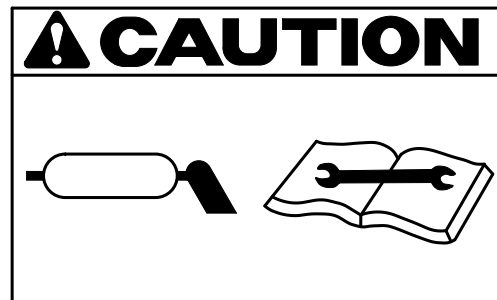

21070FW35

22) CLAMP LOCKING (item 32)

This label is positioned on the right window of inside the cab.

- ▲ Serious injury or death can result from a falling bucket.
- ▲ Operating the machine with quick clamp switch unlocked or without safety pin of moving hook can cause the bucket to fall off.

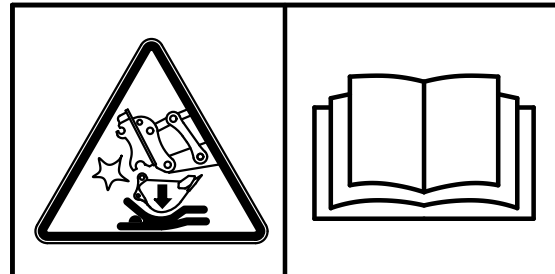

14070FW60

23) TIE (item 36)

This label is positioned on the front and rear of the lower frame.

- ▲ Never tow the machine using tie down eyelet as it may break resulting in personal injury or death.
- ※ See page 2-15 for detail.

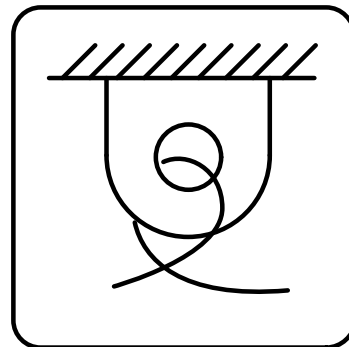

4507A0FW02

24) KEEP CLEAR-ATTACHMENT (item 37)

This label is positioned on both sides of the arm.

- ▲ **Serious injury or death can result from a falling attachment.**
- ▲ **To prevent serious injury or death, do not walk near, under implements or attachments. This applies when machine is in use, the implements are suspended in air or while the machine is being worked on.**

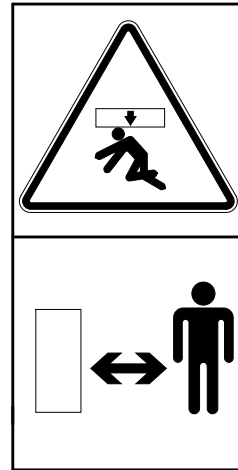

14070FW31

25) ELECTRIC WELDING (item 38)

This label is positioned on the battery cover.

- ▲ **Before carrying out any electric welding on this machine, follow the below procedure.**
 - Pull the connectors out of all electric control units.
 - Connect the ground lead of the welding equipment as close to the welding point as possible.
- ※ **Be sure to remove paint where ground will be applied to ensure proper grounding of welder. Once welding is complete, clean and repaint area.**
- ※ **See page 4-53 for detail.**

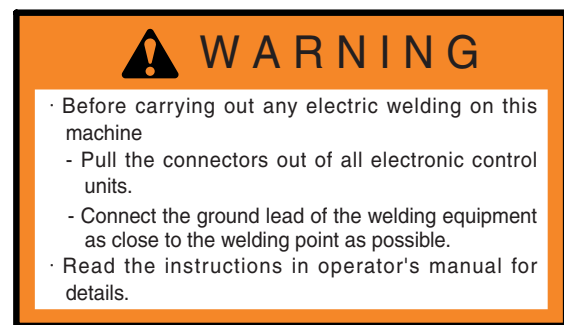

7807AFW20

26) FALLING (item 39)

This label is positioned on the top side of turbocharger cover and counterweight.

- ▲ **Falling from machine is one of the major causes of personal injury or death.**
- ▲ **Be careful of slippery conditions on the platforms, steps and handrails when standing on the machine.**

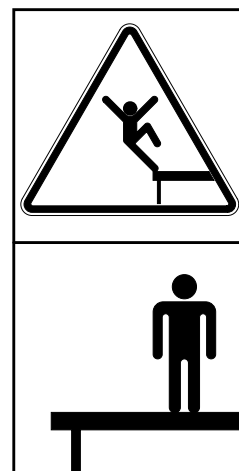

14070FW30

27) CAUTION (W/SEPARATOR, TURBOCHARGER) (item 41)

This label is positioned on the right window of inside the cab.

- ▲ In order to protect high pressure fuel system, please drain water in water separator before starting the engine.
- ▲ In order to prevent turbocharger failure, please allow more than 5 minutes cool down period (no load low idle operation) before shutting the engine off.

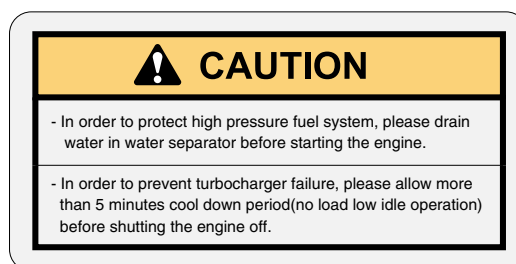

120090SL02

28) REFLECTING (item 42)

This label is positioned on the rear side of the counterweight.

- ▲ To prevent serious personal injury or death keep clear of machine swing radius.
- ▲ Do not deface or remove this label from the machine.



290F0FW01

29) ACCUMULATOR (item 43)

This label is positioned on the accumulator of the solenoid valve.

- ※ The accumulator is filled with high-pressure nitrogen gas, and it is extremely dangerous if it is handled in the wrong way. Always observe the following precautions.
- ▲ Never make any holes in the accumulator or expose it to open flame or fire.
- ▲ Do not weld anything to the accumulator.
- ※ When carrying out disassembly or maintenance of the accumulator, or when disposing of the accumulator. It is necessary to release the gas from the accumulator. A special air bleed valve is necessary for this operation, so please contact your Hyundai distributor.

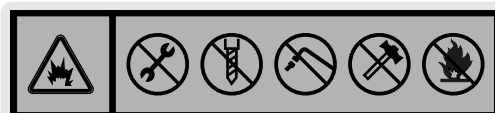

1107A0FW46

30) MACHINE CONTROL PATTERN CHANGE VALVE (item 44)

This label is positioned on the right window of inside the cab.

- ▲ **The machine control pattern can easily be changed to the "ISO type" or to the "A type" by changing the position of the lever-pattern.**
- ▲ **Before starting this machine, check the lever pattern change valve.**
- ※ See page 2-27 for detail.

2 PATTERN CHANGE VALVE

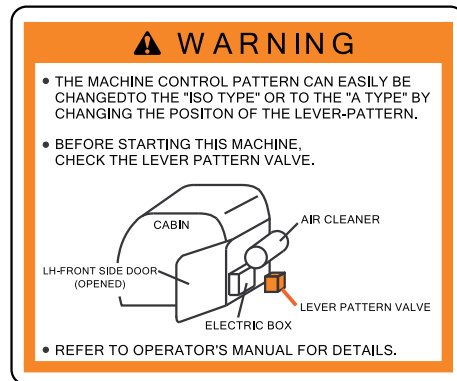

91N6-07400

31) MACHINE CONTROL PATTERN CHANGE-W/O VALVE (item 45)

This label is positioned on the LH middle support of cowl.

- ▲ **Check the machine control pattern before starting this machine.**
- ※ See page 2-26 for detail.



14W90FW47

32) MACHINE CONTROL PATTERN CHANGE-W/VALVE (item 46)

This label is positioned on the LH middle support of cowl.

- ▲ **Check the machine control pattern for conformance to the pattern on this label. If not, change label to match pattern before operating machine.**
- ▲ **Failure to do so could result in serious injury or death.**
- ※ See page 2-27 for details.

2 PATTERN CHANGE VALVE

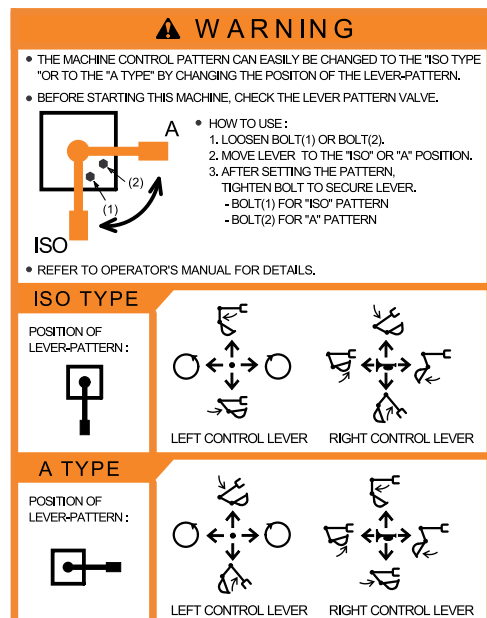

91N6-07410
91N6-07410

33) SWING BEARING GREASE (item 47)

This label is positioned on the front side of swing bearing housing.

※ See page 4-43 for details.

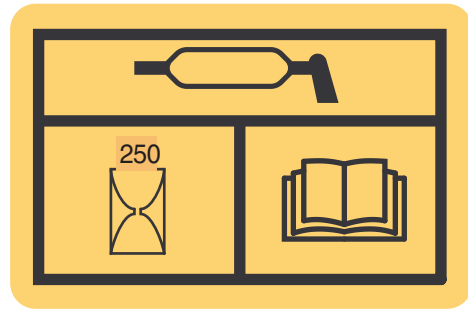

38090FW02

34) BATTERY POSITION (item 48)

This label is positioned on the side cover of the LH cowl.

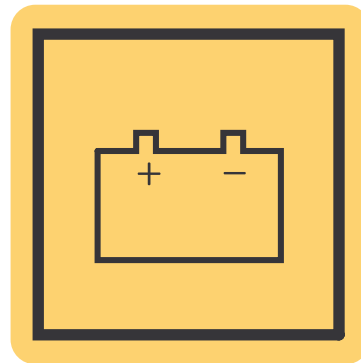

38090FW03

35) LUBRICATION OIL (item 49, old)

This label is positioned on the right side of the hydraulic tank.

※ Recommended lubrication oil is API CK-4.

※ See page 4-9 for details.

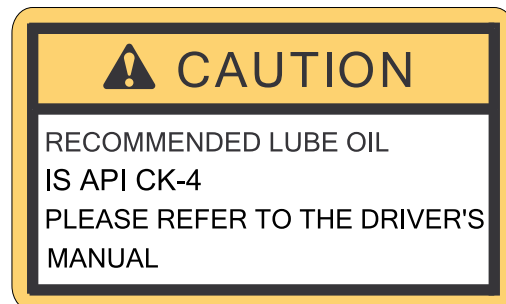

300A0SL03

36) FUEL SHUT OFF (item 50)

This label is positioned on the top side of the hydraulic tank.

※ Fill only with hydraulic oil.

※ Do not fill with diesel fuel.

▲ Relieve tank pressure with the engine off by removing the cap slowly to prevent burns from hot oil.

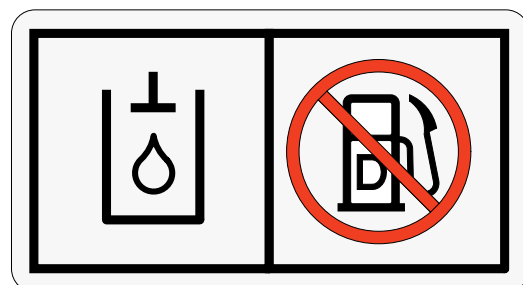

140WH90FW51

37) MCU/ECM CONNECTOR (item 51)

This label is positioned on the lower cover of the air conditioner inside the cab.

- ※ **MCU communicates the machine data through Laptop computer through RS232 service socket.**
- ※ **ECM communicates the engine data with cummins INSITE tool adapter through J1939 service socket.**
- ※ **See page 3-79 for details.**



235Z90FW52

38) ULTRA LOW SULFUR DIESEL (item 52)

This label is positioned on the right side of fuel filler neck.

- ※ **Use ultra low sulfur fuel only.**
- ※ **Ultra low sulfur fuel sulfur content \leq 15 ppm**

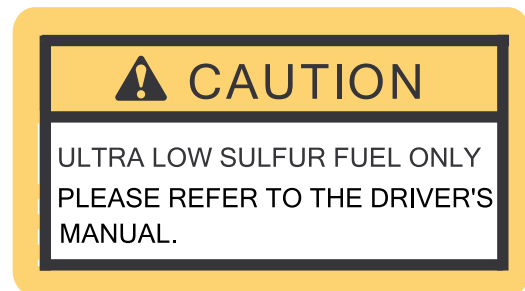

2609A0SL03

39) CUMMINS (item 53)

This label is located on the left rear stay of the cabin outside.

This machine is powered by Cummins



93WD-01500

40) SURGE TANK (item 54)

This label is positioned on the top of the surge tank.

This system must be filled slowly to prevent air locks.

- ※ **Fill rate \leq 11 lpm**

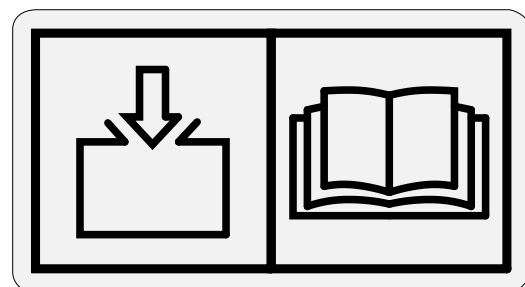

3009A0FW54

41) KEY OFF CAUTION (item 55)

This label is positioned on the right side window of the cab.

- ※ **Park on a flat place and stop the engine for inspecting and repairing. Properly TAG machine is not operational. (remove start key)**
- Extreme care shall be taken during maintenance work.**

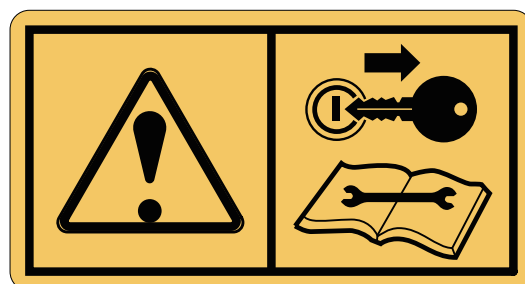

290F0FW05

42) RCV LEVER (item 56)

This label is positioned on the right window of inside the cab.

- ※ **When moving seat forward, interference is possible between cluster and RCV lever. To prevent such interference, follow the procedure below.**

- (1) Rotate cluster.
- (2) Adjust the seat position using the seat height adjustment lever (grey lever which is front center of seat).
- (3) Lower the console height using knob between RH console and seat cushion.
- (4) Push back console and seat at the same time by using console adjust knob which is located between the LH console and lower seat cushion.



290F0FW04

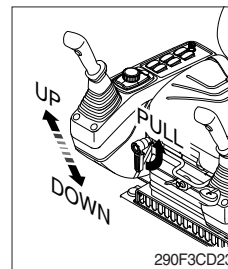

290F3CD23

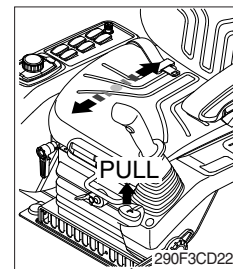

290F3CD22

43) DIESEL EXHAUST FLUID (item 57)

This label is positioned on the front of DEF/AdBlue® tank.

- ※ **Fill only with DEF/AdBlue® (Diesel Exhaust Fluid, standardised as IS 2241). Aqueous urea solution made with 32.5% high-purity urea and 67.5% deionized water.**
- ※ **Do not fill with diesel fuel.**

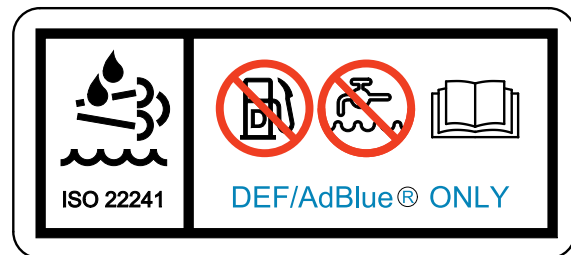

290F0SL04

44) DEF/AdBlue® TANK (item 58)

This label is positioned on the front of DEF/AdBlue® tank.

- ▲ **Be careful not to entering dust, sand or other contamination substances when you refill the DEF/AdBlue® into the tank. Otherwise, fatal problem such as engine idle locking, derating or engine stopping can be happen.**
- ※ **Do not pour DEF/AdBlue® overfull. Otherwise DEF/AdBlue® tank may freeze and burst in winter season.**
- ※ **Fill the tank with DEF/AdBlue® after key on and then turn off the start key.**

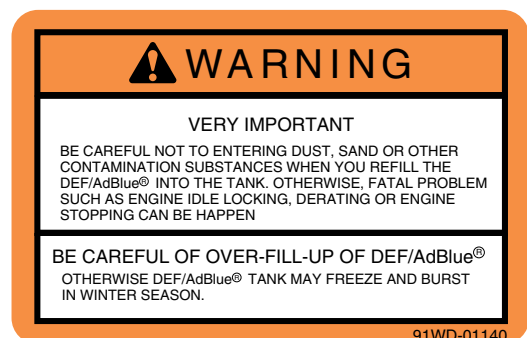

91WD-01140

91WD-01140

45) REFRIGERANT (item 59)

This label is positioned on the mount wa plate of the upper frame near the aircon compressor.

▲ Inhalation of A/C refrigerant gas in any form can result in serious injury or death.

※ Refer to page 4-56.

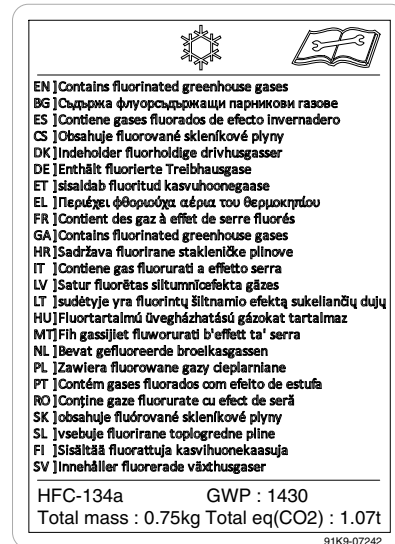

91K9-07252

46) HIGH PRESSURE (item 60)

This label is positioned on the top side of the hydraulic tank and engine hood.

▲ Do not touch hot or high pressure parts as it may cause severe burn.



94K8-01110

47) RCV CONTROL (item 61)

This label is positioned on the right window of inside the cab.

- ※ Read and understand the operation of the RCV lever.

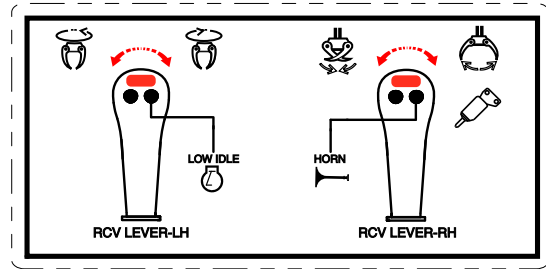

330FOSL05

48) BIO OIL (item 63)

This label is positioned on the RH cowl.

- ※ This machine works with PANOLIN HLP SYNTH 46.
- ※ Readily biodegradable according to OECD 301 B.
- ⚠ Do not mix with other bio-oil.

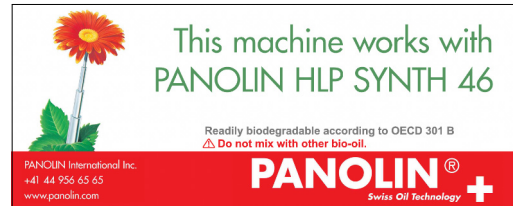

91WD-99110

49) FIRE EXTINGUISHER (item 64)

This label is located on the left rear stay, inside the cabin.

- ※ Read and understand the instructions label on the fire extinguisher.



91Q6-07290

50) EMC (item 65)

This label is positioned on the front side of the upper frame near the PIN plate.

- ※ This machine complies with the EMC directive ICES-002.
- ※ EMC : ElectroMagnetic Compatibility

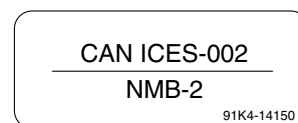

91K4-14150

51) LEFTOVER FUEL (item 66)

This label is positioned inside of the tool box.

- ⚠ Do not fuel a machine near open flames or sparks. Failure to comply may result in serious injury or death.
- ⚠ Properly clean areas of spillage.



91K4-02700

52) AIR COMPRESSOR (item 67)

This label is positioned inside of the tool box.

- ⚠ **Do not touch air compressor or it may cause severe burn.**



91Q4-13301

53) AIR COMPRESSOR-CAB (item 68)

This label is positioned on the right window of inside the cab.

- (1) Park on a flat place to use the air compressor.
- (2) Be sure the engine working during the use of air compressor. After the use, make sure the compressor switch off.
- (3) During the operation, do not use the other electrical devices (air conditioner, lights, stereo etc.).
- (4) Lower the air breather.
- (5) After the use, completely drain the water and the air inside the air tank.
- (6) Do not change the setting of the operating switch or the harness.
- (7) Do not touch the cylinder head during the operation.



91Q4-13320

54) PROPOSITION (item 70)

This label is positioned on the right window of the cab.

- ⚠ **Breathing diesel engine exhaust exposes you to chemicals known to the State of California to cause cancer and birth defects or other reproductive harm.**

- (1) Always start and operate the engine in a well-ventilated area.
- (2) If in an enclosed area, vent the exhaust to the outside.
- (3) Do not modify or tamper with the exhaust system.
- (4) Do not idle the engine except as necessary.

- ※ **For more information go to www.P65warnings.ca.gov/diesel.**

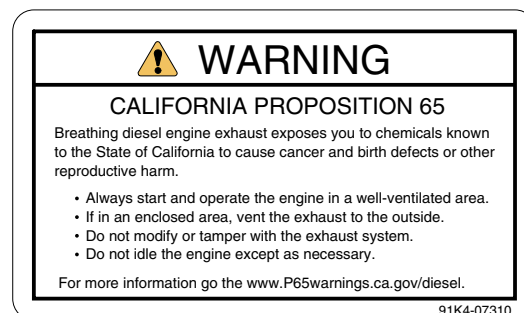

91K4-07310

Visibility

Before you start the machine, perform a walk-around inspection in order to ensure that there are no hazards around the machine.

While the machine is in operation, constantly survey the area around the machine in order to identify potential hazards as hazards become visible around the machine.

Your machine may be equipped with visual aids. Some examples of visual aids are Closed Circuit Television(CCTV), AAVM(Advanced Around View Monitoring) and mirrors. Before operating the machine, ensure that the visual aids are in proper working condition and that the visual aids are clean.

If may not be possible to provide direct visibility on large machines to all areas around the machine, appropriate job site organization is required in order to minimize hazards that are caused by restricted visibility. Job site organization is a collection of policies and procedures that coordinates machines and people that work together in the same area.

Examples of job site organization include the following:

- Safety instructions
- Controlled patterns of machine movement and vehicle movement
- Workers that direct traffic to move when it is safe
- Restricted areas
- Operator training
- Warning symbols or warning signs on machines or on vehicles
- A system of communication
- Communication between workers and operators prior to approaching the machine

Modifications of the machine configuration by the user could result in a restriction of the machine visibility. In this case, a new risk assessment must be performed according to ISO 5006:2017.

Restricted Visibility

The size and the configuration of this machine may result in areas that cannot be seen when the operator is seated. The following illustration of visual map provides an approximate visual indication of areas of significant restricted visibility. This illustration indicates restricted visibility areas at ground level inside a radius of 12.00m (40 ft) from the operator on a machine only with the use of right side mirror and left side mirror installed. (without the use of optional visual aids.) This illustration provide areas of restricted visibility for distances outside a radius of 12.00m (40 ft).

This machine may be equipped with optional visual aids (CCTV or AAVM) that may provide visibility to some of the restricted visibility areas. For areas that are not covered by the optional visual aids, the job site organization must be utilized to minimize hazards associated with this restricted visibility.

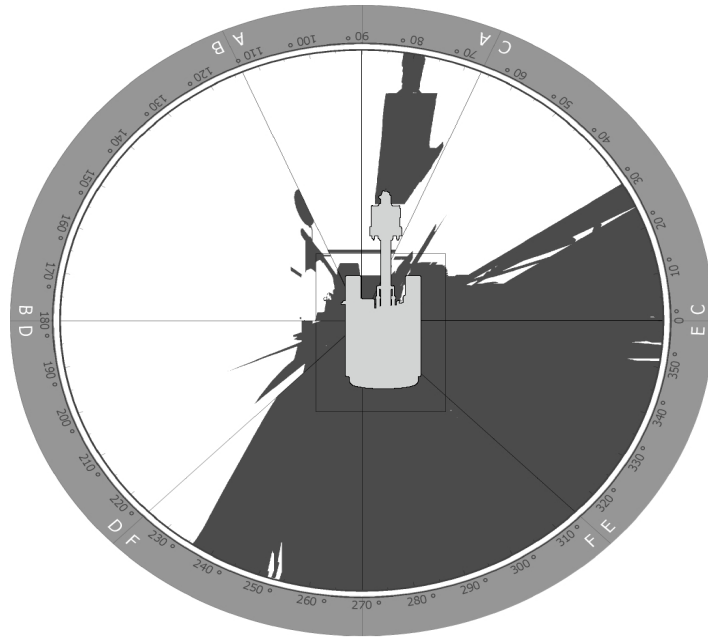

< Top view of the machine at ground level visibility without use of optional visual aids >

※ The shaded areas indicate the approximate location of areas with significant restricted visibility. (Radius = 12 m / 34 ft)

There is restricted visibility to the area directly behind the machine with no optional visual aids. Failure to make sure the area is clear could result in serious injury or death. Make sure that the area is clear before you start the reverse movement.

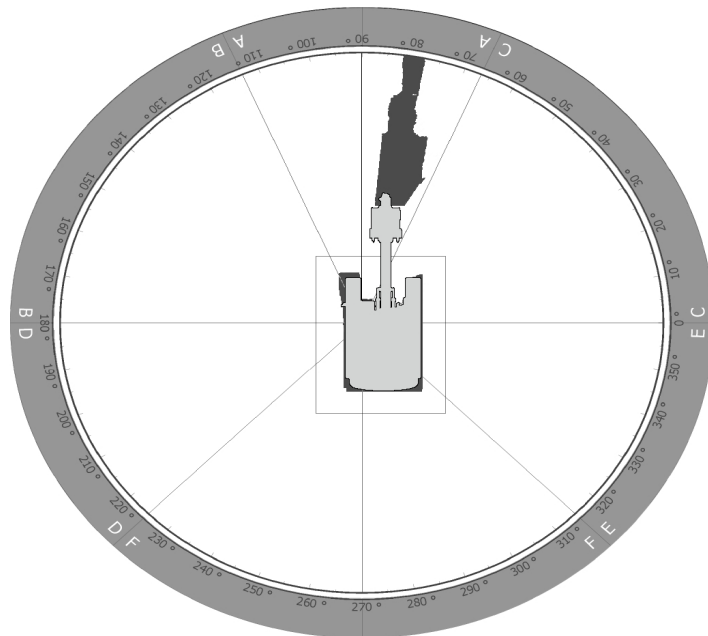

< Top view of the machine at ground level visibility with use of optional visual aids >

※ The shaded areas indicate the approximate location of areas with significant restricted visibility. (Radius = 12 m / 34 ft)

1. INSTRUCTION FOR NEW MACHINE

- 1) It takes about 100 operation hours to enhance its designed performance.
- 2) Operate according to the 3 steps below and avoid excessive operation for the initial hours.

Service meter	Load
Until 10 hours	About 60 %
Until 100 hours	About 80 %
After 100 hours	100 %

※ **Excessive operation may deteriorate the performance of the machine and shorten the life of the machine.**

3) Be careful during the initial 100 hours operation

- (1) Check daily for the level and leakage of fluids.
- (2) Check greasing points on a regular basis and grease all points as needed. Refer to greasing chart located on the machine.
- (3) Check over all hose connections, bolts, nuts and screws, on a daily basis.
- (4) Warm up the machine fully before operating.
- (5) Check all gauges occasionally during the operation.
- (6) Check if the machine is operating normally during operation of the machine.

4) After the initial 250 hours of operation replace the following:

Checking items	Hours
Engine oil	250
Engine oil filter	
Fuel filter element	
Fuel pre-filter element	
Hydraulic oil return filter	
Drain filter	
Pilot line filter element	
Swing reduction gear oil	
Travel reduction gear oil	

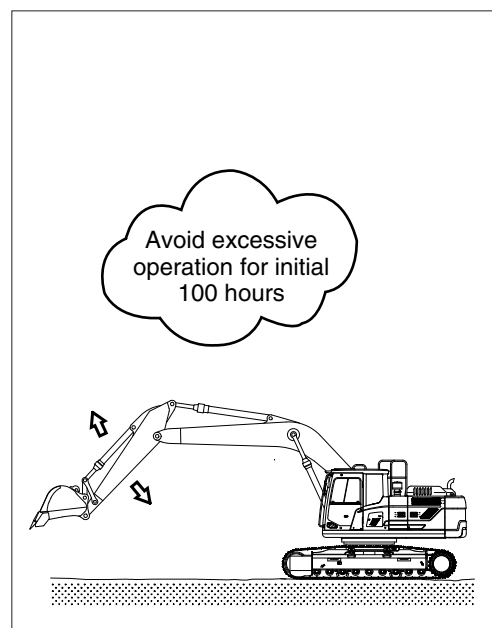

220A4OP01

2. CHECK BEFORE STARTING THE ENGINE

- 1) Look around and under the machine to check:
 - Check for loose nuts, bolts or wiring
 - Collection of dirt
 - Collection of dust at places which reach high temperature
 - Leakage of oil, fuel or coolant
 - Condition of the work equipment and hydraulic system.
- ※ Refer to section, Maintenance check list in chapter 4.
- 2) Adjust operator seat to best fit the operator.
- 3) Adjust all mirrors to best fit the operator.

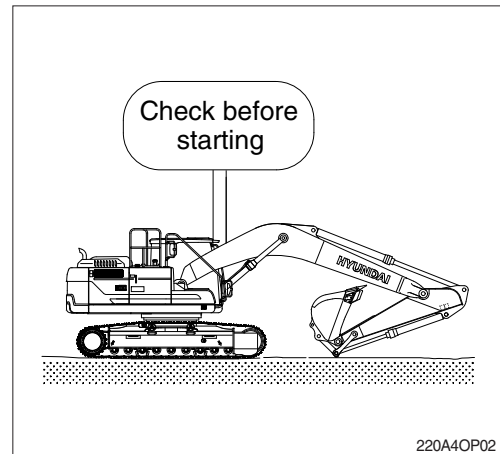

3. STARTING AND STOPPING THE ENGINE

1) CHECK INDICATOR LIGHTS

- (1) Confirm all operating levers are in the neutral position.
- (2) Turn the starting switch to the ON position.
Buzzer will sound for 4 seconds with HYUNDAI logo on cluster.
 - ※ If the ESL mode is set to enable mode, enter the password to start engine.
 - ※ If the incorrect password is entered a total of 5 times, you must wait 30 minutes before trying again.
 - ※ Refer to page 3-29 for ESL mode.
- (3) After initialization of cluster, the operating screen is displayed on LCD (1).
Also, self-diagnostic function is carried out.

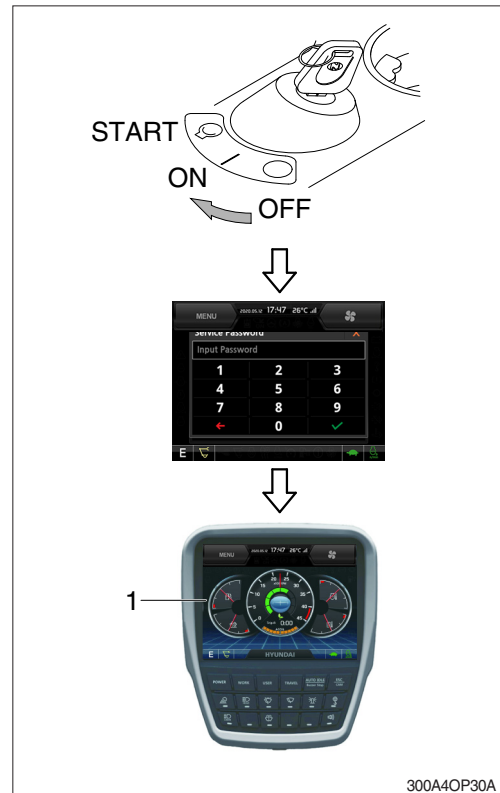

2) STARTING ENGINE IN NORMAL

▲ Check if any obstacles or people are in the working area. Sound the horn to warn anyone in the vicinity that you are starting the engine.

- (1) Turn the multimodal dial to low idle position.
- (2) Turn the starting switch to START position to start the engine.
 - △ Do not hold the starting switch in the START position for longer than 20 seconds. The start system may be seriously damaged.
 - ※ If the engine does not start, allow the stator to cool for about 2 minutes before re-attempting to start the engine again.
- (3) Release the starting switch instantly after the engine starts to avoid possible damage to the starting motor.



3) STARTING ENGINE IN COLD WEATHER

※ By following below steps, you will be able to improve startability and fuel consumption in cold weather.

▲ Always check for obstacles in the area and sound horn before starting the engine.

※ Check engine oil and fuel and replace as necessary. See page 7-29.

※ Top off coolant as needed.

※ When you turn ON starting switch, the fuel warmer automatically heats the fuel as needed by sensing coolant temperature.

- (1) Confirm all levers are in the neutral position.
- (2) Turn the multimodal dial to low idle position.
- (3) Turn the starting switch to the ON position, and wait 1~2 minutes. More time might be required, it depends on the ambient temperature.
- (4) Wait for five minutes to warm up the engine after the preheating pilot lamp turns off, and then turn the starting switch to the START position to start the engine.

※ If the engine does not start, allow the starter to cool for about 2 minutes before attempting to start the engine again.
- (5) Release the starting switch immediately after starting engine.
- (6) If the temperature of the coolant is lower than 30 °C (86 °F) the warming up process automatically starts.

※ Do not operate the working devices, or change the operation mode during the warming up.

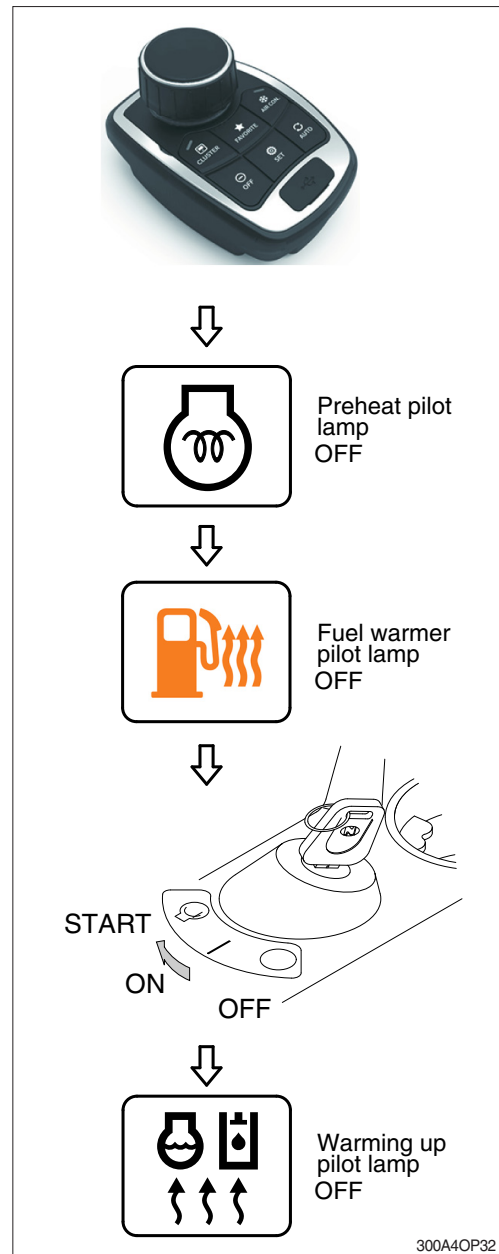

4) INSPECTION AFTER ENGINE START

Inspect and confirm the following after engine starts.

- (1) Is the oil level gauge of hydraulic tank in the normal operation range?
 - (2) Is there any leakage of oil or water?
 - (3) Are any warning lamps ON? (1-13)
The seat belt reminder warning lamp (16) pops up and the buzzer sounds until seat belt is fastened.
 - (4) Are indicators for coolant temperature gauge (14) and hydraulic temperature gauge (15) in the normal operating range?
 - (5) Is the engine sound and the color of exhaust gas normal?
 - (6) Are the sound and vibration normal?
- △ Do not increase engine speed quickly after starting, it can damage engine or turbocharger.
- ※ If there are problems in the cluster, stop the engine immediately and correct problems as required.



5) WARMING-UP OPERATION

- ※ The most suitable temperature for the hydraulic oil is about 50°C (122°F).
- △ If the hydraulic oil temperature drops below 25°C (77°F), sudden operation can damage the hydraulic system. So temperature must be raised to at least 25°C (77°F) before starting work.
- (1) Run the engine at low idle speed for 5 minutes.
 - (2) Speed up the engine by multimodal dial and run the engine at mid-range speed.
 - (3) Operate bucket lever for 5 minutes.
※ Do not operate anything except bucket lever.
 - (4) Run the engine at high speed and operate the bucket lever and arm lever for 5-10 minutes.
※ Operate only the bucket lever and arm lever.
 - (5) Finally this warming-up process will be completed by operating all cylinders several times along with the operation of swing and traveling.
- ※ Increase the time for warming-up during winter.

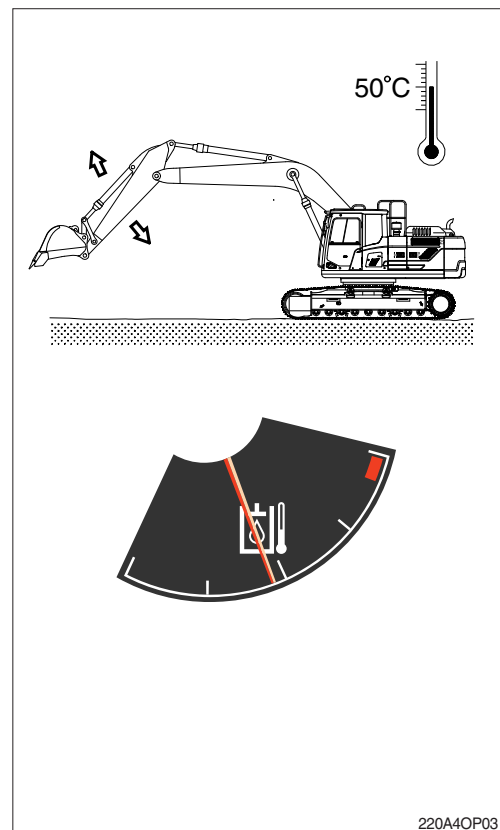

6) TO STOP THE ENGINE

- ※ If the engine is abruptly stopped before it has cooled down, engine life may be greatly shortened. Consequently, do not abruptly stop the engine apart from an emergency.
 - ※ In particular, if the engine has overheated, do not abruptly stop it but run it at low speed to allow it to cool gradually, then stop the engine.
- (1) Lower the bucket to the ground then put all the levers in the neutral position.
 - (2) Run the engine at low idle for about 5 minutes.
 - (3) Return the key of starting switch to the OFF position.
 - (4) Remove the key to prevent other people using the machine and the safety knob.
 - (5) Lock the cab door.

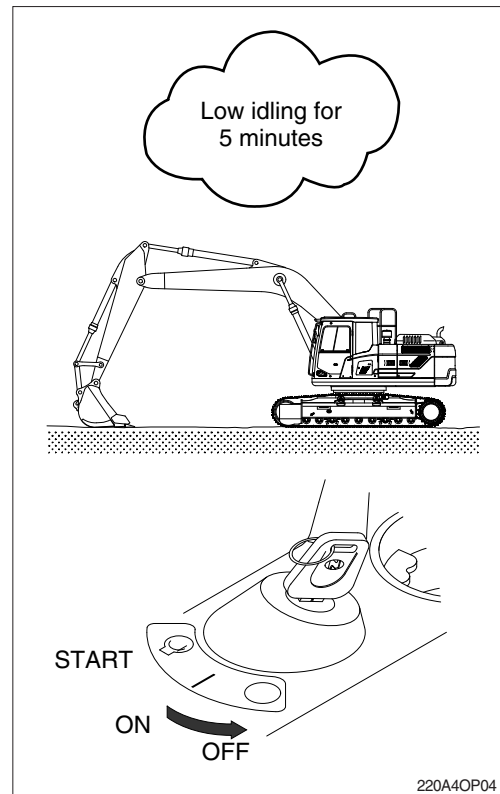

4. MODE SELECTION SYSTEM

1) STRUCTURE OF MECHATRONICS SYSTEM

CAPO, Computer Aided Power Optimization system, is the name of mode selection system developed by Hyundai.

※ Please refer to chapter 3, cluster for below modes setting.

(1) Power mode

Power mode designed for various work loads supports high performance and reduces fuel consumption.

- P mode : Heavy duty power
- S mode : Standard power
- E mode : Economy power

(2) Work mode

One of the two work modes can be selected for the optimal work condition of the machine operation.

① General work mode (bucket)

When key switch is turned ON, this mode is selected automatically.

② Work tool mode (breaker, crusher)

It controls the pump flow and system pressure for the optimal operation of breaker or crusher.

(3) User mode

① User mode is useful for setting the user preferable power quickly.

(engine speed, power shift and idle speed)

② There are two methods for use of user mode.

a. In operation screen

User mode switch is used to memorize the current machine operating status and activate the memorized user mode.

Refer to page 3-17.

b. In menu

Engine high idle rpm, auto idle rpm and pump torque (power shift) can be modulated and memorized separately in menu status.

- Each memory mode has a initial setting which is mid-range of max engine speed, power shift and auto idle speed.



- 1 Power mode switch
- 2 Work mode switch
- 3 User mode switch
- 4 Travel mode switch
- 5 Auto idle mode switch
- 6 LCD

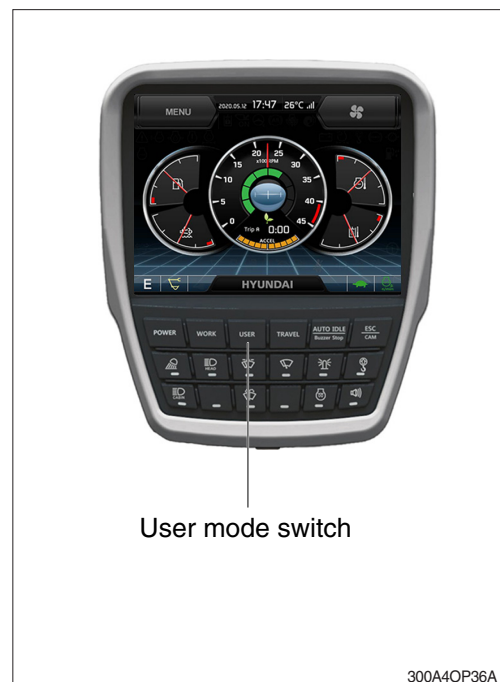

- High idle rpm, auto idle rpm and EPPR pressure can be adjusted and memorized in the U-mode.

※ Refer to the page 3-21 for setting the user mode (available on U mode only).

· LCD segment vs parameter setting

Step ()	Engine speed (rpm)	Idle speed (rpm)
1	1300	750
2	1400	800
3	1500	850
4	1600	900
5	1700	950
6	1800	1000 (auto decel)
7	1850	1050
8	1900	1100
9	1950	1150
10	2000	1200

※ One touch decel & low idle : 850 rpm



300A4OP37A

(4) Travel mode

 : Low speed traveling.

 : High speed traveling.

(5) Auto idle mode

Pilot lamp ON : Auto idle function is activated.

Pilot lamp OFF : Auto idle function is canceled.

(6) Monitoring system

Information of machine performance as monitored by the MCU can be displayed on the LCD. Refer to the page 3-25.

(7) Self diagnostic system

① MCU (Machine Control Unit)

The MCU diagnoses machine status and problems and displays fault code in the cluster (fault code detected by MCU is composed of HCESPN and FMI).

② Engine ECM (Electronic Control Module)

If the engine or relevant system has problem, engine ECM detects and displays on the LCD as fault codes (this code is composed of SPN and FMI).

※ Refer to the page 3-25 for LCD display.

(8) Anti-restart system

The system protects the starter from inadvertent restarting after the engine is already operational.

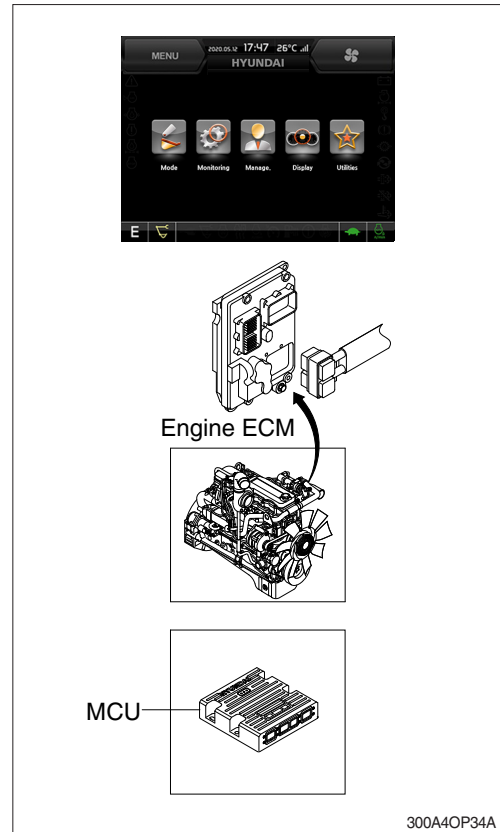

300A4OP34A

2) HOW TO OPERATE MODE SELECTION SYSTEM

(1) When start key switch is turned ON

- ① When start key switch is turned on, the cluster turns on and buzzer sounds for 4 seconds. Information including gauges and engine speed will be displayed on the LCD.
- ② Initial default mode settings are displayed in the cluster.

Mode		Status
Power mode	E	ON
Work mode		ON
Travel mode	Low ()	ON
Auto idle		ON

※ These setting can be changed at U mode.

- ③ Self-diagnostic function can be carried out from this point.

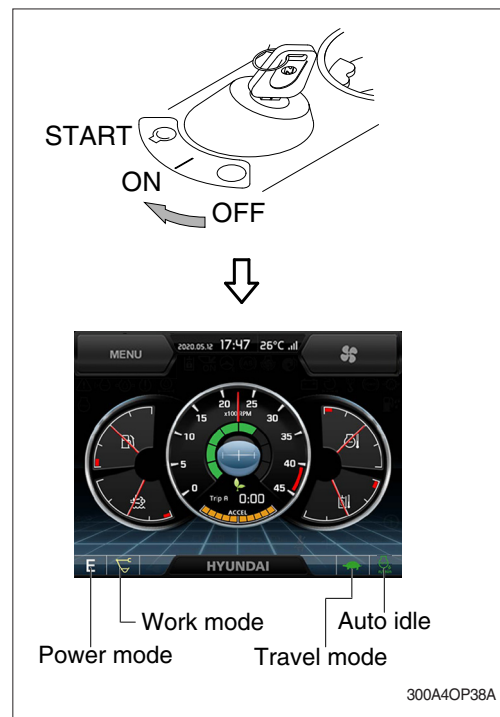

300A4OP38A

(2) After engine start

- ① When the engine is started, rpm display indicates low idle, 850 rpm.
- ② If coolant temperature is below 30°C, the warming up pilot lamp lights up. After 4 seconds the engine speed increases to 1100 rpm automatically to warm up the machine.
 - After 2-3 minutes, you can select any mode depending on job requirement.



3) SELECTION OF POWER MODE

(1) E mode

The multimodal dial is set to 10 and the auto idle mode is canceled.

Engine rpm	Effect
1600	Variable power control in proportion to lever stroke (improvement in fuel efficiency) ※ Same power as S mode in full lever operation.

- ※ When the multimodal dial is located below 9 the engine speed decreases about 50~100 rpm per dial set.

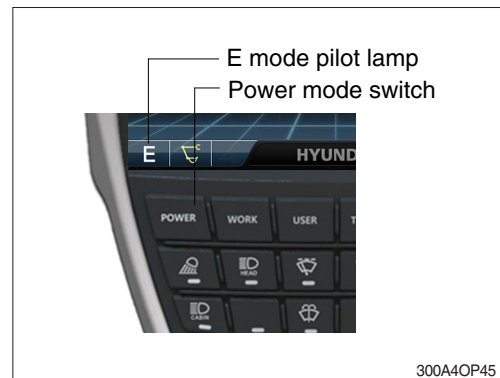

(2) S mode

The multimodal dial is set to 10 and the auto idle mode is canceled.

Engine rpm	Effect
1600	Standard power

- ※ When the multimodal dial is located below 9 the engine speed decreases about 50~100 rpm per dial set.

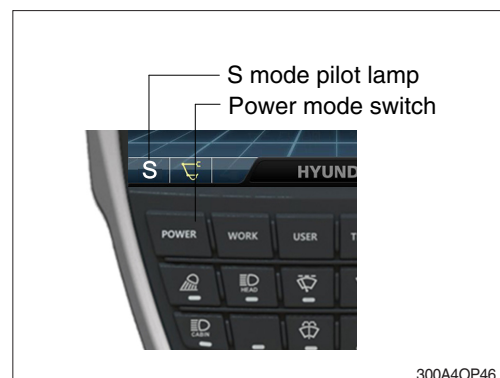

(3) P mode

The multimodal dial is set to 10 and the auto idle mode is canceled.

Engine rpm	Effect
1700	Approximately 120 % of power and speed available than S mode.

※ When the multimodal dial is located below 9 the engine speed decreases about 50~100 rpm per dial set.

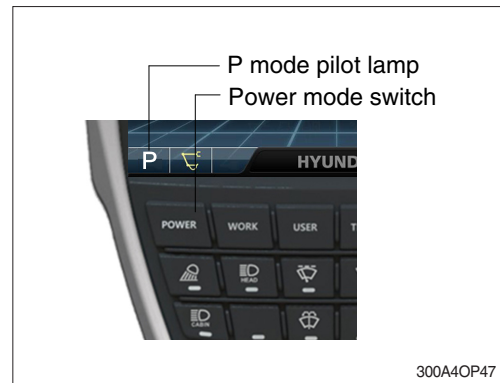

5. OPERATION OF THE WORKING DEVICE

※ **Confirm the operation of control lever and working device.**

- 1) Left control lever controls arm and swing.
- 2) Right control lever controls boom and bucket.
- 3) When you release the control lever, control lever returns to neutral position automatically.

※ **When operating swing, consider the swing distance by inertia.**

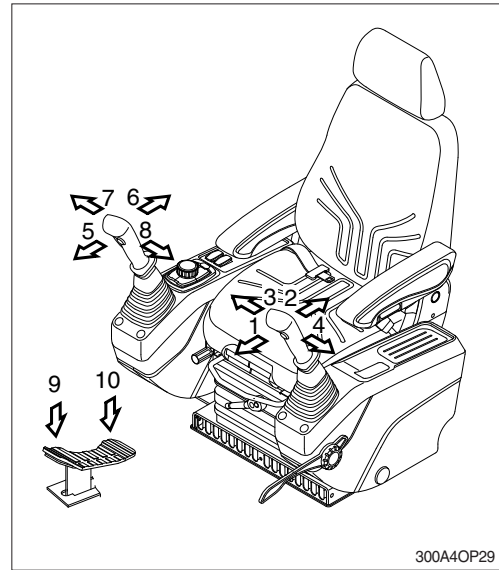

※ **Left control lever**

- 1 Arm roll-out
- 2 Arm roll-in
- 3 Swing right
- 4 Swing left

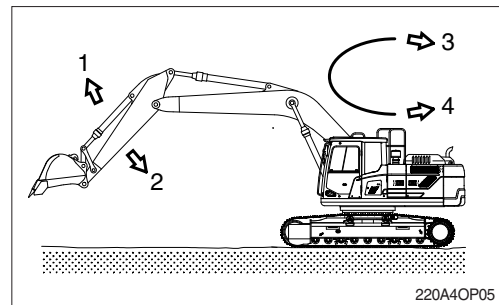

※ **Right control lever**

- 5 Boom (or 1st boom) lower
- 6 Boom (or 1st boom) raise
- 7 Bucket roll-out
- 8 Bucket roll-in

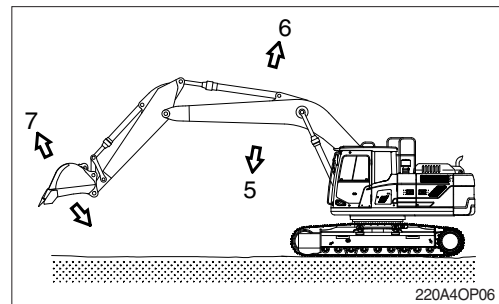

※ **Single pedal (option)**

- 9 2nd boom lower
- 10 2nd boom raise

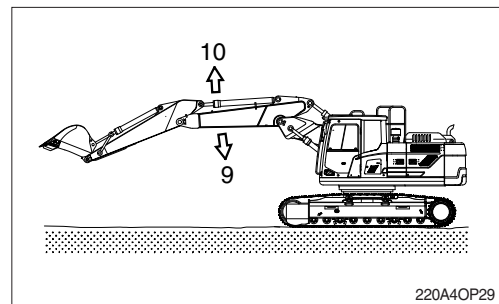

6. TRAVELING OF THE MACHINE

1) BASIC OPERATION

(1) Traveling position

The travel motor is in the rear and the working device is forward.

▲ **Be careful as the traveling direction will be the opposite when the machine is rotated 180°.**

(2) Traveling operation

It is possible to travel by either travel lever or pedal.

- ※ **Do not travel continuously for a long time.**
- ※ **Reduce the engine speed and travel at a low speed when traveling on uneven ground.**

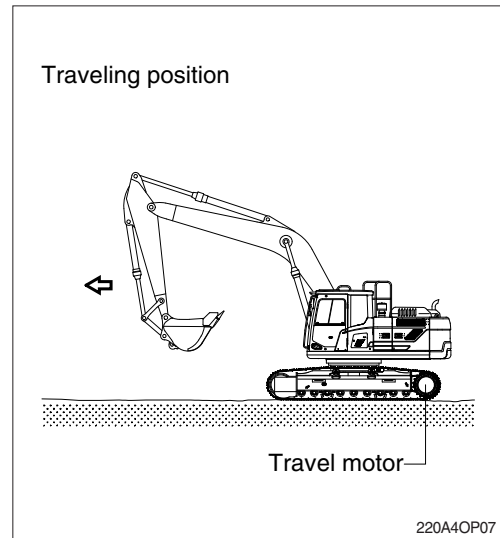

(3) Forward and backward traveling

When the left and right travel levers or pedals are pushed at the same time, the machine will travel forward or backward depending on your selection.

- ※ **The speed can be controlled by the operation stroke of lever or pedal and change of direction will be controlled by difference of the left and right stroke.**

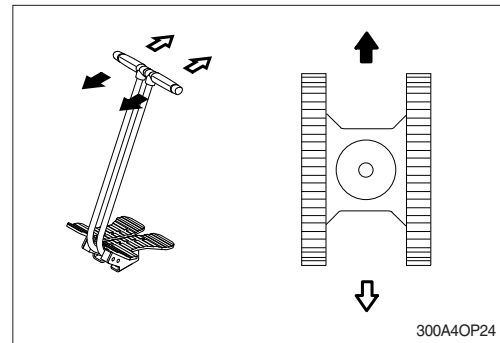

(4) Pivot turning

Operating only one side of lever or pedal makes the change of direction possible by moving only one track.

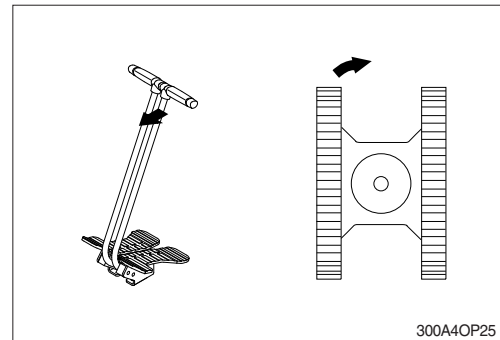

(5) Counter rotation

It is to rotate the undercarriage (only) while not advancing the machine forward or backward. This is accomplished by moving the travel levers and or pedals in the opposite direction of each other.

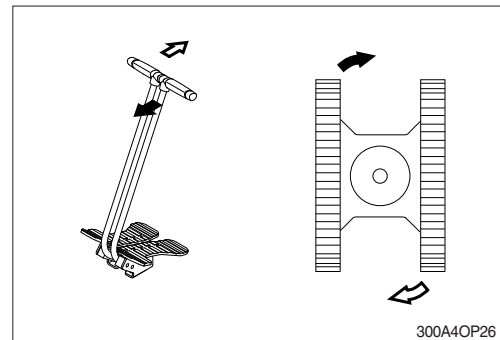

2) TRAVELING ON A SLOPE

- (1) Make sure that the travel lever is properly maneuvered by confirming the travel motor is in the right location.
 - (2) Maintain the bucket 20 to 30 cm (1 ft) from the ground so that it can be used as a brake in the event of an emergency.
 - (3) If the machine starts to slide or loses stability, lower the bucket immediately as it will help slow or stop the machine.
 - (4) When parking on a slope, use the bucket as a brake.
- ※ **Machine cannot travel effectively on a slope when the oil temperature is low. Do the warm-up operation when it is going to travel on a slope.**
- ▲ **Be careful when working on slopes. It may cause the machine to lose its balance and turn over. Serious injury or death could occur.**
- ▲ **Be sure to keep the travel speed switch on the LOW (turtle mark) while traveling on a slope.**
- ▲ **Be sure to keep the swing lock/fine switch on the LOCK while traveling on a slope (if equipped).**

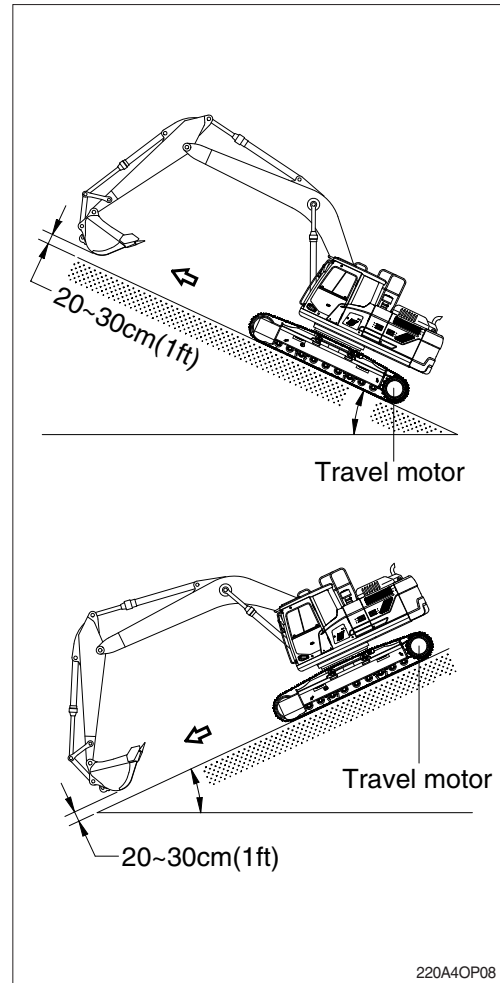

3) TRAVELING ON SOFT GROUND

- ※ **If possible, avoid operating on soft ground.**
- (1) Move forward as far as machine can move.
 - (2) Take care not to go beyond the depth where towing is impossible on soft ground.
 - (3) When driving becomes impossible, lower bucket and use boom and arm to pull the machine. Operate boom, arm, and travel lever at the same time to avoid the machine sinking.

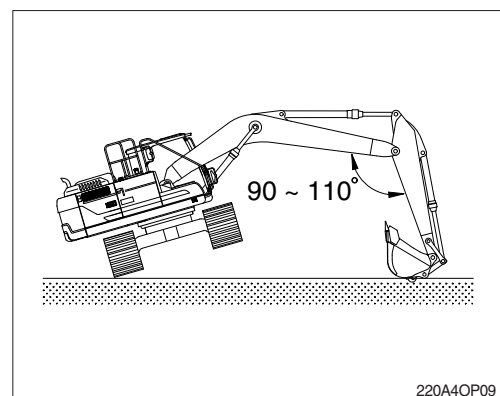

4) TOWING THE MACHINE

Tow the machine as follows when it can not move on its own.

- (1) Tow the machine after hooking the wire rope to the frame as shown in the upper right illustration.
- (2) Hook the wire rope to the frame and put a support under each part of wire rope to prevent damage.

※ **Never tow the machine using only the tie hole, because this may break.**

▲ **Make sure no personnel are standing close to the tow rope as serious injury or death could occur if it breaks.**

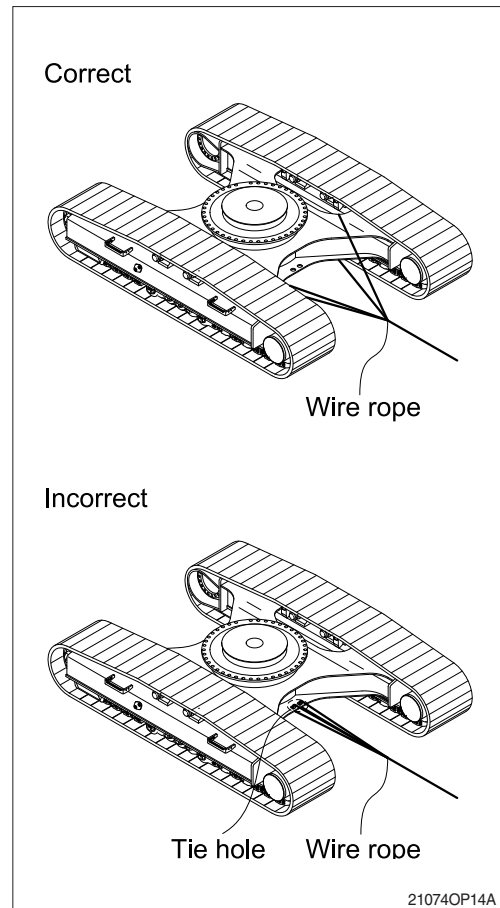

7. EFFICIENT WORKING METHOD

- 1) Do the digging work by arm.

Use the pulling force of arm for digging and use together with the digging force of the bucket if necessary.

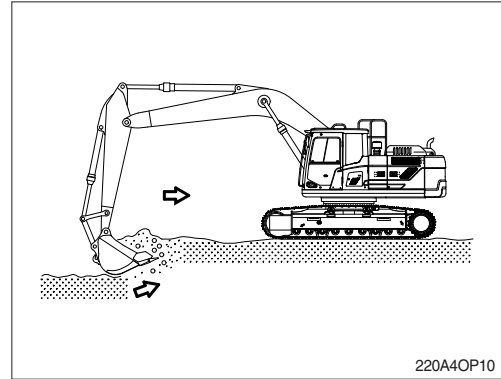

- 2) When lowering and raising the boom operate softly for the beginning and the end.

In particularly, sudden stops while lowering the boom may cause damage to the machine.

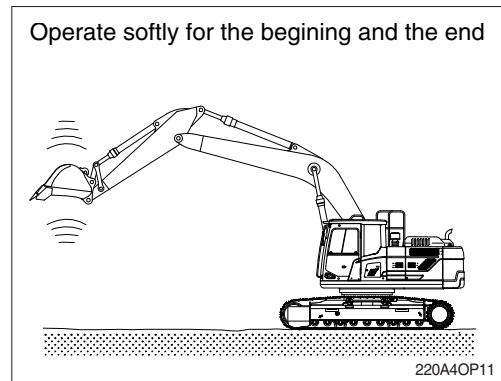

- 3) The digging resistance and wearing of tooth can be reduced by putting the end of bucket tooth to the digging direction.

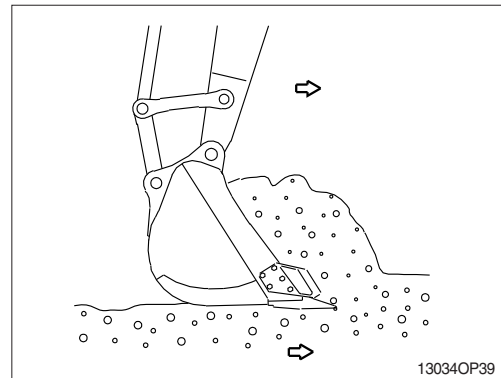

- 4) Set the tracks parallel to the line of the ditch to be excavated when digging ditch. Do not swing while digging.

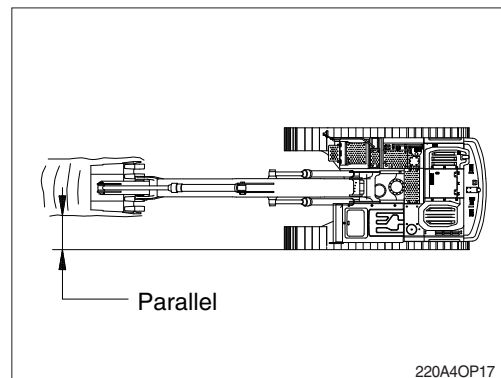

- 5) Dig slowly while keeping the angle of boom and arm at a 90-110° when maximum digging force is required.

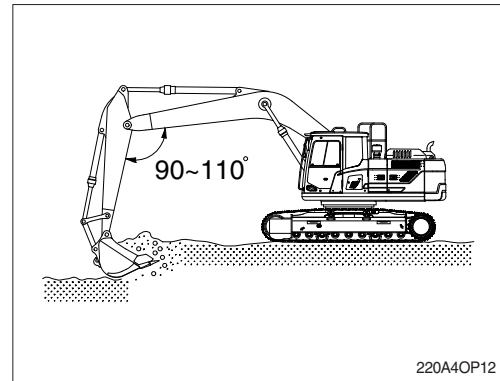

- 6) Leave a small margin of cylinder stroke to prevent damage of cylinder when working with the machine.

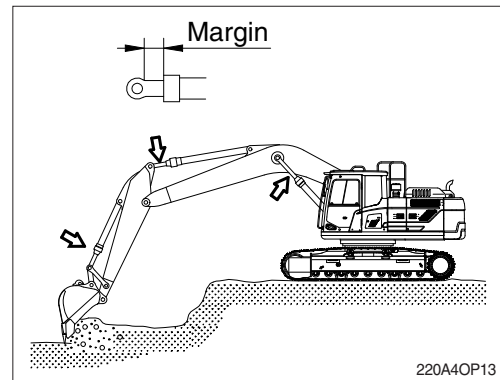

- 7) Keep the bucket to the dumping position and the arm horizontal when dumping the soil from the bucket.
Operate bucket lever 2 or 3 times when hard to dump.

※ Do not use the impact of bucket tooth when dumping.

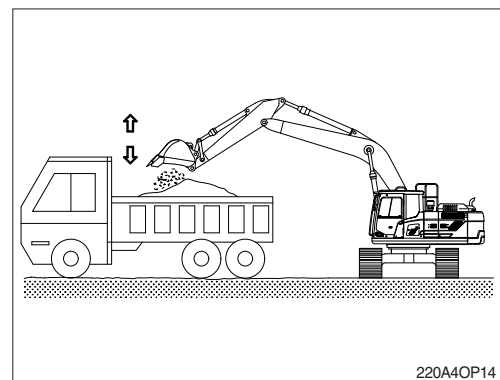

- 8) Operate stop of swing considering the swing slip distance is created by inertia after neutralizing the swing lever.

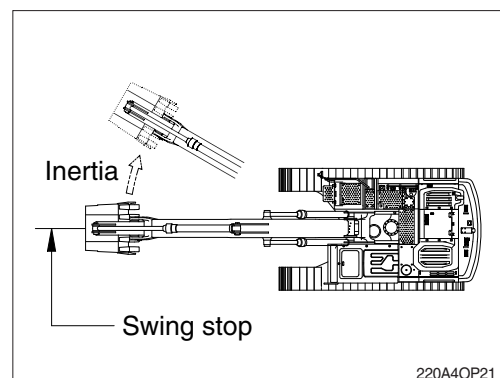

- 9) If the excavation is in an underground location or in a building, make sure that there is adequate overhead clearance and that there is adequate ventilation.

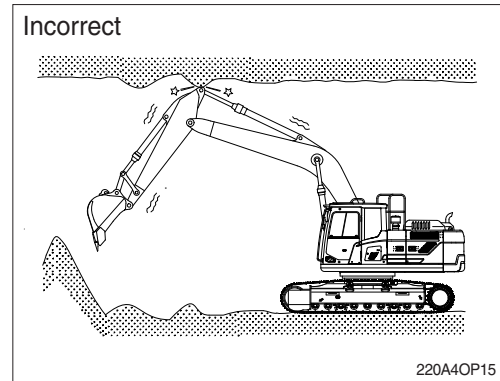

- 10) Do not use the dropping force of the work equipment for digging.
The machine can be damaged by the impact.

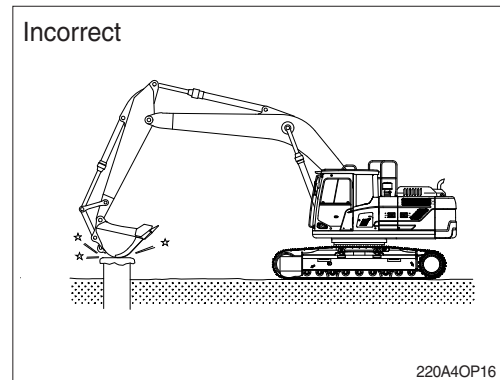

- 11) Do not use the bucket to crack hard objects like concrete or rocks.
This may break a tooth or pin, or bend boom.

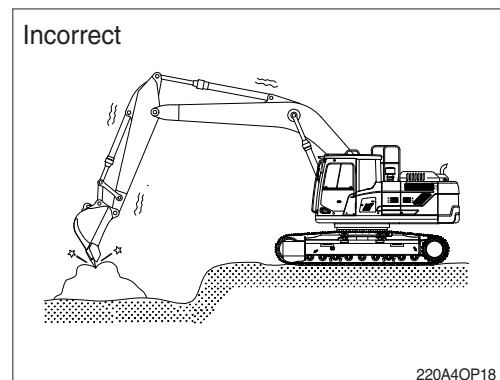

12) NEVER CARRY OUT EXCESSIVE OPERATIONS

Operation exceeding machine performance may result in accident or failure, causing serious injury or death.

Carry out lifting operation within specified load limit.

Never carry out operations which may damage the machine such as overload or over-impact-load.

Never travel while carrying a load.

If you need an overload warning device installed for object handling procedure, please contact your local Hyundai distributor.

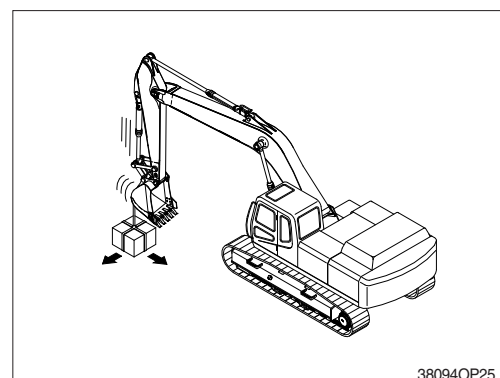

12) BUCKET WITH HOOK

When carrying out lifting work, the special lifting hook is necessary.

The following operations are prohibited.

- Lifting loads with a wire rope fitted around the bucket teeth.
- Lifting loads with the wire rope wrapped directly around the boom or arm.

When performing lifting operation, securely hook the wire rope onto the special lifting hook.

When performing lifting operation, never raise or lower a person.

Due to the possible danger of the load falling or of collision with the load, no persons shall be allowed in the working area.

Before performing lifting operation, designate an operation supervisor.

Always execute operation according to their instructions.

- Execute operating methods and procedures under their direction.
- Select a person responsible for signaling.
Operate only on signals given by such person.

Never leave the operator's seat while lifting a load.

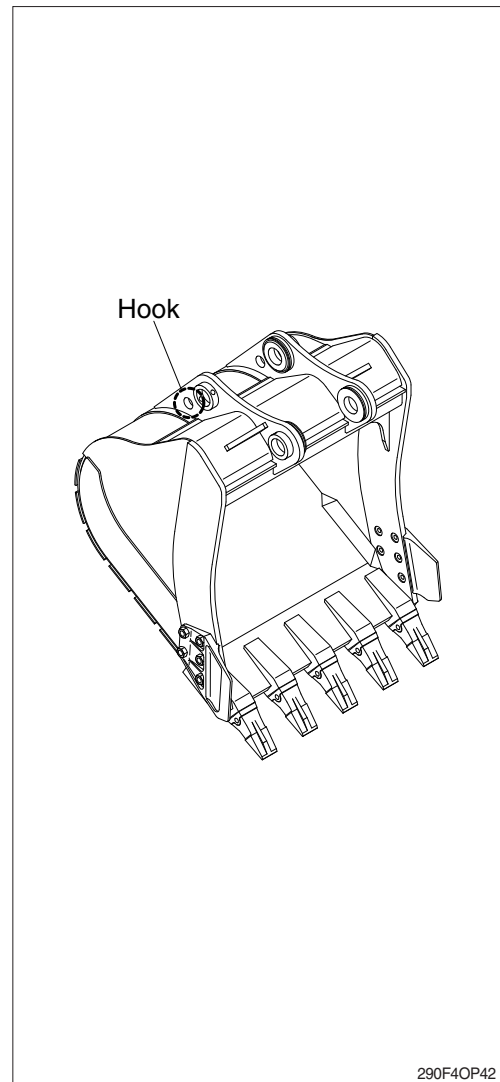

8. OPERATION IN THE SPECIAL WORK SITES

1) OPERATING THE MACHINE IN A COLD WEATHER

- (1) Use proper engine oil and fuel for the weather.
- (2) Fill the required amount of antifreeze in the coolant.
- (3) Refer to the starting engine in cold weather. Start the engine and extend the warming up operation.
- (4) Be sure to open the heater cock when using the heater.
- (5) Always keep the battery completely charged.
※ **Discharged batteries will freeze more easily than fully charged.**
- (6) Clean the machine and park on wood plates.

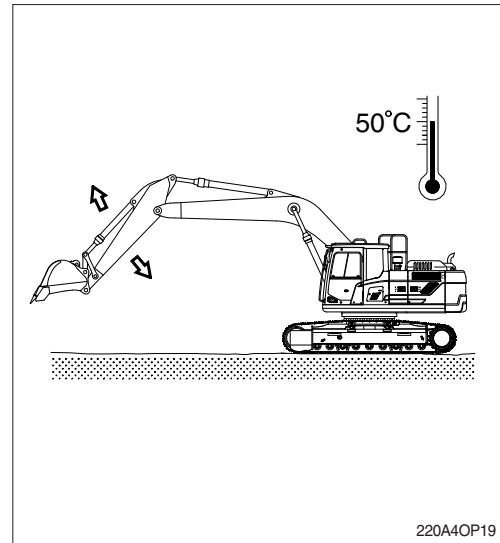

2) OPERATION IN SANDY OR DUSTY WORK SITES

- (1) Inspect air cleaner element frequently. Clean or replace element more frequently if warning lamp lights up and buzzer sounds simultaneously, regardless of inspection period.
※ **Replace the inner and outer element after 4 times of cleaning.**
- (2) Inspect radiator, oil cooler and condenser frequently, and keep cooling fins clean.
- (3) Prevent sand or dust from getting into fuel tank and hydraulic tank during refilling.
- (4) Prevent sand or dust from penetrating into hydraulic circuit by tightly closing breather cap of hydraulic oil tank. Replace hydraulic oil filter and air breather element frequently. Also, replace the fuel filter frequently.
- (5) Keep all lubricated parts, such as pins and bushings, clean at all times.
- (6) If the air conditioner and heater filters clog, the heating or cooling capacity will drop. Clean or replace the filter element more frequently.
- (7) Clean electrical components, especially the starting motor and alternator, to avoid accumulation of dust.

3) SEA SHORE OPERATION

- (1) Prevent ingress of salt by securely tightening plugs, cocks and bolts of each part.
- (2) Wash machine after operation to remove salt residue.
Pay special attention to electrical parts, hydraulic cylinders and track tension cylinder to prevent corrosion.
- (3) Inspection and lubrication must be carried out more frequently.
Supply sufficient grease to replace all old grease in bearings which have been submerged in water for a long time.

4) OPERATION IN MUD, WATER OR RAIN WORK SITES

- (1) Perform a walk around inspection to check for any loose fittings, obvious damage to the machine or any fluid leakage.
- (2) After completing operations, clean mud, rocks or debris from the machine. Inspect for damage, cracked welds or loosened parts.
- (3) Perform all daily lubrication and service.
- (4) If the operations were in salt water or other corrosive materials, make sure to flush the affected equipment with fresh water.

5) OPERATION IN ROCKY WORK SITES

- (1) Check for damage to the undercarriage and for looseness, flaws, wear and damage in bolts and nuts.
- (2) Loosen the track tension slightly when working in such areas.
- (3) Do not turn the undercarriage directly over the sharp edge rock.

9. NORMAL OPERATION OF EXCAVATOR

The following may occur during operation due to the nature of a hydraulic excavator.

- 1) When rolling in the arm, the roll-in movement stops momentary at point X in the picture shown, then recovers speed again after passing point X. This is because movement by the arm weight is faster than the speed of oil flow into the cylinder.
- 2) When lowering the boom, you may hear continuous sound. This is caused by oil flow in the valve.
- 3) Overloaded movement will produce sound caused by the relief valves, which are for the protection of the hydraulic systems.
- 4) When the machine is swinging or stopped, a noise near the swing motor may be heard. The noise is generated when the brake valve relieves.

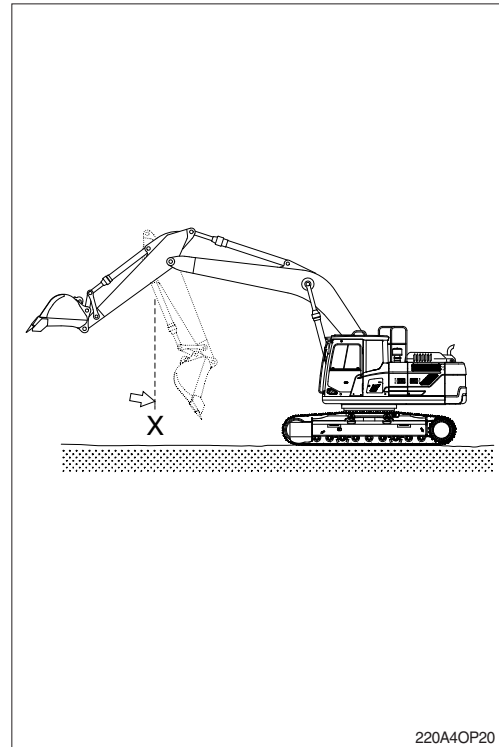

10. ATTACHMENT LOWERING (when engine is stopped)

1) On machines equipped with an accumulator, for a short time (within 1 minute) after the engine is stopped, the attachment will lower under its own weight when the attachment control lever is shifted to LOWER. This happens only when the starting switch is ON and the safety knob is in the UNLOCK position. After the engine is stopped, set the safety knob to the LOCK position.

⚠ Be sure no one is under or near the attachment before lowering the boom. Failure to comply could result in serious injury or death.

2) The accumulator is filled with high-pressure nitrogen gas, and it is extremely dangerous if it is handled in the wrong way. Always observe the following precautions.

⚠ Never make any hole in the accumulator, expose it to flames or fire.

⚠ Do not weld anything to the accumulator.

※ When carrying out disassembly or maintenance of the accumulator, or when disposing of the accumulator, it is necessary to release the gas from the accumulator.

A special air bleed valve is necessary for this operation, so please contact your Hyundai distributor.

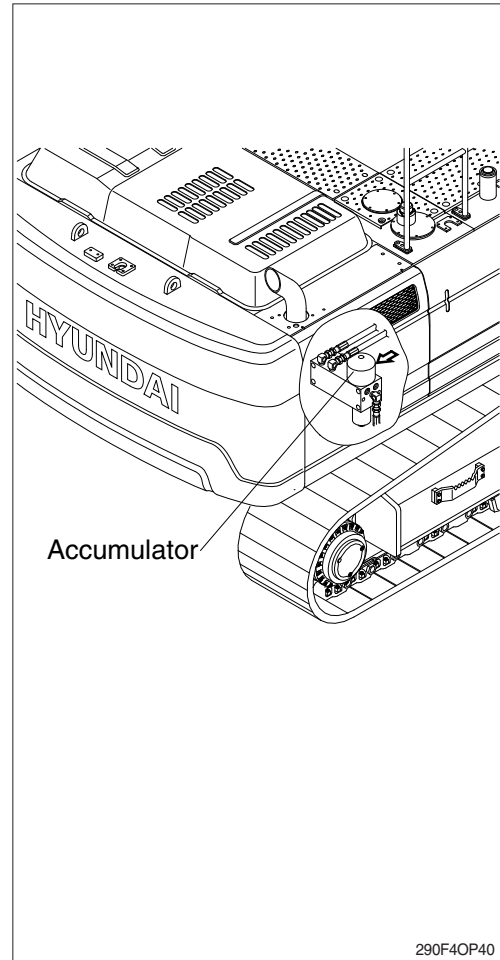

290F40P40

11. STORAGE

When storing the machine for longer than 1 month, follow these procedures:

1) BEFORE STORAGE

(1) Cleaning the machine

Clean the machine. Check and adjust tracks.
Grease each lubrication part.

(2) Lubrication position of each part

Change all oil.

- ※ Be particularly careful when you reuse the machine. As oil can be diluted during storage. Apply an anticorrosive lubricant on the exposed part of piston rod of cylinder and in places where the machine rusts easily.

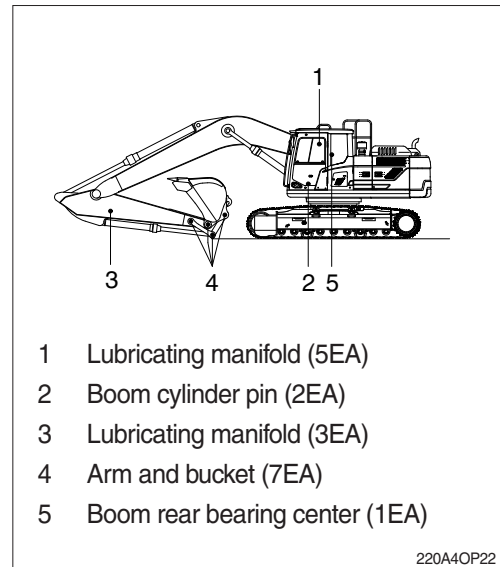

(3) Master switch

Turn OFF the master switch mounted electric box and store the machine.

- ▲ Turn OFF the master switch after the lamp goes OFF.
 - ▲ It may cause severe failure of aftertreatment device. Because aftertreatment system still is working while the lamp lights up.
- (4) Be sure to mix anticorrosive antifreezing solution in the radiator.

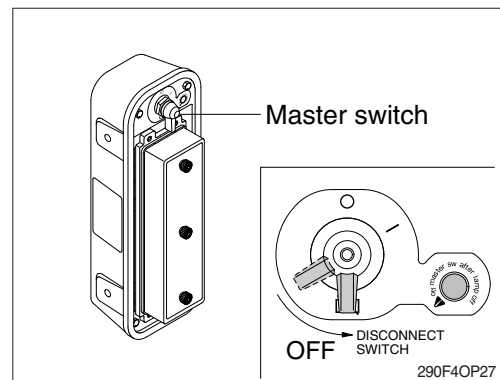

(5) Prevention of dust and moisture

Keep machine dry. Store the machine setting wood on the ground.

- ※ Cover exposed part of piston rod on cylinder.
- ※ Lower the bucket to the ground and set a support under track.

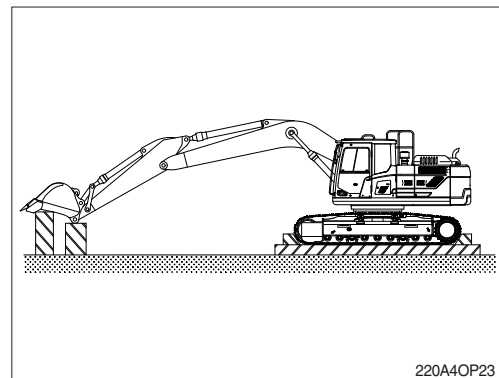

2) DURING STORAGE

Start engine and move the machine and work equipment once a month and apply lubrication to each part.

- ※ Check the level of engine oil and coolant and fill if required when starting engine.
- ※ Clean the anticorrosive on the piston rod of cylinder.
- ※ Operate the machine such as traveling, swing and work equipment operation to make sure enough lubrication of all functional components.

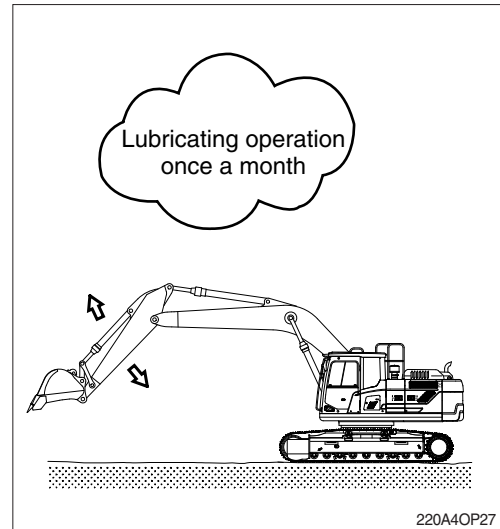

※ BATTERY

- ① Once a month, start the engine for 15 minutes (or use a charger) to charge the battery.
- ② Every 2 months, check the battery voltage and keep battery voltage over 25.08V.
- ③ If the machine stock period is over 6 months, disconnect the battery negative (-) terminal.

3) AFTER STORAGE

Carry out the following procedure when taking out of a long time storage.

- (1) Wipe off the anticorrosive lubricant on the hydraulic piston rod.
- (2) Completely fill fuel tank, lubricate and add oil.

(3) When storage period is over 6 months

If the machine stock period is over 6 months, carry out the following procedure.

This procedure is to drain condensation water for the **swing reduction gear** durability.

- ※ Remove the drain port plug and drain the water until the gear oil comes out and then tighten the drain plug.
- ※ Refer to chapter 4, Maintenance for the drain plug location.
- ※ If the machine is stored without carrying out the monthly lubricating operation, consult your Hyundai dealer for service.

12. RCV LEVER OPERATING PATTERN

1) PATTERN CHANGE VALVE NOT INSTALLED (standard)

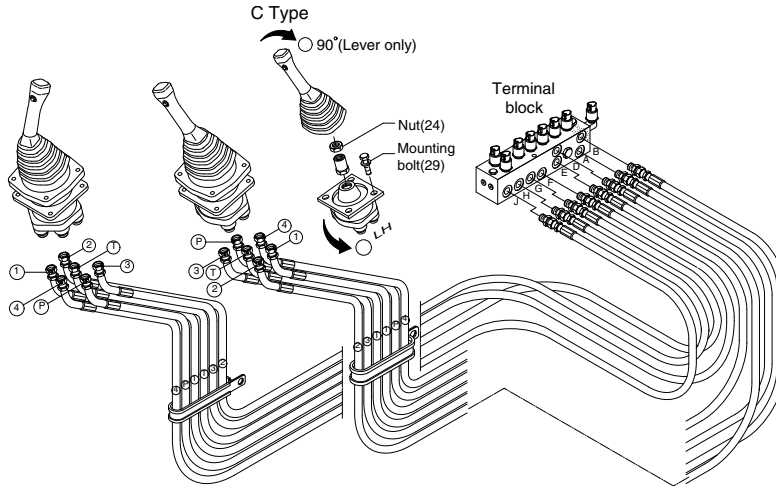

※ Whenever a change is made to the machine control pattern, also exchange the pattern label in the cab to match the new pattern.

※ The hose modification works must be carried out between RCV lever and terminal block (Not between terminal block and MCV).

220A4OP41

Pattern	Operation		Control function	Hose connection (port)					
	Left RCV lever	Right RCV lever		RCV lever	Change of Terminal block				
					From	To			
ISO Type			Left	1 Arm out	②	D	-		
				2 Arm in	④	E	-		
				3 Swing right	③	B	-		
				4 Swing left	①	A	-		
	Right	5 Boom lower	④	J	-				
		6 Boom raise	②	H	-				
		7 Bucket out	①	G	-				
		8 Bucket in	③	F	-				
Hyundai			Left	1 Boom lower	②	D	J		
				2 Boom raise	④	E	H		
				3 Swing right	③	B	-		
				4 Swing left	①	A	-		
	Right	5 Arm out	④	J	D				
		6 Arm in	②	H	E				
		7 Bucket out	①	G	-				
		8 Bucket in	③	F	-				
A Type			Left	1 Boom lower	②	D	J		
				2 Boom raise	④	E	H		
				3 Bucket in	③	B	F		
				4 Bucket out	①	A	G		
	Right	5 Arm out	④	J	D				
		6 Arm in	②	H	E				
		7 Swing right	①	G	B				
		8 Swing left	③	F	A				
B Type			Left	① Loosen the RCV lever mounting bolt (29) and rotate lever assy 90° counterclockwise; then install.					
				② To put lever in correct position, disassemble nut (24) and rotate only lever 90° clockwise.					
				Right			Same as ISO type		

2) PATTERN CHANGE VALVE INSTALL (option)

※ If the machine is equipped with the pattern change valve, the machine operation pattern can be easily changed.

※ Whenever a change is made to the machine control pattern also exchange the pattern label in the cab to match the new pattern.

Operation	ISO type	A type
Left RCV lever		
Right RCV lever		

(1) The machine control pattern can be changed from the "ISO type" to "A type" by changing the position of the lever.

▲ Before starting the machine, check the lever position of pattern change valve and actual operating of attachment.

(2) Change of operating pattern

- ① Loosen bolt.
- ② Move lever to the "ISO" or "A" position.
- ③ After the lever is set, tighten the bolt in order to secure the lever.
 - Position ① for "ISO" pattern.
 - Position ② for "A" pattern.

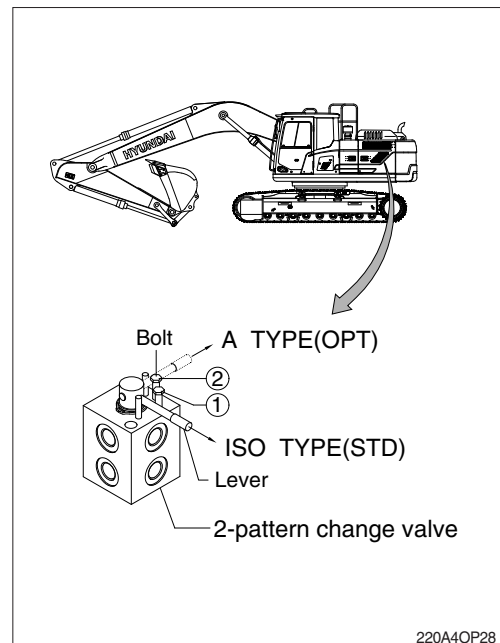

220A4OP28

13. EXHAUST SYSTEM CLEANING

- ※ Exhaust system cleaning events for the catalyst system will happen automatically under normal engine conditions and are controlled by the ECM as long as the exhaust system cleaning Inhibit switch is not engaged. During automatic exhaust system cleaning, any warning lamps or fault codes will not occur so the operator can not notice the cleaning is being performed.
- ※ If automatic exhaust system cleaning does not occur, the exhaust system cleaning lamp will illuminate, indicating to the operator that they will need to perform a manual exhaust system cleaning.
- ※ The HEST Lamp will be illuminated during the entire exhaust system cleaning.
- ※ While the exhaust system cleaning occurs, fuel consumption will be increased 20~30% more than usual due to post fuel injection to the exhaust system to reach enough exhaust temperature for regeneration.
- ※ The operator can check logs of exhaust system cleaning events on an engine diagnostic tool (INSITE).
- ▲ Tampering, modifying, or removing any component of the exhaust system is strictly prohibited by law.
- ▲ Exhaust system cleaning generates hot exhaust and causes hot exhaust system components.
- ▲ Exhaust system components get very hot and can cause severe burns. Risk of fire.
- ▲ Do not perform exhaust system cleaning in a flammable environment.

(1) Exhaust system cleaning warning lamp

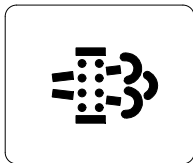

2609A3CD19

This warning lamp will light up or blink when the exhaust system cleaning is needed or activated.

- ※ Refer to page 3-9 for details.
- ※ The machine must be in a fireproof area during the entire exhaust system cleaning process.

(2) Exhaust system cleaning inhibit warning lamp

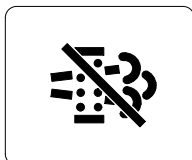

2609A3CD20

This warning lamp will light up when the exhaust system cleaning switch is pushed inhibit position.

- ※ Refer to page 3-9 for details.

(3) HEST (high exhaust system temperature) warning lamp

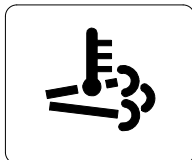

2609A3CD21

This warning lamp will light up when the exhaust temperatures are high due to exhaust system cleaning.

- ※ Refer to page 3-10 for details.

(4) Exhaust system cleaning switch

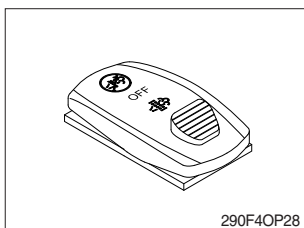

290F40P28

This switch is used to select the exhaust system cleaning.

- ※ If system conditions are not met, the exhaust system cleaning will not start.
- ※ Refer to page 3-42 for details.
- ※ Manual exhaust system cleaning : refer to page 3-10 for details.

CONTROL DEVICES

1. CAB DEVICES

1) The ergonomically designed console box and suspension type seat provide the operator with comfort.

2) ELECTRONIC MONITOR SYSTEM

- (1) The centralized electronic monitor system allows the status and conditions of the machine to be monitored at a glance.
- (2) It is equipped with a warning system for early detection of machine malfunction.

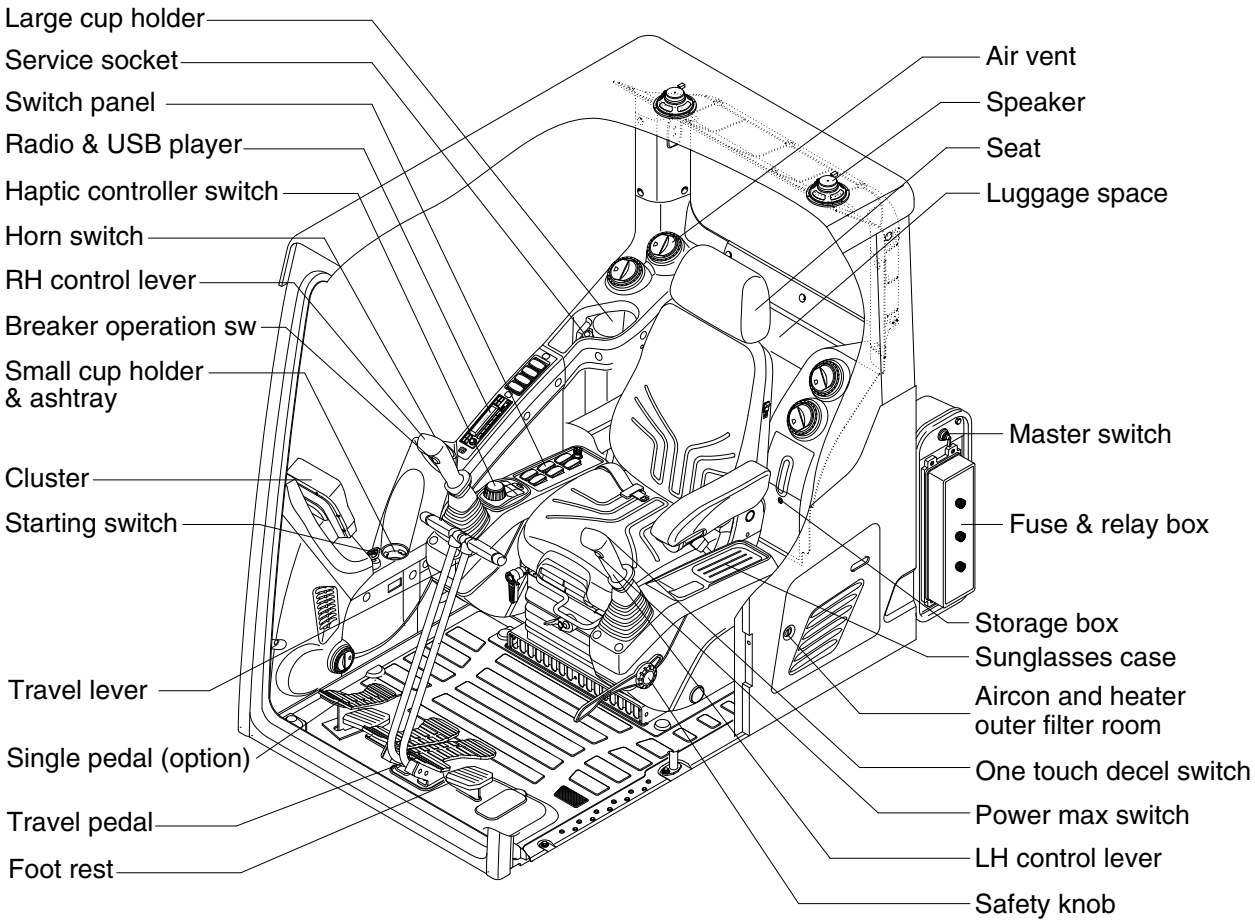

220A3CD01

2. CLUSTER

1) STRUCTURE

The cluster consists of LCD and switches as shown below. The LCD is to warn the operator in case of abnormal machine operation or conditions for the appropriate operation and inspection. The LCD is to set and display for modes, monitoring and utilities with the switches.

The switches or touch screen are to set the machine operation modes.

- ※ The cluster installed on this machine does not entirely guarantee the condition of the machine. Daily inspection should be performed according to chapter 6, Maintenance.
- ※ When the cluster provides a warning immediately check the problem, and perform the required action.



220A3CD20A

- ※ The warning lamp pops up and/or blinks and the buzzer sounds when the machine has a problem.

The warning lamp blinks until the problem is cleared. Refer to page 3-6 for details.

- ※ This cluster is adjustable.

- Vertical (forward/backward) : each 15°
- Horizontal (left only) : 8°

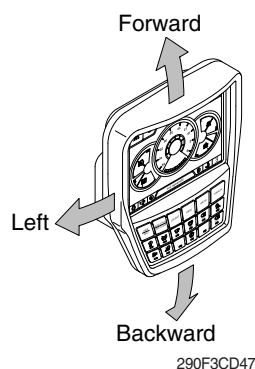

290F3CD47

2) GAUGE

(1) Operation screen

When you first turn starting switch ON, the operation screen will appear.



300A3CD21A

- | | | | |
|---|----------------------------------|---|-------------------------|
| 1 | RPM / Speed gauge | 5 | DEF/AdBlue® level gauge |
| 2 | Engine coolant temperature gauge | 6 | Tripmeter display |
| 3 | Hydraulic oil temperature gauge | 7 | Eco gauge |
| 4 | Fuel level gauge | 8 | Accel dial gauge |

(2) RPM / Speed gauge

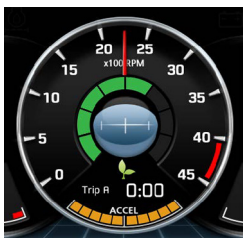



300A3CD22

- ① This displays the engine speed.

(3) Engine coolant temperature gauge





290F3CD53

- ① This gauge indicates the temperature of coolant.
- White range : 40-107°C (104-225°F)
 - Red range : Above 107°C (225°F)
- ② If the indicator is in the red range or  lamp pops up and the buzzer sounds, turn OFF the engine and check the engine cooling system.
- ※ If the gauge indicates the red range or  lamp blinks in red even though the machine is in the normal condition range, check the electric device as this can be caused by poor connection of sensor.

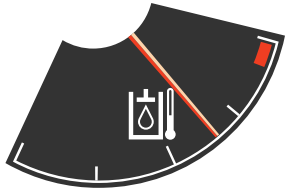
(4) Hydraulic oil temperature gauge





290F3CD54

- ① This gauge indicates the temperature of hydraulic oil.
 - White range : 40-105°C (104-221°F)
 - Red range : Above 105°C (221°F)
 - ② If the indicator is in the red range or  lamp pops up and the buzzer sounds reduce the load on the system. If the gauge stays in the red range, stop the machine and check the cause of the problem.
- ※ If the gauge indicates the red range or  lamp blinks in red even though the machine is in the normal condition range, check the electric device as this can be caused by poor connection of electricity or sensor.

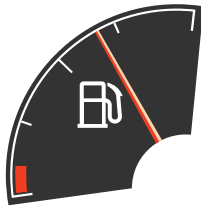
(5) Fuel level gauge





290F3CD55

- ① This gauge indicates the amount of fuel in the fuel tank.
 - ② Fill the fuel when in the red range, or  lamp pops up and the buzzer sounds.
- ※ If the gauge indicates the red range or  lamp blinks in red even though the machine is on the normal condition range, check the electric device as this can be caused by poor connection of electricity or sensor.

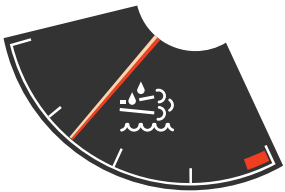
(6) DEF/AdBlue® Level gauge



290F3CD57

- ① This gauge indicates the amount of liquid in the DEF/AdBlue® tank.
 - ② Fill the DEF/AdBlue® when in the red range, or  lamp pops up and the buzzer sounds.
 - ③ Do not overfull DEF/AdBlue®.
- ※ Refer to page 3-11.
- ※ If the gauge indicates the red range or  lamp blinks in red even though the machine is in the normal condition range, check the electric device as this can be caused by poor connection of electricity or sensor.

(7) Tripmeter display

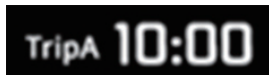

290F3CD56

- ① This displays the engine the tripmeter.
- ※ Refer to page 3-35 for details.

(8) Eco gauge



290F3CD58

- ① This gauge indicates the fuel consumption rate and machine load status so that the operators can operate the machine efficient in regards to fuel consumption.
- ② Fuel consumption rate or machine load is higher if the number of segments are increased.
- ③ The color of Eco gauge indicates operation status.
 - White : Idle operation
 - Green : Economy operation
 - Yellow : Non-economy operation at a medium level.
 - Red : Non-economy operation at a high level.

(9) Accel dial gauge



290F3CD59





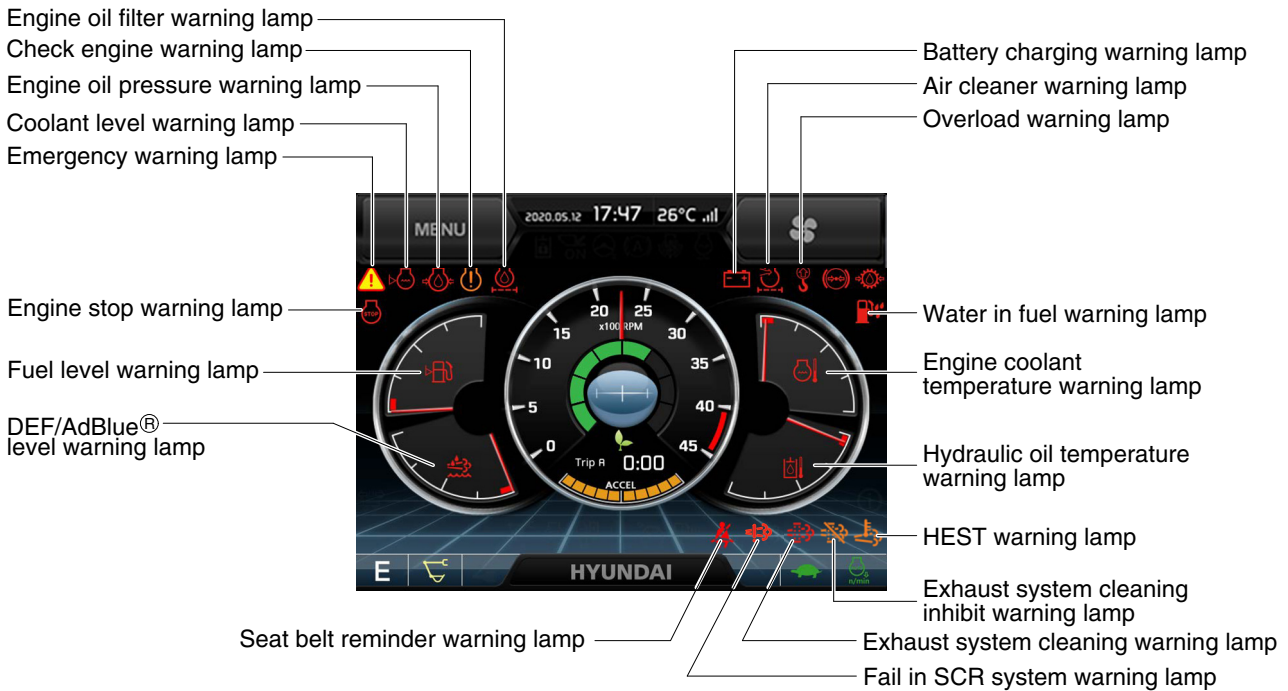





- ① This gauge indicates the level of accel dial.

3) WARNING LAMPS



300A3CD23B

※ Warning lamps and buzzer





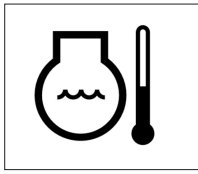

Warnings	When error happened	Lamps and buzzer
All warning lamps except below	Warning lamp pops up on the center of the LCD and the buzzer sounds	<ul style="list-style-type: none"> The pop-up warning lamp moves to the original position, blinks and the buzzer stops when; <ul style="list-style-type: none"> the buzzer stop switch  is pushed the knob of the jog dial module is pushed the lamp of the LCD is touched
	Warning lamp pops up on the center of the LCD and the buzzer sounds	<ul style="list-style-type: none"> The pop-up warning lamp moves to the original position, lights up or blinks and the buzzer stops when; <ul style="list-style-type: none"> the buzzer stop switch  is pushed the knob of the jog dial module is pushed the lamp of the LCD is touched <p>※ Refer to page 3-11 for details.</p>
  	Warning lamp pops up on the center of the LCD and the buzzer sounds	<ul style="list-style-type: none"> The pop-up warning lamp moves to the original position, lights up and the buzzer stops after 2 seconds elapses.
	Warning lamp pops up on the center of the LCD and the buzzer sounds	<ul style="list-style-type: none"> The pop-up warning lamp moves to the original position, blinks and the buzzer stops after 2 seconds elapses.
 	Warning lamp pops up on the center of the LCD and the buzzer sounds	<p>※ Refer to page 3-7 for details.</p>
	Warning lamp lights up and the buzzer sounds	<p>※ Refer to page 3-11 for details.</p>

※ Refer to page 3-17 for the buzzer stop switch  and page 3-65 for the jog dial module.

(1) Engine coolant temperature warning lamp







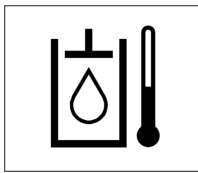

290F3CD61

- ① Engine coolant temperature warning is indicated in 2 steps.
 - 103°C over : The  lamp pops up and the buzzer sounds.
 - 107°C over : The  lamp pops up and the buzzer sounds.
- ② The pop-up ,  lamps move to the original position and blinks when the buzzer stop switch  is pushed. The buzzer will stop and ,  lamps will blink.
- ③ Check the cooling system when the lamps keep blinking.

(2) Hydraulic oil temperature warning lamp



290F3CD62

- ① Hydraulic oil temperature warning is indicated in 2 steps.
 - 100°C over : The  lamp pops up and the buzzer sounds.
 - 105°C over : The  lamp pops up and the buzzer sounds.
- ② The pop-up ,  lamps move to the original position and blinks when the buzzer stop switch  is pushed. The buzzer will stop and ,  lamps will blink.
- ③ Check the hydraulic oil level and hydraulic cooling system.

(3) Fuel level warning lamp

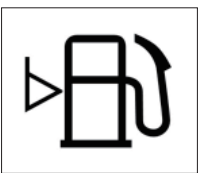

290F3CD63

- ① This warning lamp pops up and the buzzer sounds when the fuel level is below 55 ℓ (14.5 U.S. gal).
- ② Fill the fuel immediately after the lamp blinks.

(4) Emergency warning lamp



290F3CD64

- ① This warning lamp pops up and the buzzer sounds when each of the below warnings occurs.
 - Engine coolant overheating (over 107°C)
 - Hydraulic oil overheating (over 105°C)
 - MCU input voltage abnormal
 - Cluster communication data error
 - Engine ECM communication data error
- ※ The pop-up warning lamp moves to the original position and blinks when the buzzer stop switch  is pushed. The buzzer will stop.
- ② When this warning lamp blinks, machine must be checked and serviced immediately.

(5) Engine oil pressure warning lamp

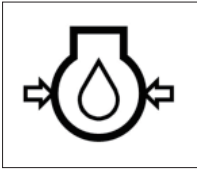

290F3CD65

- ① This warning lamp pops up and the buzzer sounds when the engine oil pressure is low.
- ② If the lamp lights up, shut OFF the engine immediately. Check oil level.

(6) Check engine warning lamp



290F3CD66

- ① This warning lamp pops up and the buzzer sounds when the communication between MCU and engine ECM is abnormal, or if the cluster received specific fault code from the engine ECM.
- ② Check the communication line between the two. If the communication line is OK, then check the fault codes on the cluster.

(7) Battery charging warning lamp

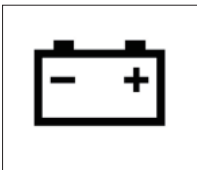

290F3CD67

- ① This warning lamp pops up and the buzzer sounds when the battery charging voltage is low.
- ② Check the battery charging circuit when this lamp blinks.

(8) Air cleaner warning lamp

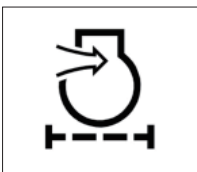

290F3CD68

- ① This warning lamp pops up and the buzzer sounds when the air cleaner is clogged.
- ② Check, clean or replace filter.

(9) Overload warning lamp (opt)

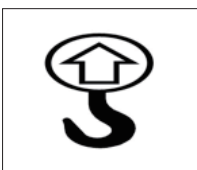

290F3CD69

- ① When the machine is overloaded, the overload warning lamp pops up and the buzzer sounds when the overload switch is ON. (if equipped)
- ② Reduce the machine load.

(10) Engine stop warning lamp



290F3CD252

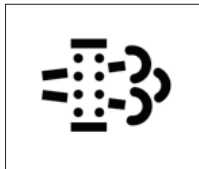

- ① This warning lamp pops up and the buzzer sounds after 30 minutes of run time elapses, when the DEF/AdBlue® tank has reached its minimum level. Stop engine immediately and check actual DEF/AdBlue® level.
- ② Fill the DEF/AdBlue® immediately.
※ Refer to page 3-11.
- ③ This lamp pops up and the buzzer sounds when the manual (stationary) exhaust system cleaning is not performed.
※ Refer to page 3-9.
※ Please contact your Hyundai service center or local dealer.
※ "Engine shutdown" cluster message pops up when the exhaust gas temperature reaches above 800°C.

(11) Exhaust system cleaning warning lamp



290F3CD70

- ① This warning lamp lights up or blinks when exhaust system cleaning is needed as seen in the table below.

Warning lamp			Description
Exhaust	Check engine	Stop engine	
			
Off	Off	Off	· Automatic exhaust system cleaning
Blink	Off	Off	· The status of a manual (stationary) exhaust system cleaning when the exhaust system cleaning switch has been activated. ※ Refer to page 3-10.
On	On	Off	· The aftertreatment exhaust system needs to be cleaned immediately. · Engine power will be reduced automatically if action is not taken. ※ The exhaust system cleaning can be accomplished by: - Changing to a more challenging duty cycle. - Performing a manual (stationary) exhaust system cleaning.
On	On	On	· These lamps will be ON when a manual (stationary) exhaust system cleaning is not performed. · Stop the engine immediately. · Please contact your Hyundai service center or local dealer.

(12) Exhaust system cleaning inhibit warning lamp

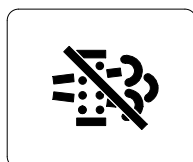

2609A3CD20

- ① This warning lamp indicates the exhaust system cleaning switch is pushed to the inhibit position, therefore automatic and manual exhaust system cleaning can not occur.
※ Refer to page 3-42 for the exhaust system cleaning switch.

※ Manual exhaust system cleaning

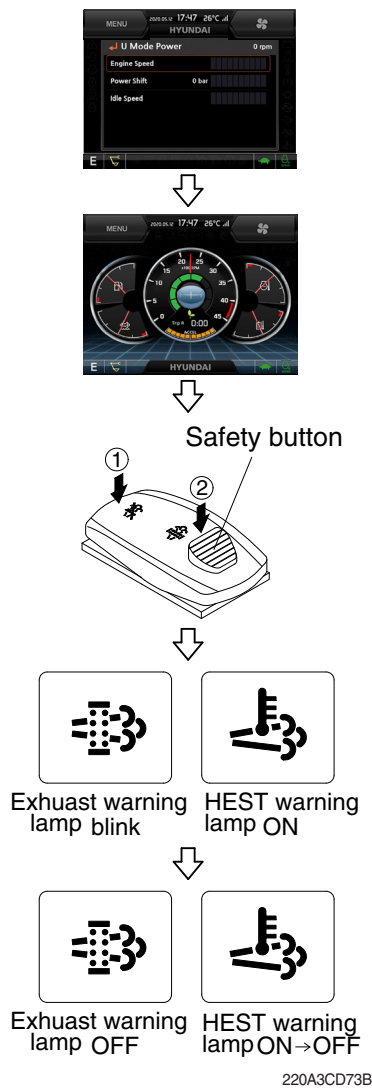

※ Manual exhaust system cleaning must be operated in a fireproof area.

※ To stop a manual exhaust system cleaning before it has completed, set to the exhaust system cleaning switch to the inhibit position or turn OFF the engine.

① Stop and park the machine.

② Pull the safety button and push the switch to position ② to initiate the manual exhaust system cleaning.

※ Refer to the page 3-42 for the exhaust system cleaning switch operation.

※ The engine speed may increase to 950~1050 rpm and exhaust system cleaning begins and it will take approximately 20~30 minutes.

③ The exhaust system cleaning warning lamp will blink and HEST warning lamp will light up during the exhaust system cleaning is operation.

④ The exhaust system cleaning and/or HEST warning lamp light will go off when the exhaust system cleaning is completed.

(13) HEST (High exhaust system temperature) warning lamp

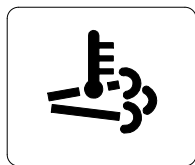

2609A3CD21

① This warning lamp indicates, when illuminated, that exhaust temperatures are high due to exhaust system cleaning.

② The lamp will also illuminate during a manual exhaust system cleaning.

③ When this lamp is illuminated, be sure the exhaust pipe outlet is not directed at any surface or material that can melt, burn, or explode.

▲ When this lamp is illuminated, the exhaust gas temperature could reach 800°C [1500°F], which is hot enough to ignite or melt common materials, and to burn people.

※ The lamp does not signify the need for any kind of equipment or engine service; It merely alerts the equipment operator to high exhaust temperatures. It is common for the lamp to illuminate on and off during normal equipment operation as the engine completes exhaust system cleaning cycles.

(14) DEF/AdBlue® level warning lamp



290F3CD257

- ① This warning lamp when ON or blinking, indicates that the DEF/AdBlue® level is low as per the table below.
- ※ It is recommended that the DEF/AdBlue® tank be filled completely full of the DEF/AdBlue® in order to correct any fault conditions.

Warning lamp				Description
Fail in SCR system	DEF/AdBlue® level	Check engine	Stop engine	
On	On	Off	Off	<ul style="list-style-type: none"> · The DEF/AdBlue® level has fallen below the initial warning level (10%).
On	On	On	Off	<ul style="list-style-type: none"> · The DEF/AdBlue® level has fallen below the initial derate level (2.5%). · The engine power will be limited automatically.
On	Blink	On	On	<ul style="list-style-type: none"> · This happens when 30 minutes has elapsed with empty conditions (0%) of the DEF/AdBlue® tank. · The engine will enter the final derate level which may include low idle lock or engine shutdown with restart limitations. · In order to remove the final derate, the DEF/AdBlue® tank must be filled to above 10% gauge reading.

(15) Water in fuel warning lamp



300A3CD24A

- ① This warning lamp lights up and the buzzer sounds when the water separator is full of water or malfunctioning.
- ※ When this lamp lights up, stop the machine and drain water from the separator.

(16) Seat belt reminder warning lamp



300A3CD25

- ① When operator does not fasten the operator's seat belt, the seat belt reminder warning lamp pops up and the buzzer sounds.
- ② Fasten the seat belt.

(17) Coolant level warning lamp

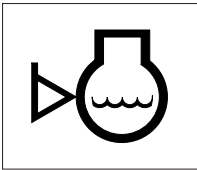

760F3CD58

- ① This warning lamp indicates lack of coolant.
- ② Check and refill coolant.

(18) Fail in SCR system warning lamp

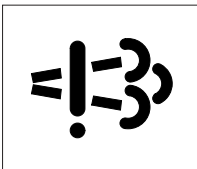

300A3CD15

- ① This warning lamp indicates there are faults related to SCR system.
 - ② The lamp lights up when each of the below warnings is happening.
 - a. Low DEF/AdBlue® level
 - b. Poor quality of DEF/AdBlue®
 - c. Tempering or malfunction in the aftertreatment system
 - ③ Once the lamp lights up, the engine will derate soon.
- ※ Please contact your Hyundai service center or local dealer.

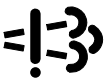
Warning lamp		Torque reduction
	Time	
On	Fault detected	-
On	After 2 h 30 min	· Torque is reduced to 75% of the highest torque.
Blink	After 3 h 45 min	· Torque is reduced to 50% of the highest torque.
Blink rapidly	After 4 hours	· Torque is reduced to 0% (low idling) of the highest torque within 2~10 min.

- ※ If a new fault occurs within 40 hours of operation since the first fault, the warning lamp will come ON. After 3 hours of operation, the warning lamp will blink rapidly and torque will be reduced to 0% (low idling) within 2~10 min.
- ※ Once the fault has been remedied and the engine control unit has received an indication that it is working, torque returns to the normal level.

(19) Engine oil filter warning lamp

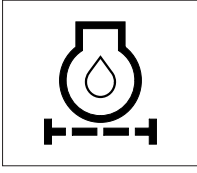

300A3CD306

- ① This warning lamp pops up and the buzzer sounds when the engine oil filter is clogged.
- ② Check the filter and clean or replace it.

4) PILOT LAMPS

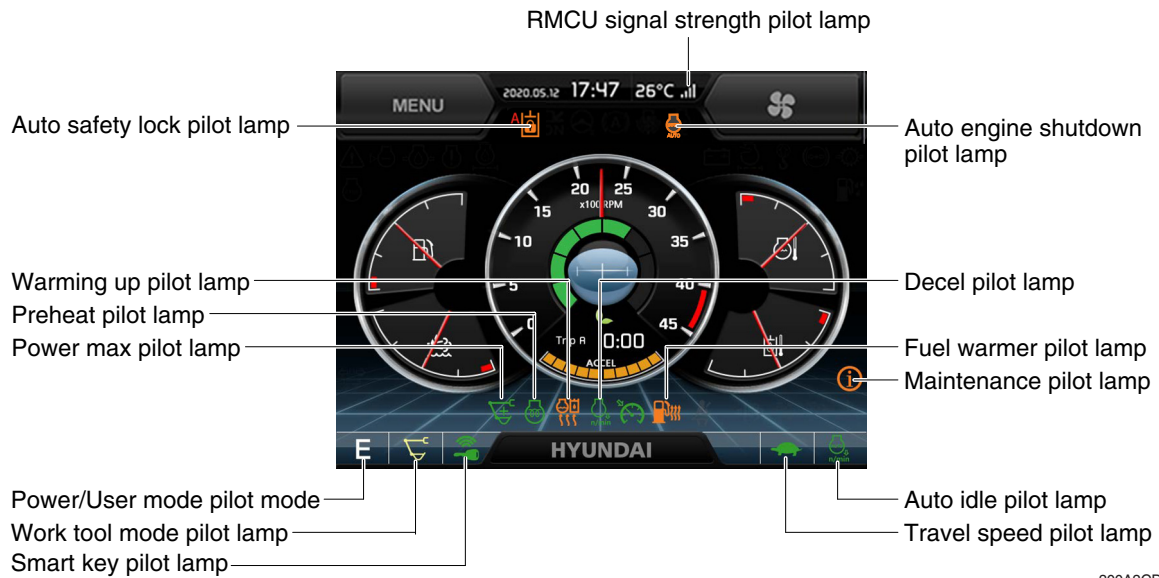

300A3CD26A

(1) Mode pilot lamps

No	Mode	Pilot lamp	Selected mode
1	Power mode		Heavy duty power work mode
			Standard power mode
			Economy power mode
2	User mode		User preferable power mode
3	Work tool mode		General operation - IPC speed mode
			General operation - IPC balance mode
			General operation - IPC efficiency mode
			Breaker operation mode
			Crusher operation mode
			Lifting mode
4	Travel mode		Low speed traveling
			High speed traveling
5	Auto idle mode		Auto idle

(2) Power max pilot lamp



300A3CD32

- ① The lamp will be ON when pushing power max switch on the LH RCV lever.
 - ② The power max function operates for a max period of 8 seconds.
- ※ Refer to the page 3-43 for power max function.

(3) Preheat pilot lamp

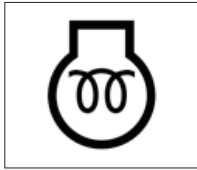

290F3CD79

- ① Turning the start key switch to the ON position starts preheating in cold weather.
- ② Start the engine after this lamp goes OFF.

(4) Warming up pilot lamp

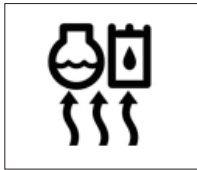

290F3CD80

- ① This lamp lights up when the coolant temperature is below 30°C (86°F).
- ② The automatic warming up is cancelled when the engine coolant temperature is above 30°C (86°F), or when 10 minutes have passed since starting the engine.

(5) Decel pilot lamp

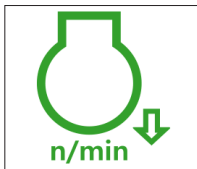

300A3CD33

- ① Operating one touch decel switch on the RCV lever makes the lamp light up.
 - ② Also, the lamp will light up and engine speed will be reduced automatically to save fuel when all levers and pedals are in the neutral position, and the auto idle function is selected.
- ※ **One touch decel is not available when the auto idle pilot lamp is turned ON.**
- ※ **Refer to the page 3-45.**

(6) Fuel warmer pilot lamp

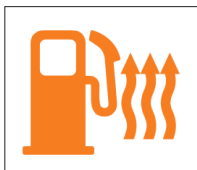

300A3CD34

- ① This lamp lights up when the coolant temperature is below 10°C (50°F) or the hydraulic oil temperature is 20°C (68°F).
- ② The automatic fuel warming is cancelled when the engine coolant temperature is above 60°C (140°F), and the hydraulic oil temperature is above 45°C (113°F) since the start switch was ON position.

(7) Maintenance pilot lamp



300A3CD35





- ① This lamp lights up when consumable parts are in need of replacement. It means that the change or replacement interval of parts is 30 hours from the required change interval.
 - ② Check the message in maintenance information of main menu. Also, this lamp lights up for 3 minutes when the start switch is switched to the ON position.
- ※ **Refer to page 3-28.**

(8) RMCU signal strength pilot lamp (mobile only)



220A3CD200

① This lamp indicates RMCU signal strength as below.

-  : Searching
-  : Bad
-  : Normal
-  : Good
-  : Excellent

(9) Smart key pilot lamp (opt)



300A3CD36A

① This lamp lights up when the engine is started by the start button.
② ton.

This lamp is red when the authentication fails, it will be green when authentication is successful.

※ Refer to the page 3-29.

(10) Auto safety lock pilot lamp



300A3CD37A

① Auto safety lock system prevents unintended operation of the machine in order to improve safety.

② Engine will only start if safety knob is locked.

③ If operator unlocks safety knob when RCV lever is pressed, machine is not controlled by RCV lever.

⚠ If operator unlocks safety knob while any control/function is being operated, the machine will move violently. This could cause serious injury, death or damage to property.

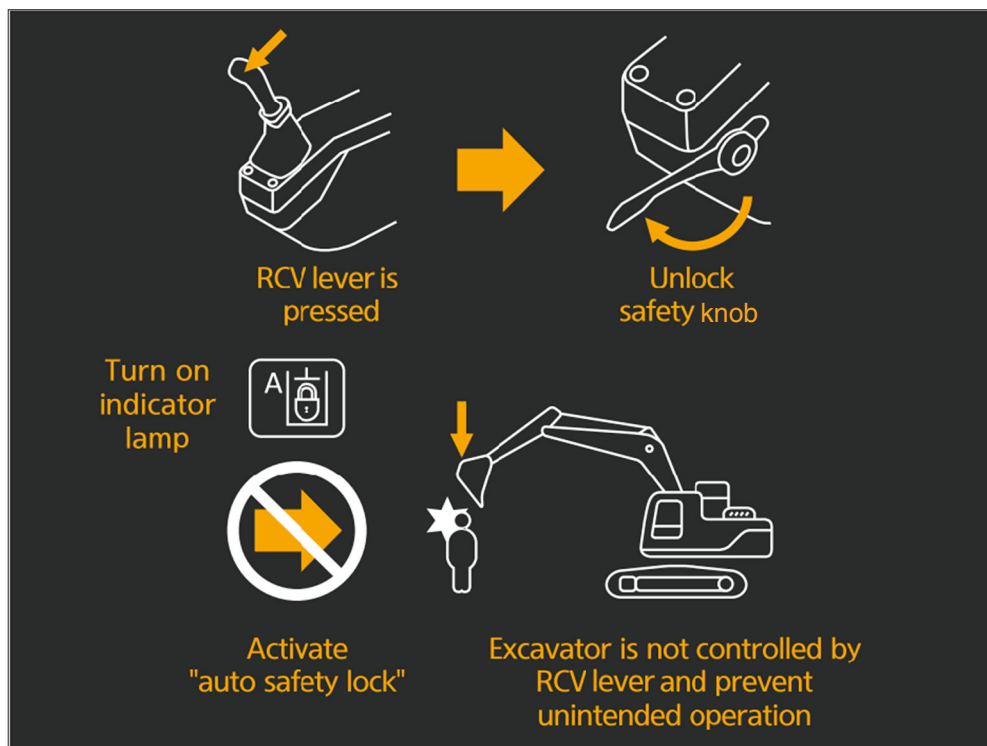

(11) Auto engine shutdown pilot lamp



220A3CD202A

① This lamp is turned ON when the auto engine shutdown is activated.

※ Refer to the page 3-24.

5) SWITCHES



300A3CD39A

※ When some of the switches are selected, the pilot lamps are displayed on the LCD. Refer to the page 3-13 for details.

(1) Power mode switch

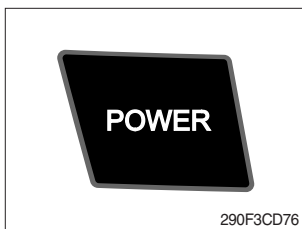

- This switch is to select the machine power mode and when pressed, the power mode pilot lamp will be displayed on the section of the monitor.
 - P : Heavy duty power work.
 - S : Standard power work.
 - E : Economy power work.
- The pilot lamp changes E → S → P → E in this order.

(2) Work mode switch

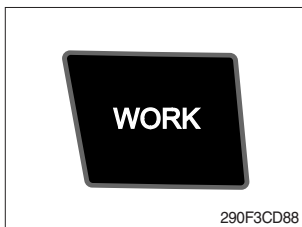

- This switch is to select the machine work mode, which shifts from general operation mode to optional attachment operation mode.
 - : General operation mode
 - : Breaker operation mode (if equipped)
 - : Crusher operation mode (if equipped)
 - : Lifting mode
 - Not installed : Breaker or crusher is not installed.

※ Refer to the page 2-7 for details.

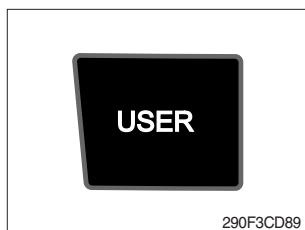

(3) User mode switch



- ① This switch is used to memorize the current machine operating status in the MCU and activate the memorized user mode.
 - Memory : Push more than 2 seconds.
 - Action : Push within 2 seconds.
 - Cancel : Push this switch once more within 2 seconds.
- ② Refer to the page 3-21 for another set of user mode.

(4) Travel speed switch



- ① This switch is used to select the travel speed alternatively.
 -  : Low speed
 -  : High speed

※ Do not change the setting of the travel speed switch while machine is moving. Machine stability may be adversely affected.

▲ Serious injury or death can result from sudden changes in machine stability.

(5) Auto idle/ buzzer stop switch



- ① This switch is used to activate or cancel the auto idle function.
 - Pilot lamp ON : Auto idle function is activated.
 - Pilot lamp OFF : Auto idle function is cancelled.
- ② The buzzer sounds when the machine has a problem. In this case, push this switch and buzzer stops, but the warning lamp blinks until the problem is cleared.

(6) Escape/Camera switch

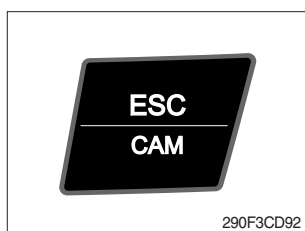

- ① This switch is used to return to the previous menu or parent menu.
- ② In the operation screen, pushing this switch will display the view of the camera on the machine (if equipped). Please refer to page 3-35 for the camera.
- ③ If the camera is not installed, this switch is used only ESC function.

(7) Work light switch

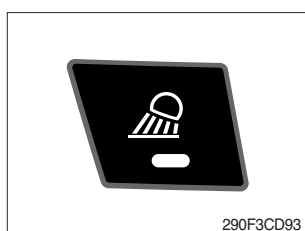

- ① This switch is used to operate the work light.
- ② The pilot lamp lights up when this switch is pressed.

(8) Head light switch



- ① This switch is used to operate the head light.
- ② The pilot lamp lights up when this switch is pressed.

(9) Intermittent wiper switch



- ① When this switch is pressed, wipers operate intermittently.
- ② The pilot lamp lights up when this switch is pressed.

(10) Wiper switch



- ① This switch is used to operate the wiper.
- ② Note that the wiper will self-park when switched off.
- ③ The pilot lamp lights up when this switch is pressed.
- △ **If the wiper does not operate with the switch in ON position, turn the switch OFF immediately. Check the cause. If the switch remains ON, motor failure can result.**

(11) Washer switch

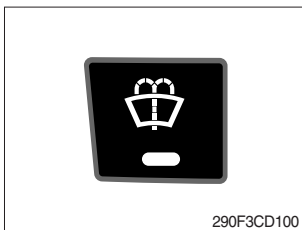

- ① Washer fluid is sprayed and the wiper is operated only when this switch is pressed.
- ② The pilot lamp lights up when this switch is pressed.

(12) Cab light switch

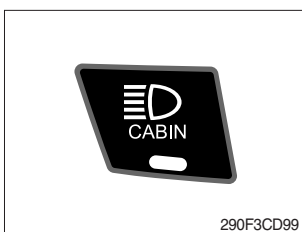

- ① This switch turns on the cab light.
- ② The pilot lamp lights up when this switch is pressed.

(13) Beacon switch (opt)

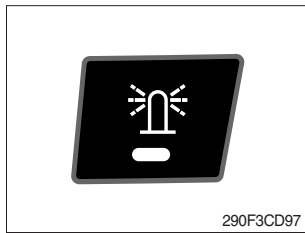

- ① This switch activates the rotary light on the cab.
- ② The pilot lamp lights up when this switch is pressed.

(14) Overload switch (opt)

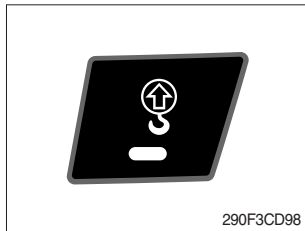

- ① When this switch is activated, buzzer makes sound and overload warning lamp lights up in the event that the machine is or becomes in an overloaded situation.
- ② When the switch is inactivated, buzzer stops and warning lamp goes off.

▲ Overloading the machine could impact the machines stability which could result in tipover hazard. A tipover hazard could result in serious injury or death. Always activate the overload warning device before you handle or lift objects.

(15) Travel alarm switch

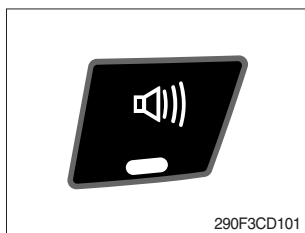

- ① This switch is to activate travel alarm function surrounding when the machine travels forward and backward.
- ② After activating this switch, the alarm operates only when the machine is traveling.
- ③ The pilot lamp lights up when this switch is pressed.

(16) Air conditioner quick touch switch

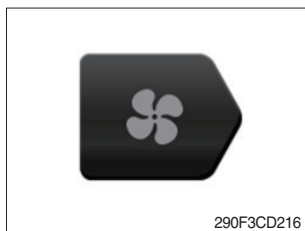

- ① This switch used to select air conditioner control mode.
- ※ Refer to page 3-37.

(17) Main menu quick touch switch



- ① This switch is to activate the main menu in the cluster.
- ※ Refer to page 3-20.

6) MAIN MENU

※ You can select or set the menu by the jog dial module or touch screen.

On the operation screen, tap MENU to access the main menu screen.

On the sub menu screen, you can tap the menu bar to access functions or applications.

· Operation screen

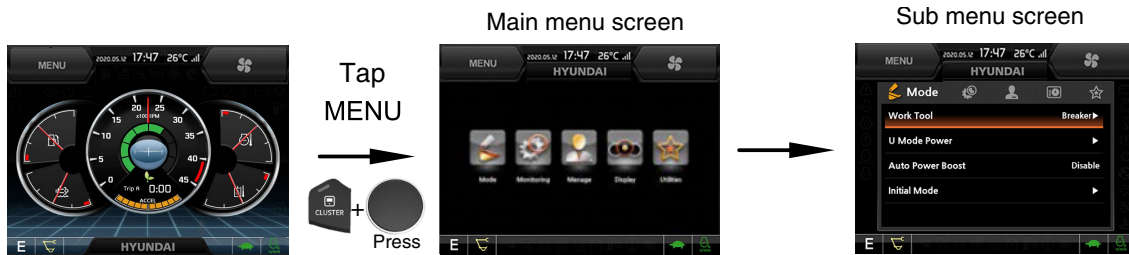

300A3CD40A

※ Please refer to the jog dial module, page 3-66 for selection and change of menu and input value.

(1) Structure

No	Main menu	Sub menu	Description
1	 Mode 290F3CD103	Work tool U mode power Combination speed setting Auto power boost IPC mode Auto engine shutdown Initial mode Emergency mode	Breaker, Crusher, Lifting Mode, Not installed User mode only Load sensitivity, Trucking balance, Boom/Arm balance, Arm speed Enable, Disable Speed mode, Balance mode, Efficiency mode One time, Always, Disable Key on initial mode / initial work mode, Accel initial mode / step Switch function
2	 Monitoring 290F3CD104	Active fault Logged fault Delete logged fault Monitoring	MCU, Engine ECM, Air conditioner, AAVM (option) MCU, Engine ECM, Air conditioner, AAVM (option) All logged fault delete, Initialization canceled Machine information, Switch status, Output status,
3	 Management 290F3CD105	Fuel rate information Maintenance information Machine security Machine information Contact Service menu Clinometer Update	General record, Hourly, Daily, Mode record Replacement, Change interval oils and filters ESL mode setting, Password change Model, MCU, Monitor, jog dial module, switch controller, RMCU, Relay drive unit, FATC, AAVM (option) A/S phone number, A/S phone number change Power shift, Operating hour, Breaker mode pump acting, EPPR current level, Overload pressure Clinometer setting Cluster, ETC device
4	 Display 290F3CD106	Display item Clock Brightness Unit setup Language selection	Engine speed, Tripmeter A, Tripmeter B, Tripmeter C Clock Manual, Auto Temperature, Pressure, Flow, Distance, Date format Korean, English, ETC
5	 Utilities 290F3CD107	Tripmeter Camera	3 kinds (A, B, C) Camera setting, Auto mode (travel)

(2) Mode setup

① Work tool

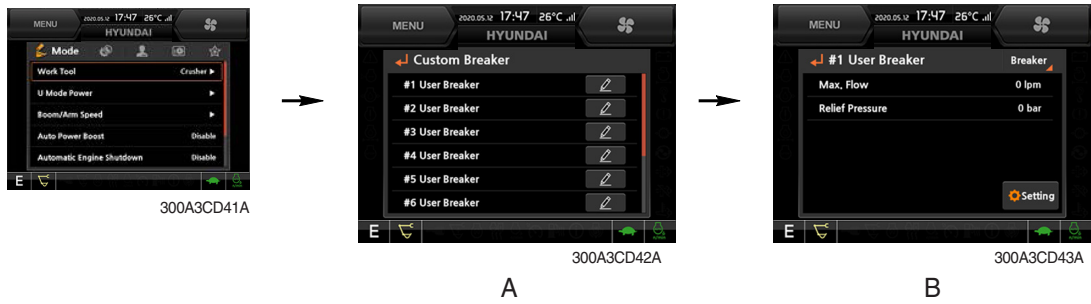

- Select installed optional attachment
 - A : It can set the user's attachment.
It is available in setting #1~#10.
 - B : Max flow - Set the maximum flow for the attachment.
Relief pressure - Set the relief pressure.

② U mode power

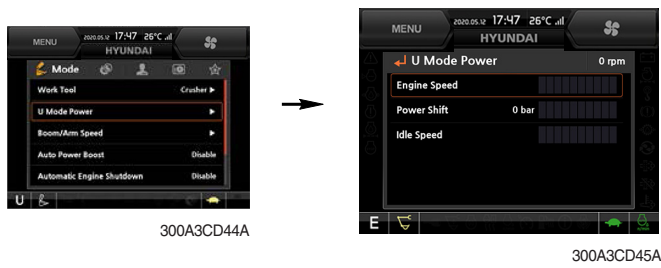

- Engine high idle rpm, auto idle rpm and pump torque (power shift) can be modulated and memorized separately in U-mode.
- U-mode can be activated by user mode switch.

Step (■)	Engine speed (rpm)	Idle speed (rpm)
1	1300	750
2	1400	800
3	1500	850
4	1600	900
5	1700	950
6	1800	1000 (auto decel)
7	1850	1050
8	1900	1100
9	1950	1150
10	2000	1200

※ One touch decel & low idle : 850 rpm

③ Combination speed setting

· Load sensitivity

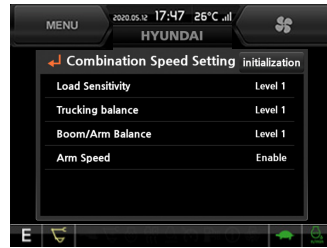

- The segment is close to low, the load sensitivity is decreased.
- The segments are close to high, the load sensitivity is increased.

⚠ Be careful of sudden movements when you choose "high load" but actual load isn't high.

· Trucking balance

This is control the swing and boom up speed when the combined operation is activated.

- The segment is close to swing, the swing speed has a priority.
- The segments are close to boom, the boom up speed has a priority.



· Boom / Arm balance

This is control the boom up and arm in speed when the combined operation is activated.

- The segment is close to arm, the arm in speed has a priority.
- The segments are close to boom, the boom up speed has a priority.

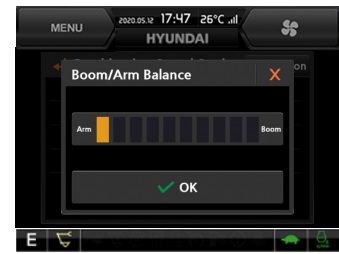

· Arm speed

Arm regeneration function can be activated or cancelled.

- Enable - Arm in speed is up.
- Disable - Normal operation.

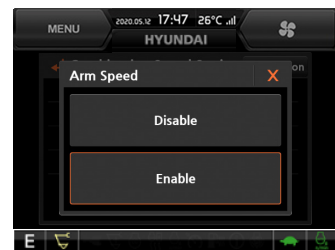

④ Auto power boost

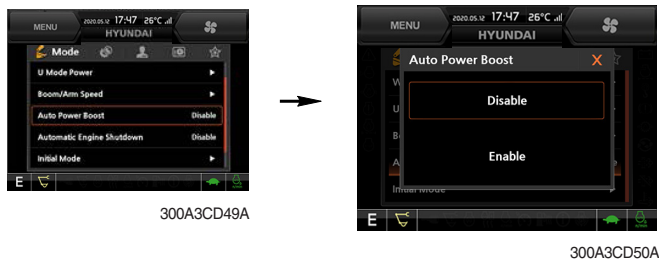

- The power boost function can be activated or cancelled.
 - Enable - The digging power is automatically increased as working conditions by the MCU. It is operated max 8 seconds, then goes off for a period of 1 second and then activates again for 8 seconds and continues this cycle.
 - Disable - Not operated.

⑤ IPC mode



- The IPC mode can be selected by this menu.
 - Speed mode
 - Balance mode (default)
 - Efficiency mode
- ※ Please update the cluster programs if this mode is not displayed in the mode setup menu. Refer to the page 3-31.

⑥ Automatic engine shutdown



- The automatic engine shutdown function can be set by this menu.
 - One time
 - Always
 - Disable
 - Wait time setting : Max 40 minutes, min 2 minutes

⑦ Initial mode



- **Key on initial mode**
 - Selected the power mode is activated when the engine is started.
- **Key on initial work mode**
 - Not installed
 - Last setting
 - Work mode
- **Accel initial mode**
 - Last setting value
 - User setting value
- **Accel initial step**
 - 0~9 step

⑧ Emergency mode



- This mode can be used when the switches are abnormal on the cluster.
- The cluster switches can be selected by touching each icon.

(3) Monitoring

① Active fault



- The active faults of the MCU, engine ECM, air conditioner or AAVM (option) can be checked by this menu.

② Logged fault

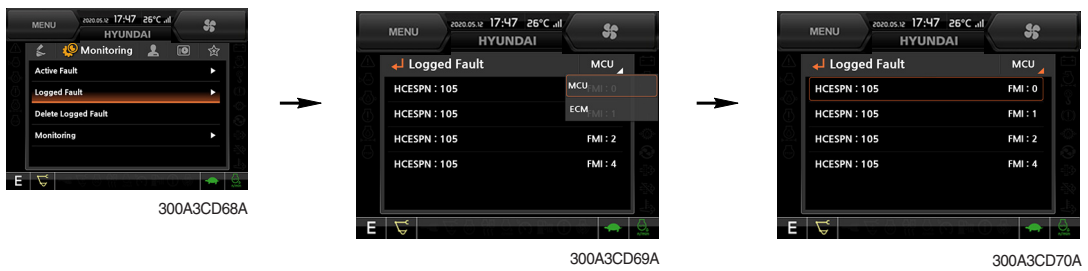

- The logged faults of the MCU, engine ECM, air conditioner or AAVM (option) can be checked by this menu.

③ Delete logged fault

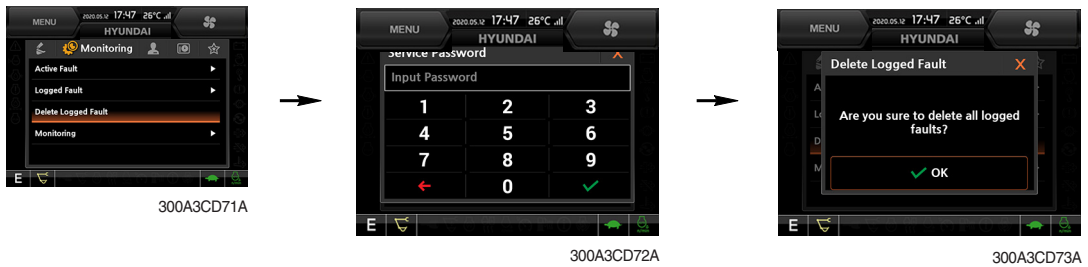

- The logged faults of the MCU, engine ECM, air conditioner or AAVM (option) can be deleted by this menu.

④ Monitoring

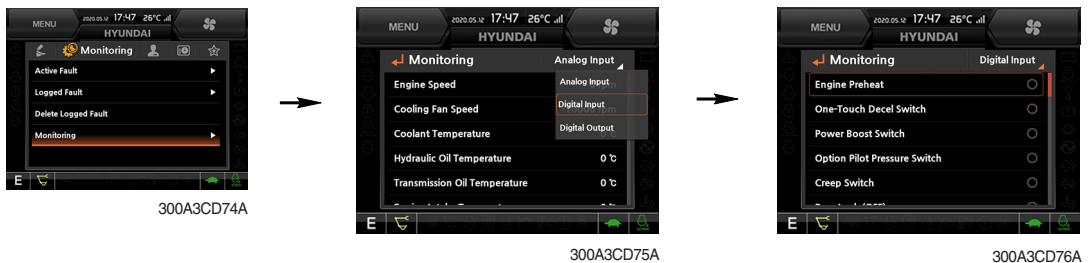

- The machine status such as the engine rpm, oil temperature, voltage and pressure etc. can be checked by this menu (Analog input).
- The switch status or output status can be confirmed by this menu (Digital input & Digital output).
- The activated switch or output pilot lamps ● will light up.

(4) Management

① ECO report

This reports the machine's inefficient operation status in order to improve operator's improper working habit.

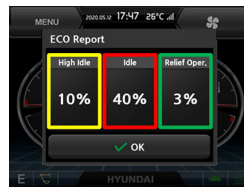

300A3CD77A

High idle



300A3CD78A

- Shows a breakdown of high idle, idle and relief operation when monitor is on.
- Gives a daily usage breakdown record for a 7 day period and an overall accumulated record from the first operation.

Idle

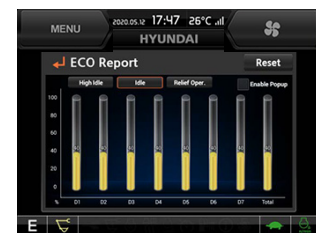

300A3CD79A

Relief operation



300A3CD80A

② Fuel rate information



A



B



C



D



· General record (A)

- Average fuel rate (left) (from "Reset" to now)
Fuel consumption divided by engine run time (service meter time).
- A days fuel used (right)
Fuel consumption from 24:00 (or "Reset" time) to now (MCU real time).

· Hourly record (B)

- Hourly fuel rates for past 12 hours (service meter time).
- No record during key-off time.
- One step shift to the right for every one hour.
- Automatic deletion of data from 12 hours and earlier.
- "Reset" deletes all hourly records.

· Daily record (C)

- Daily fuel consumption for past seven days (MCU real time).
- No record during key-off time.
- One step shift to the right at 24:00 for every day.
- Automatically deletes data from 7 days and earlier.
- All daily records deletion by "Reset".

· Mode record (D)

- Average fuel rate for each power mode/accel dial (at least 7) from "Reset" till present.
- No record during idle.
- All records can be deleted by "Reset".

③ Maintenance information

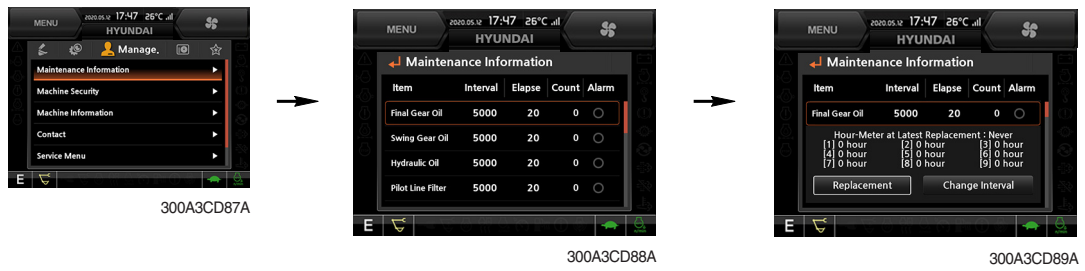

- Alarm lamp (●) is ON when oil or filter needs to be changed or replaced.
- Replacement : The elapsed time will be reset to zero (0).
- Change interval : The change intervals can be changed in hour increments of 50.
- ※ Refer to section, Maintenance chart for further information of maintenance interval.

④ Machine security



ESL mode setting

- ESL : Engine Starting Limit
- ESL mode is designed to be a theft deterrent or will prevent the unauthorized operation of the machine.
- When you Enable the ESL mode, the password will be required when the starting switch is turned to the on position.

- Machine security

Disable : ESL function is disabled and password is not required to start engine.

Enable (always) : The password is required whenever the operator starts engine.

- **Interval** : The password is required when the operator starts engine first. But the operator can restart the engine within the interval time without inputting the password. The interval time can be set to a maximum 4 hours.

※ **Default password** : 00000 + ✓

※ **Password length** : (5~10 digits) + ✓

- **Smart key** (option) : Smart key is registered when equipped with optional smart key. If smart key is not inside of the cabin, authentication process fails and the password is needed.

Password change

- The password is 5~10 digits.



※ **Before first use, please set user password and owner password in advance for machine security.**

⑤ Machine Information

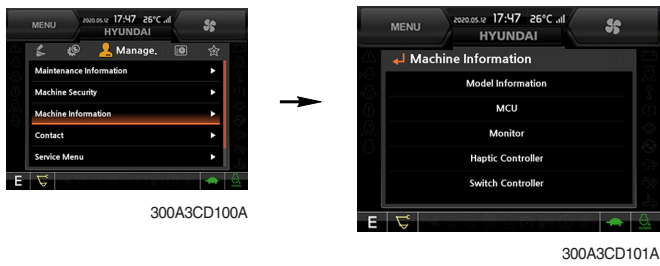

- This can confirm the identification of the model information (ECU), MCU, monitor, jog dial module, switch controller, RMCU, relay driver unit, FATC (air conditioner controller), AAVM (opt).

⑥ Contact (A/S phone number)



Enter the new A/S phone number

⑦ Service menu

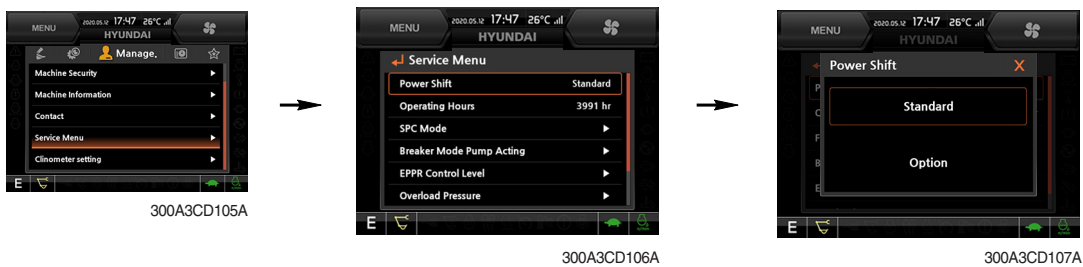

※ This menu can be used only HCE service man and can not be accessible by the owner and the operator.

- Power shift (standard/option) : Power shift pressure can be set by option menu.
- Operating hours : Operating hours since the machine line out can be checked by this menu.
- Breaker mode pump acting (1 pump/2 pump)
- EPPR current level (attach flow EPPR 1 & 2, boom priority EPPR, attach relief pressure EPPR 1 & 2)
- Overload pressure : 100 ~ 350 bar

⑧ Clinometer

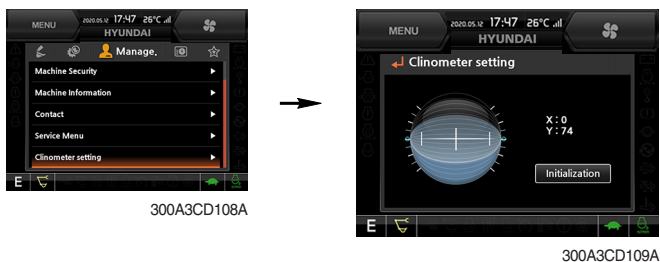

- When the machine is on the flatland, if you touch "initialization" on cluster, the values of X, Y will reset to "0".
- You can confirm tilt of machine in cluster's operating screen.

⑨ Update (cluster & ETC devices)

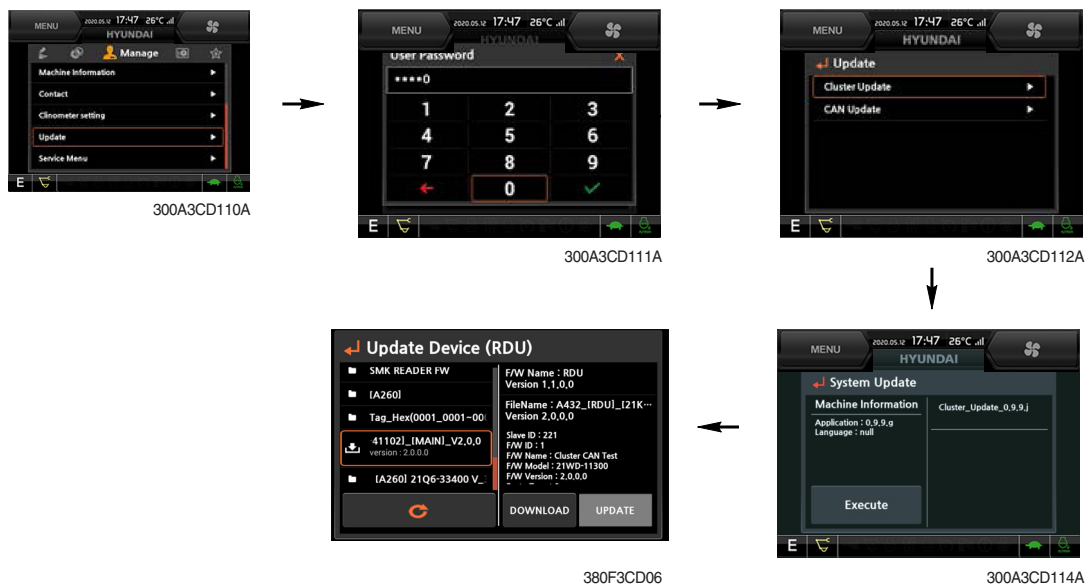

- ETC devices and cluster can be updated through CAN 2 network.
- Insert USB memory stick which includes program files, start download.

⑩ OME (owner menu editing)

The owner of machine can restrict operator access to set functions.

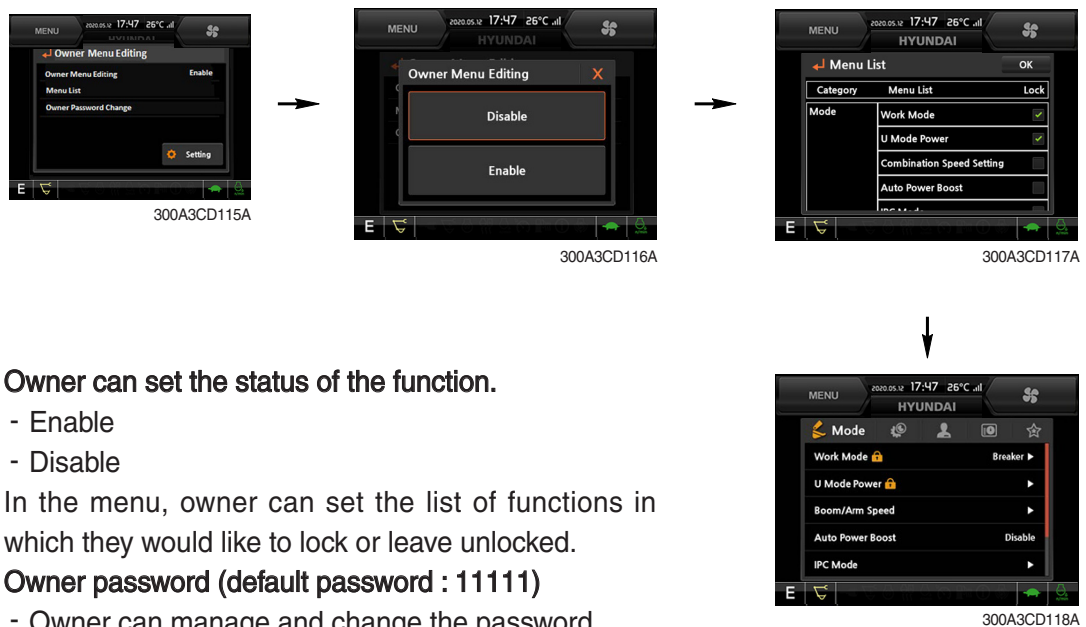

- **Owner can set the status of the function.**
 - Enable
 - Disable
- In the menu, owner can set the list of functions in which they would like to lock or leave unlocked.
- **Owner password (default password : 1111)**
 - Owner can manage and change the password.
 - Necessary to input the password to access functions menu.

- Password change
- The password is 5~10 digits.



※ Before first use, please set user password and owner password in advance for machine security.

(5) Display

① Display item



- The center display type of the LCD can be selected by this menu.
- The engine speed or the tripmeter menu (A,B,C) is displayed on the center display.

② Clock



- The first row of boxes indicate Year/Month/Day.
- The second row shows the current time. (0:00~23:59)

③ Brightness



- If "Auto" is chosen, brightness for day and night can be set accordingly. Also by using the bar in lower side, users can define which an operation interval belongs to day and night. (in bar figure, white area represents night time while orange shows day time)

④ Unit



- Temperature : °C ↔ °F
- Pressure : bar ↔ MPa ↔ kgf/cm²
- Volume : ℓ ↔ gal
- Flow : lpm ↔ gpm
- Distance : km ↔ mile
- Date format : yy/mm/dd ↔ mm/dd/yy ↔ dd-mm-yy

⑤ Language



- User can select preferable language and all displays are changed to the selected language.

(6) Utilities

① Tripmeter

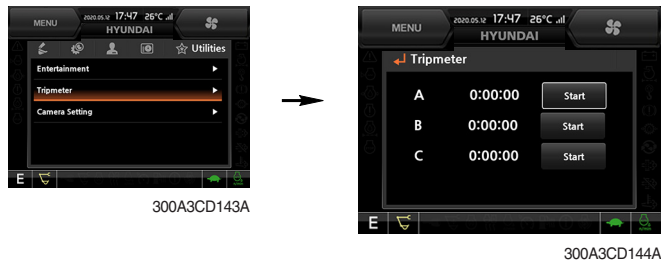

- A maximum of 3 types of tripmeters can be used at the same time.
- Each tripmeter can be turned on by choosing "Start". It can be turned off by choosing "Stop". If the tripmeter icon is activated in the operation screen, it can be controlled directly in this screen.

② Camera setting

- If the rear camera is not installed on the machine, set disable.
- If the rear camera is installed on the machine, set enable.



- Auto Mode (Travel) : Enable
The cluster will automatically shows camera view while machine is traveling.
- In the operation screen, rear camera screen show up when ESC/CAM switch is pushed.



③ **AAVM** (Advanced Around View Monitoring, option)

- The AAVM switches of the cluster consist of ESC/CAM and AUTO IDLE/Buzzer stop.



300A3CD149A

- **Escape switch**

- Activates AAVM mode from the beginning if AAVM is installed.
- While in the AAVM mode, select the ESC switch to return to the home screen.



300A3CD97A

Home screen



AAVM mode

235SA3CD222A

- **Buzzer stop switch**

- AAVM mode detects surrounding pedestrians or objects and the warning buzzer sounds.
- User can turn OFF the warning sound by pressing the buzzer stop switch.



220A3CD246

- When a worker/pedestrian reaches the green line, which is an external danger area equipped on the cluster, warning buzzer sounds and it displays a blue rectangular box recognizing the worker/pedestrian. Stop work immediately. Stop the buzzer by pressing the buzzer stop switch. Then resume work after you confirm that the area is safe and clear of workers/objects.



220A3CD247

- When a worker/pedestrian reaches the red line, which is an internal danger area equipped on the cluster, warning buzzer sounds and it displays a red rectangular box recognizing the worker/pedestrian. Stop work immediately. Stop the buzzer by pressing the buzzer stop switch. Then resume work after you confirm that the area is safe and clear of workers/objects.

▲ Failure to comply may result in serious injury or death.

※ In AAVM mode, a touch screen of the LCD is available only. The multimodal dial of the jog dial module is not available.

7) AIR CONDITIONER AND HEATER

Full auto air conditioner and heater system automatically keeps the optimum condition in accordance with operator's temperature configuration, sensing ambient and cabin inside temperature.

· Location of air flow ducts

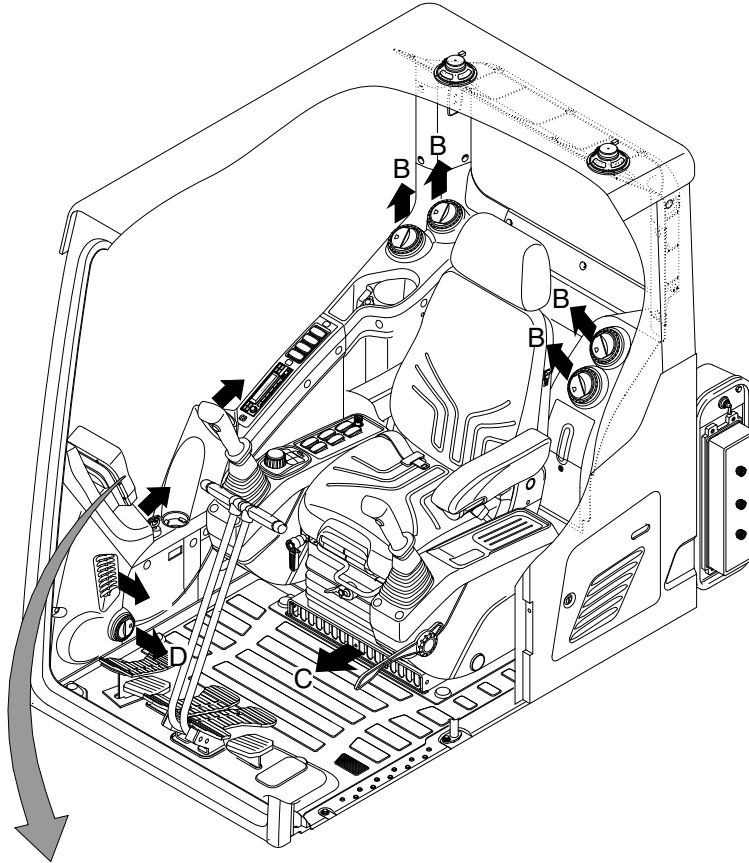

Cluster LCD



Cluster :  or

Jog dial module : 

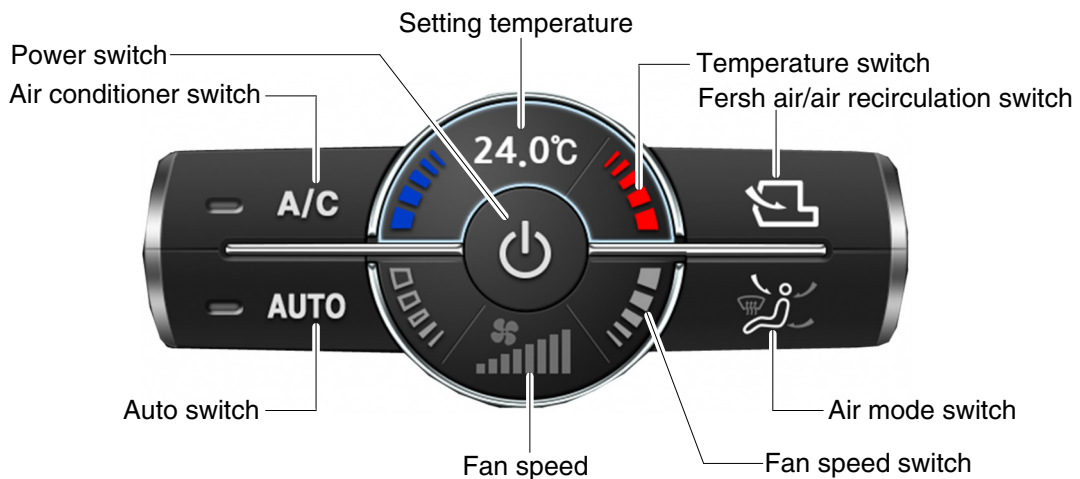

※ Jog dial module : Refer to page 3-66.

220A3CD21A

(1) Power switch



- ① This switch turns the system ON and OFF.
Just before powering OFF, set values are stored.
- ② Default setting values

Function	Air conditioner	In/outlet	LCD	Temperature	Mode
Value	OFF	Inlet	OFF	Previous sw OFF	Previous sw OFF

(2) Air conditioner switch



- ① This switch turns the compressor ON/OFF.
- ※ **Air conditioner operates to remove vapor and drains water through a drain hose. Water can be sprayed into the cab in case that the drain cock at the ending point of drain hose has a problem.**
In this case, exchange the drain cock.

(3) Auto switch



- ① Auto air conditioner and heater system automatically keeps the optimum condition in accordance with operator's temperature configuration sensing ambient and cabin inside temperature.

(4) Setting temperature



- ① Displays the temperature setting.

(5) Temperature switch

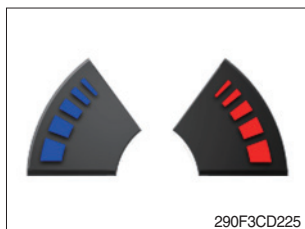

- ① Setting temperature indication
· Lo (17°C), 17.5~31.5°C, Hi (32°C)
- ② Max cool and max warm beeps 5 times.
- ③ The max cool or the max warm position operates per the following table.

Temperature	Compressor	Fan speed	In/outlet	Mode
Max cool	ON	Hi (8 step)	Recirculation	Face
Max warm	OFF	Hi (7 step)	Fresh	Def/Foot

- ④ Temperature unit can be changed between celsius (°C) and fahrenheit (°F)
 - a. Default status (°C)
 - b. The temperature unit can be changed (°C ↔ °F) by pressing temperature switches (Up/Down) simultaneously for more than 5 seconds.

(6) Fan speed switch

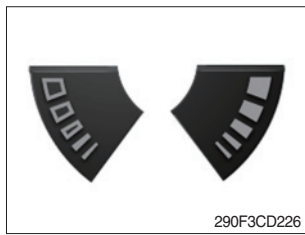

- ① Fan speed is controlled automatically by set temperature.
- ② This switch controls fan speed manually.
 - There are 8 up/down steps to control fan speed.
 - The maximum step or the minimum step beeps 5 times.

(7) Fan speed

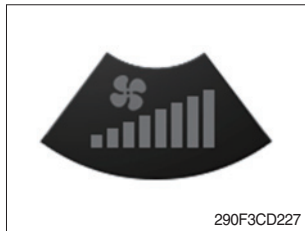

- ① Steps 1 through 8 to display the amount of air being circulated.

(8) Fresh air/air recirculation switch



- ① It is possible to change the air-inlet method.
 - a. **Fresh air** (🌬️)
Inhaling air from the outside.
 - b. **Air recirculation** (♻️)
It recycles the heated or cooled air to increase the energy efficiency.
 - ※ **Change air occasionally when using recirculation for a long periods of time.**
 - ※ **Check condition of an outer filter and an inner filter periodically to maintain good efficiency of the system.**

(9) Air mode switch



- ① Operating this switch, it beeps and displays symbol of each mode in the following order. (Face → Face/Rear → Face/Rear/Foot → Foot → Def/Foot)

Mode switch	Face	Face/Rear	Face/Rear/Foot	Foot	Def/Foot
Outlet	A	●	●	●	
	B		●	●	
	C			●	●
	D				●

- ② When operating defroster, FRESH AIR/AIR RECIRCULATION switch turns to FRESH AIR mode and air conditioner switch turns ON.

(10) Self diagnosis function

- ① Diagnostic methods : Diagnostic information window, select
- ② Diagnostic indication (Displays fault)

Fault code	Description	Fail safe function
F01	Ambient temperature sensor open	20°C alternate value control
F02	Ambient temperature sensor short	
F03	Cab inside temperature sensor open	25°C alternate value control
F04	Cab inside temperature sensor short	
F05	Evaporate temperature sensor open	0°C alternate value control
F06	Evaporate temperature sensor short	
F07	Null	-
F08	Null	-
F09	Mode 1 actuator open/short	The alternate value is face
F10	Mode 1 actuator drive circuit malfunction	If not, the alternate value is Def/Foot
F11	Intake actuator open/short	The alternate value is air recirculation
F12	Intake actuator drive circuit malfunction	The alternate fresh air
F13	Temperature actuator open/short	If opening amount is 0 %, the alternate value is 0 %
F14	Temperature actuator drive circuit malfunction	If not, the alternate value is 100 %
F15	Null	-
F16	Null	-

3. SWITCHES

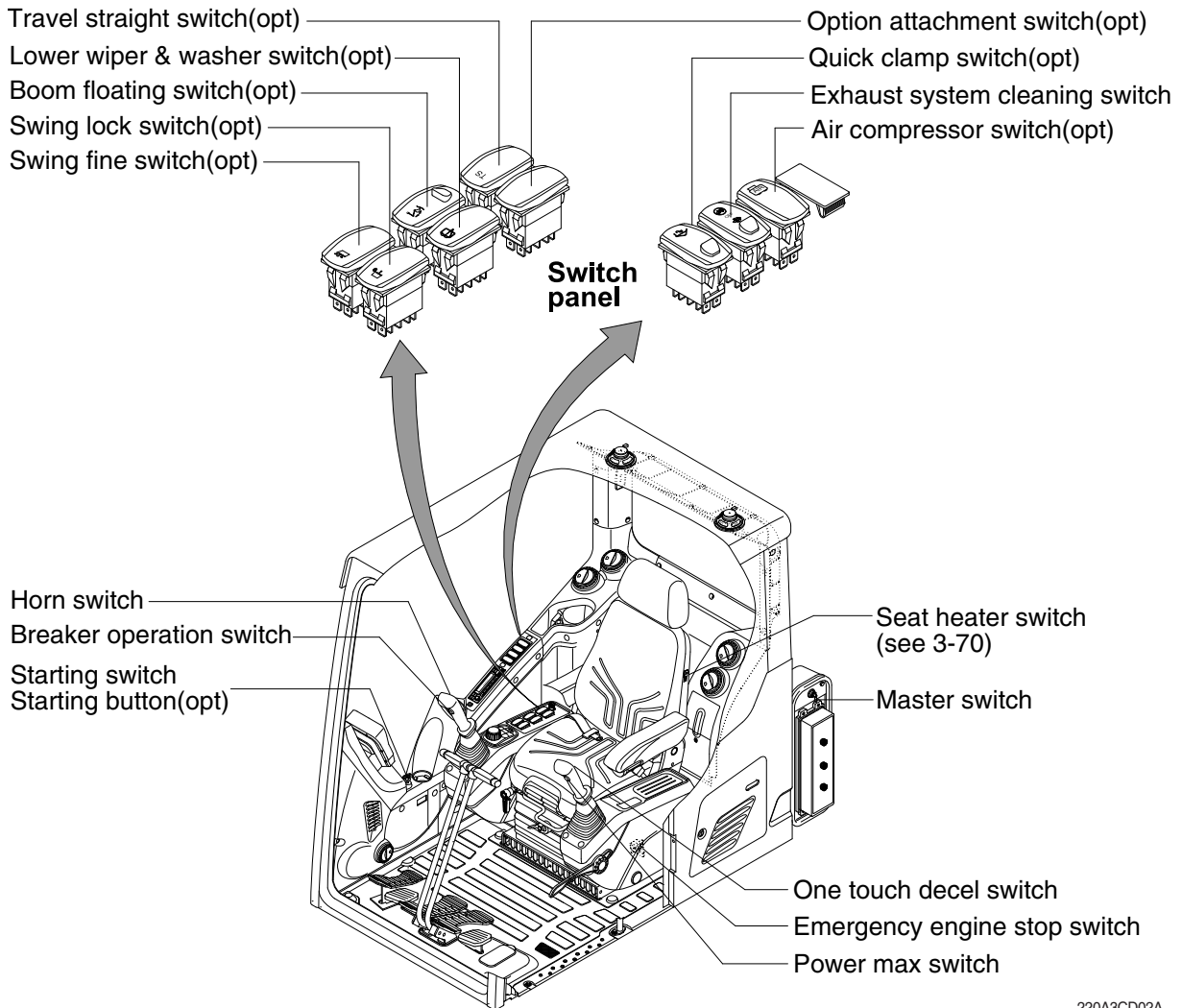

220A3CD02A

1) STARTING SWITCH & STARTING BUTTON (OPT)

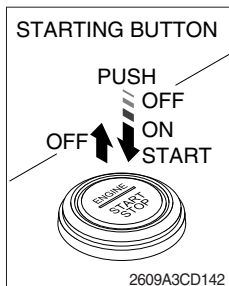
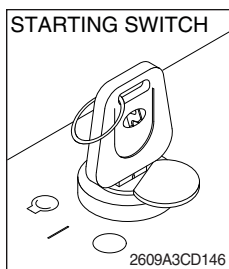

Starting button with smart key tag (opt)

(1) There are three positions, OFF, ON and START.

- ○ (OFF) : No of electrical circuits activate.
- | (ON) : All the systems of machine operate.
- ◯ (START) : Use when starting the engine.

Release key immediately after starting.

- ※ If you turn ON the starting switch in cold weather, the fuel warmer is automatically operated to heat the fuel by sensing the coolant temperature. Start the engine in 1~2 minutes after turning ON the starting switch. More time may be required according to ambient temperature.
- ※ Key must be in the ON position with engine running to maintain electrical and hydraulic function and prevent serious machine damage.

2) MASTER SWITCH

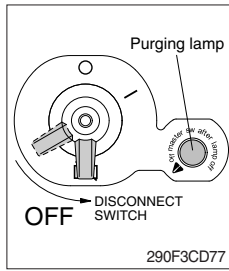

- (1) This switch is used to shut off the entire electrical system.
 - (2) I : The battery remains connected to the electrical system.
O : The battery is disconnected from the electrical system.
- ※ **Never turn the master switch to O (OFF) with the engine running. Engine and electrical system damage could result.**
 - ※ **Turn OFF the master switch after purging lamp goes OFF.**

3) QUICK CLAMP SWITCH (option)

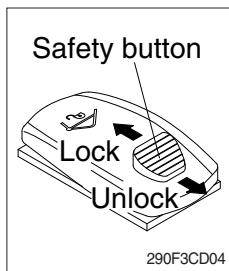

- (1) This switch is used to engage or disengage the moving hook on quick clamp.
- ※ **Refer to the page 8-6 for details.**

4) EXHAUST SYSTEM CLEANING SWITCH

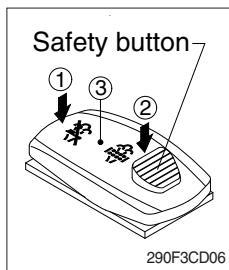

- (1) This switch is used to select the exhaust system cleaning.
- (2) **Inhibit position (①)**
 - ① The inhibit position disallows any automatic or manual exhaust system cleaning.
 - ② This may be used by operator to prevent exhaust system cleaning when the machine is operating in a hazardous environment and is concerned about high exhaust temperatures.
 - ③ It is strongly recommended that this position is only activated when high temperatures may cause a hazardous condition.
- (3) **Auto position (③)**

This position will initiate an automatic exhaust system cleaning.
- (4) **Manual position (②)**
 - ① This position will only initiate a manual exhaust system cleaning when the machine is in non-mission condition, engine must run at low idle speed and exhaust system levels are high enough to allow cleaning.
 - ② HEST lamp will be illuminated during the entire exhaust system cleaning.
 - ※ **Refer to the page 3-10 for details.**
 - ※ **This switch can be moved to the manual position (②) only when the safety button is pulled backward.**
 - ※ **Also, this switch returns to the auto position when released from the manual position (②).**

5) AIR COMPRESSOR SWITCH (option)

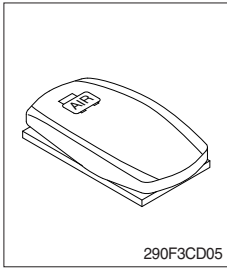

- (1) This switch is used to activate the air compressor.
- (2) The indicator lamp lights up when this switch is activated.

6) LOWER WIPER AND WASHER SWITCH (option)

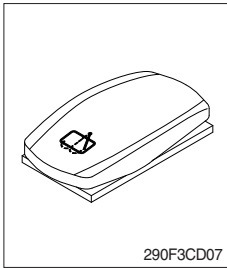

- (1) The washer fluid is sprayed and the wiper is operated only while pressing this switch.
- (2) The pilot lamp lights up when this switch is activated.

7) BOOM FLOATING SWITCH (option)

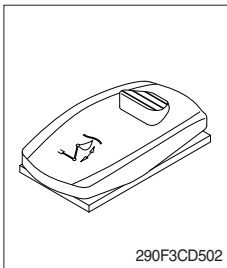

- (1) This mode is used to smooth boom operation.
- (2) Rod and head of boom cylinder are connected to the tank at the same time. This allows boom to move across the contour of the ground, through arm operation.

8) SWING LOCK SWITCH (option)

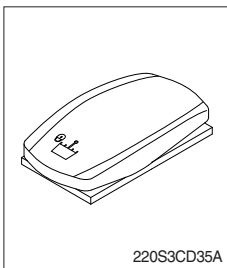

- (1) This switch is used to lock the swing parking brake.
- (2) Swing control is not available when this switch is activated.

9) FINE SWING SWITCH (option)

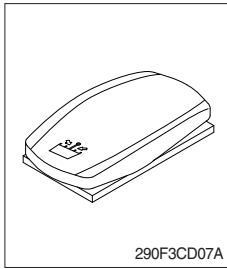

(1) When the switch is pressed to the ON position, the fine swing valve is operated and swing parking brake is released with below condition.

① Swing lever operated

Enhanced soft swing is implement to allow smooth start and stop.

② Boom up lever operated

Further control is possible by allowing free spins in lifting operation for offset loads.

③ Travel lever operated

Reduces the shaking of an object that is lifted.

▲ If the machine is operating on a slope with the switch in the ON position, swing motion may become uncontrollable which could result in property damage, serious injury or death. Do not select ON position when the machine is operating on a slope.

10) TRAVEL STRAIGHT SWITCH (option)

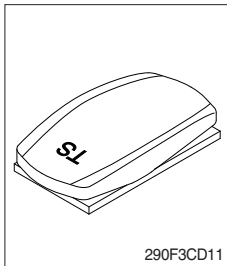

(1) When the travel straight switch is in the ON position, the machine will travel straight by use of only one travel pedal or lever.

11) HORN SWITCH

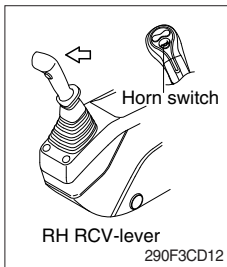

(1) This switch is at the top right side control lever. When pressed, the horn will sound.

12) BREAKER OPERATION SWITCH

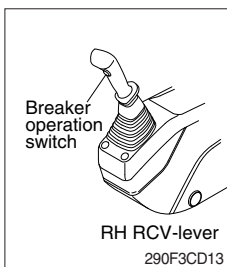

(1) When this switch is pressed, the breaker will only operate when the breaker operation mode is selected.

13) ONE TOUCH DECEL SWITCH

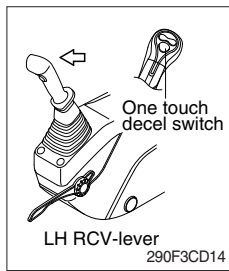

- (1) This switch is used to actuate the deceleration function quickly.
- (2) The engine speed is increased to previous setting value by pressing the switch again.
- (3) One touch decel function is available only when the auto idle pilot lamp is turned OFF.

14) POWER MAX SWITCH

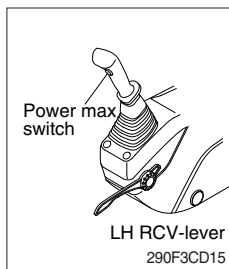

- (1) This switch activates power max function.
When this switch is pressed and held, hydraulic power of work equipment will be increased to approx 110 percent for a period of 8 seconds.
 - (2) After 8 seconds, function is cancelled automatically even if the switch remains pressed.
- ※ **Do not use for craning purposes.**

15) EMERGENCY ENGINE STOP SWITCH

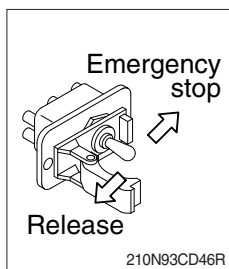

- (1) This switch is used to stop the engine in the event of an emergency.
※ **Be sure to return the emergency switch to the release or run position before trying to restart the engine.**

4. LEVERS AND PEDALS

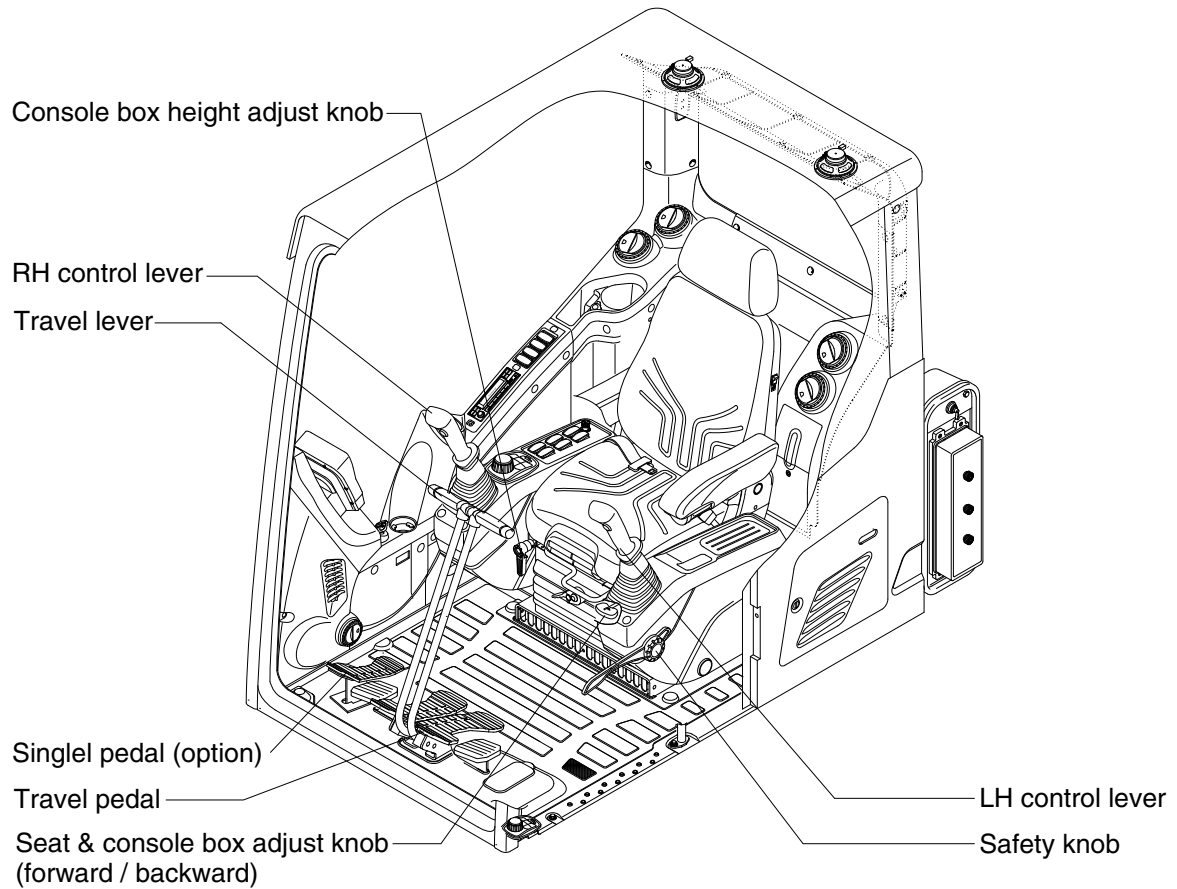

220A3CD16

1) LH CONTROL LEVER

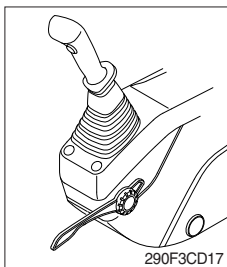

- (1) This joystick is used to control the swing and the arm.
- (2) Refer to operation of working device in chapter 2 for details.

2) RH CONTROL LEVER

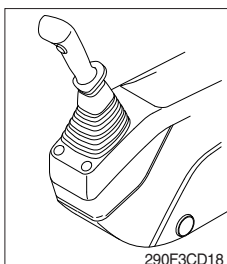

- (1) This joystick is used to control the boom and the bucket.
- (2) Refer to operation of working device in chapter 2 for details.

3) SAFETY KNOB

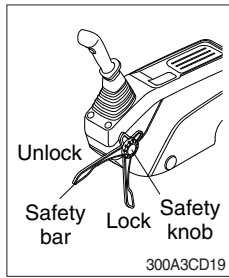

- (1) All control levers and pedals are disabled from operation by locating the safety knob to LOCK position as shown.
※ **Be sure to turn the safety knob to LOCK position when entering or leaving from operators seat/cabin.**
- (2) The machine is operational by turning the safety knob to UNLOCK position.
※ **Do not use the safety bar for handle when getting on or off the machine.**

4) TRAVEL LEVER

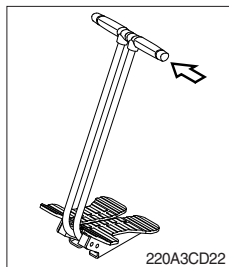

- (1) This lever is mounted on travel pedal and used for traveling by hand. The operation principle is same as the travel pedal.
- (2) Refer to traveling of the machine in chapter 2 for details.

5) TRAVEL PEDAL

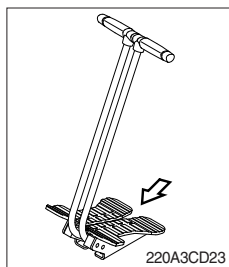

- (1) This pedal is used to move the machine forward or backward.
- (2) If left side pedal is pressed, left track will move.
If right side pedal is pressed, right track will move.
- (3) Refer to traveling of machine in chapter 2 for details.

6) SEAT AND CONSOLE BOX ADJUST KNOB (forward/backward)

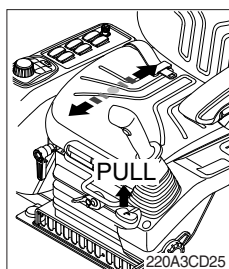

- (1) This knob is used to move the seat and console box to fit the contours of the operator's body.
- (2) Pull the knob to adjust forward or backward over 150 mm (5.9").

7) CONSOLE BOX (CONTROL LEVER) HEIGHT ADJUST KNOB

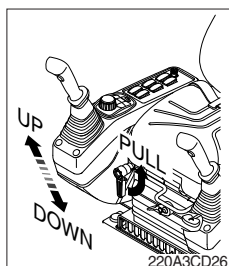

- (1) This knob is used to move the LH and RH control levers to fit the contours of the operator's body.
- (2) The control levers can be moved upward and downward at 45° over 80 mm (2.4").

8) SINGLE PEDAL (option)

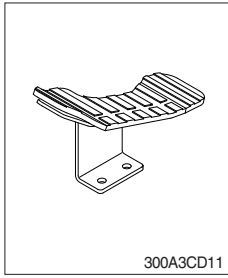

- (1) This pedal is used to operate the 2nd boom.
- (2) If the pedal is pushed front, the 2nd boom will be going down. And the pedal is pushed rear, the 2nd boom will be going up. Refer to operation of working device in chapter 2 for details.

5. OTHERS

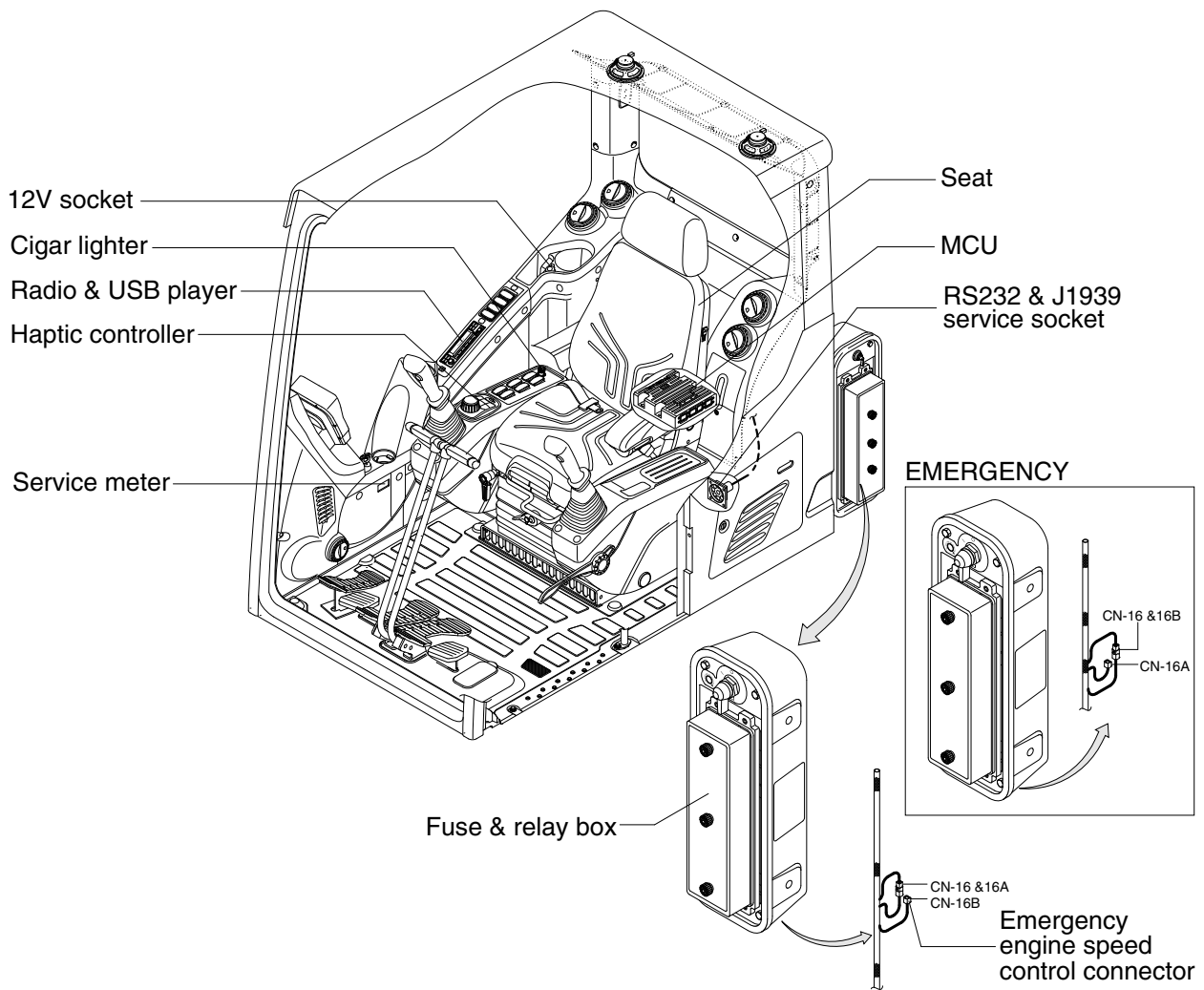

220A3CD24

1) CIGAR LIGHTER

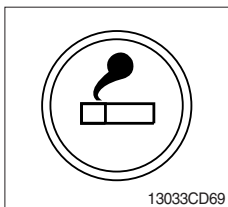

- (1) This can be used when the engine starting switch is ON.
- (2) The lighter can be used when it springs out in a short while after being pressed down.

※ **Service socket**

















**Use cigar lighter socket when you need emergency power.
Do not use the lighter exceeding 24 V, 100 W.**

2) RADIO AND USB PLAYER (WITH BLUETOOTH)



9403CD100

FRONT PANEL PRESENTATION

















- | | |
|---|---|
| <p>1  Power ON/OFF,
Volume UP/DOWN button</p> <p>2  Manual UP/DOWN Tuning,
File search, SEL button</p> <p>3  Mode button,
Audio mute button</p> <p>4  Call & Pair button</p> <p>5  Call end button</p> <p>6  Station preset 1
DIS Display button</p> <p>7  Station preset 2</p> <p>8  Station preset 3
RPT Repeat play button</p> <p>9  Station preset 4
RDM Random play button</p> | <p>10  Station preset 5
DIR- Directory down button</p> <p>11  Station preset 6
DIR+ Directory up button</p> <p>12  Scan play button (SCAN)
Best station memory (BSM) button</p> <p>13  Auto tune up, Seek up button</p> <p>14  Auto tune down, Track down button</p> <p>15  USB connector</p> <p>16  AUX IN Jack</p> <p>17  MIC hole</p> |
|---|---|

RADIO AND USB PLAYER (WITHOUT BLUETOOTH)



9403CD101

FRONT PANEL PRESENTATION

- | | |
|--|---|
| <p>1  Power ON/OFF,
Volume UP/DOWN button</p> <p>2  Manual UP/DOWN Tuning,
File search, SEL button</p> <p>3  Mode button,
Audio mute button</p> <p>4  Radio seek up button</p> <p>5  Radio seek down button</p> <p>6  Station preset 1
DIS Display button</p> <p>7  Station preset 2</p> <p>8  Station preset 3
RPT Repeat play button</p> <p>9  Station preset 4
RDM Random play button</p> | <p>10  Station preset 5
DIR- Directory down button</p> <p>11  Station preset 6
DIR+ Directory up button</p> <p>12  Scan play button (SCAN)
Best station memory (BSM) button</p> <p>13  Track up button</p> <p>14  Track down button</p> <p>15  USB connector</p> <p>16  AUX IN Jack</p> |
|--|---|

■ GENERAL

(1) Power and volume button



① Power ON / OFF button

Press power button (1) to turn the unit on or off.

② Volume UP/DOWN control knob

Turn VOL knob (1) right to increase the volume level.

Turn VOL knob (1) left to decrease the volume.

After 5 seconds the display will return to the previous display mode.

③ Initial volume level set up

I-VOL is the volume level the unit will play at when it is next turned on. To adjust the I-VOL level, press and hold VOL button (1) for longer than 2 seconds. The current volume level displays on the display panel.

Then turn button (1) right or left to set the volume level as the I-VOL level.

④ Clock ON/OFF control

The CLOCK was default at off status. To turn CLOCK ON, press and hold VOL button (1) for longer than 2 seconds to display I-VOL, then short press VOL again, turn VOL knob while CLOCK OFF display, then the CLOCK ON will be displayed.

※ Due to time tolerance, the clock display on the Audio unit might have slight difference.

⑤ Clock adjustment

With CLOCK ON selected, press VOL knob again after CLOCK ON display, the hour will blink, turn VOL knob right or left to adjust hour.

Simply press VOL again, the minute will blink, turn VOL knob to adjust minute. Then press VOL again to confirm the clock once finished.

(2) Menu Selection



- ① This button can adjust the effect of sound and other things.

Each time you press this button (2), LCD displays as follows :

BAS → TREB → BAL L=R → FAD F=R → EQ → LOUD ON →
BEEP 2ND

On each setting, the level can be controlled by turning TUNE knob (2). When the last adjustment is made, after 5 seconds, the display will automatically return to the previous display mode.

② Bass control

To adjust the bass tone level, first select the bass mode by pressing SEL button (2) repeatedly until BASS appears on the display panel. Then turn knob (2) right or left within 5 seconds to adjust the bass level as desired. The bass level will be shown on the display panel from a minimum of BASS-7 to a maximum of BASS+7.

③ Treble control

To adjust the treble tone level, first select the treble mode by pressing SEL button (2) repeatedly until TREB appears on the display panel. Then turn knob (2) right or left within 5 seconds to adjust the treble level as desired. The treble level will be shown on the display panel from a minimum of TREB -7 to a maximum of TREB +7.

④ Balance control

To adjust the left-right speaker balance, first select the balance mode by pressing SEL button (2) repeatedly until BAL indication appears on the display panel. Then turn knob (2) right or left within 5 seconds to adjust the balance as desired. The balance position will be shown by the bars on the display panel from BAL 10R (full right) to BAL 10L (full left).

⑤ Fader control

To adjust the front-rear speaker balance, first select the fader mode by pressing SEL button (2) repeatedly until FADER indication appears on the display panel. Then turn knob (2) right or left within 5 seconds to adjust the front-rear speaker level as desired. The fader position will be shown by the bars on the display panel from FAD 10F (full front) to FAD 10R (full rear).

⑥ EQ control

You can select an equalizer curve for 4 music types (CLASSIC, POP, ROCK, JAZZ). Press button (2) until EQ is displayed, then turn knob (2) right or left to select the desired equalizer curve. Each time you turn the knob, LCD displays as follows :

EQ OFF → CLASSIC → POP → ROCK → JAZZ

- ※ When the EQ mode is activated, the BASS and TREBLE modes are not displayed.

⑦ Loud control

When listening to music at low volume levels, this feature will boost the bass and treble response. This action will compensate for the reduction in bass and treble performance experienced at low volume.

To select the loudness feature, press button (2) until LOUD is displayed, then turn knob (2) right or left to activate or deactivate loudness.

⑧ Beep control

To adjust the BEEP mode, first select the BEEP mode by pressing button (2) repeatedly until BEEP indication appears on the display panel. Then turn knob (2) left or right within 5 seconds to select BEEP 2ND, BEEP OFF or BEEP ON.

- BEEP 2ND : You will only hear the beep sound when the buttons are held down for more than 2 seconds.
- BEEP OFF : You can not hear the sound beep when you press the buttons.
- BEEP ON : You can hear the beep sound each time you press the buttons.

(3) Mute control

- ① Press and hold MUTE button (3) for over 2 seconds to mute sound output and MUTE ON will blink on the LCD. Press the button again to cancel MUTE function and resume to normal playing mode.

(4) Mode selection

- ① Repeat press MODE button (3) to switch between FM1, FM2, AM, USB, AUX, BT MUSIC.
- ※ If there is no USB, AUX, Bluetooth Phone connected, it would not display USB, AUX, BT when you press button (3).

■ RADIO

(1) Mode button



- ① Repeat press MODE button to select FM1, FM2 or AM.

(2) Manual tuning button



- ① To manually tune to a radio station, simply turn encoder TUNE (2) left or right to increase or decrease the radio frequency.

(3) Auto tuning button



- ① To automatically select a radio station, simply press Seek up or Track down button.



(4) Station preset button



- ① In radio mode, pressing buttons (6) to (11) will recall the radio stations that are memorized. To store desired stations into any of the 6 preset memories, in either the AM or FM bands, use the following procedure :

- a. Select the desired station.
- b. Press and hold one of the preset buttons for more than 2 seconds to store the current station into preset memory. Six stations can be memorized on each of FM1, FM2, and AM.

(5) Preset scan (PS) / Best station memory (BSM) button

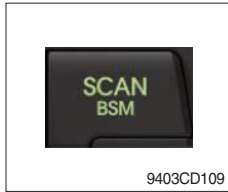

① Press BSM button (12) momentarily to scan the 6 preset stations stored in the selected band. When you hear your desired station, press it again to listen to it.

Press BSM button (12) for longer than 2 seconds to activate the Best Station Memory feature which will automatically scan and enter each station into memory.

※ **If you have already set the preset memories to your favorite stations, activating the BSM tuning feature will erase those stations and enter into the new ones. This BSM feature is most useful when travelling in a new area where you are not familiar with the local stations.**

■ USB PLAYER

(1) USB playback



- ① The unit was equipped with a front USB jack and also a rear USB Jack.

With a USB device plugged in the front USB jack, it will be detected as front USB mode. And with a USB device plugged in the rear USB jack, it will be detected as rear USB. To get to a USB mode, press MODE (3) button momentarily or insert the USB device in front or rear USB jack.

- ※ If there are no mp3 or wma files in USB device, it will revert to the previous mode after displaying NO FILE.

(2) Track Up / Down button



- ① Press SEEK up (13) or TRACK down (14) to select the next or previous track. Press and hold the buttons to advance the track rapidly in the forward or backward direction.



(3) MP3 directory / File searching



- ① Button (2) is used to select a particular directory and file in the device. Turn button (2) right or left to display the available directories. Press button (2) momentarily when the desired directory is displayed, then turn button (2) right or left again to display the tracks in that directory. Press button (2) to begin playback when the desired file is displayed.

(4) Directory Up / Down button



- ① During MP3/WMA playback, simply press DIR- button (10) to select the previous directory (if available in the device); simply press DIR+ button (11) to select the next directory (if available in the device).

- ※ If the USB device does not contain directories, it would play MP3/WMA tracks at 10- file when you press DIR- button (10), and play MP3/WMA tracks at 10+ file when you press DIR+ (11) button.

(5) Track Scan Play (SCAN) button

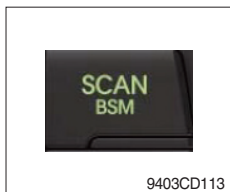

- SCAN playback : Simply press SCAN (12) button to play the first 10 seconds of each track.
- SCAN folder : Press and hold SCAN button for longer than 2 seconds to scan play the tracks in current folder.
- SCAN off : Simply press it again to cancel SCAN feature.

(6) Track Repeat Play (RPT) button



- REPEAT playback : Simply press RPT (8) button to play current track repeatedly.
- REPEAT folder : Press and hold RPT for longer than 2 seconds to repeat play the tracks in current folder.
- REPEAT off : Simply press it again to cancel REPEAT feature.

(7) Track Random Play (RDM) button



- RANDOM playback : Simply press RDM (9) button to play the tracks in the device in a random sequence.
- RANDOM folder : Press and hold RDM button for longer than 2 seconds to randomly play the tracks in the current folder.
- RANDOM off : Simply press it again to cancel RANDOM feature.

(8) ID3 v2 (DISP)



- ① While a MP3 file is playing, press DISP button (6) to display ID3 information. Repeat push DISP button (6) to show directory name / file name and album name / performer / title.

※ If the MP3 disc does not have any ID3 information, it will show NO ID3.

* USB Information and Notice

- a. Playback FILE SYSTEM and condition allowance.
 - FAT, FAT12, FAT16 and FAT32 in the file system.
 - V1.1, V2.2 and V2.3 in the TAG (ID3) version.
 - b. Display up to 32 characters in the LCD display.
 - c. No support any of MULTI-CARD Reader.
 - d. No high speed playback but only playing with normal full speed.
- ※ DRM files in the USB may cause malfunction to playback in the radio unit.
- ※ In temperatures below -10°C (14°F), the audio unit with USB hook up may be affected and not play well.

■AUX OPERATION

It is possible to connect your portable media player to the audio system for playback of the audio tracks via the cab speakers.

To get the best results when connecting the portable media to the audio system, follow these steps :

- Use a 3.5 mm stereo plug cable to connect the media player headphone socket at each end as follows.
 - Adjust the portable media player to approximately 3/4 volume and start playback.
 - Press the MODE button (3) on the audio unit to change into AUX mode.
 - The volume and tone can now be adjusted on the audio unit to the desired level.
- ※ The audio quality of your media player and the audio tracks on it may not be of the same sound quality as the audio system is CD Player.
- ※ If the sound of the media player is too low compared with the radio or CD, increase the volume of the player.
- ※ If the sound of the media player is too loud and/or distorted, decrease the volume of the player.
- ※ When in AUX mode, only the Volume, Bass, Treble, EQ and Mode functions of the audio unit can be used.

■ BLUETOOTH (if equipped)

(1) Using a bluetooth wireless connection

- ① Your audio unit supports bluetooth wireless technology. You can set up a wireless link with bluetooth cellular phone.
 - ② Continue to pair the cellular phone with the audio unit. Within a few moments the two should be able to connect.
- ※ Since this audio unit is on standby to connect with your cellular phone via bluetooth wireless technology, using this audio unit without running the engine can result in battery drainage.
 - ※ This audio units phone call reception is on standby when ignition switch is set to ACC OFF or ON.
 - ※ The line-of-sight distance between this audio unit and your cellular phone must be 10 meters or less for sending and receiving voice and data via bluetooth wireless technology. However the transmission distance may become shorter than the estimated distance depending on the environment where it is being used.
 - ※ Digital Noise & Echo suppression system provides the best sound clarity with little or no distortion (Echo & side tone will happen depending on cellular phone or service network).
 - ※ To ensure the quality of calling, you should select a proper bluetooth VR level. This audio unit is already equipped with the best bluetooth VR level.

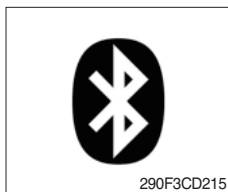

a. Bluetooth icon

It will blink while establishing the bluetooth pairing.
It will light up after a bluetooth device connected.

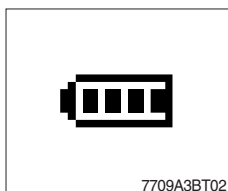

b. Battery icon

It indicates the battery status of the connected bluetooth device.



c. Single strength icon

It indicates the signal strength of the connected bluetooth device.

(2) Pairing in hands free modes



- ① Press and hold CALL button (4) for 2 seconds until you hear beep sound, then PAIR STR will appear on the display.
- ② For the next procedure, go to cellular phone pairing mode.
- ③ If it is in pairing status with audio unit and cellular phone, PAIRING will show on the display.
- ④ If you want to exit pairing mode, press CALL END button (5) briefly while pairing, then it will show PAIR CLR on the display.
- ⑤ Bluetooth Icon and PAIR OK appear on the display when pairing is successful.

(3) Cellular phone pairing mode

- ① Browse your cellular phone menu and find the connectivity or bluetooth connection section.
 - ② Select search for a new handsfree device function and allow the phone to find the mobile.
 - ③ HYUNDAI should appear on your cellular phone screen.
 - ④ Press connect menu among the handsfree option on your cellular phone.
 - ⑤ The cellular phone should prompt for a pin code. Insert the pin code 1234.
 - ⑥ The cellular phone should confirm that it has established a new paired connection.
 - ⑦ Close the menu. The pairing is now completed. It appears PAIR FAIL on the display for 3 seconds.
- ※ Each cellular phone type has distinct phone menu so you may need to refer to your manufactures instruction for the correct procedure on how to connect a new bluetooth device.
 - ※ Please retry the pairing instruction if HYUNDAI does not appear on the cellular phone screen.
 - ※ Please select authorized, if there is authorized menu in the menu of bluetooth connection in your cellular phone.
 - ※ Once the bluetooth pairing is completed between your cellular phone and this audio unit, both units will be automatically recognized on its paring like when you turn on the key in your car even though the audio unit is turned off.
 - ※ This audio unit can store up to 6 phones pairings. If the memory is full, the first stored paired phone will be deleted.
 - ※ The connecting priority will be given to the last connected cellular phone.
 - ※ If you want to change the connecting priority, try to connect this audio unit from the cellular phone you want.

(4) Bluetooth connection and disconnection



① When established bluetooth connection is made between this audio unit and the cellular phone, bluetooth icon on the display appears and then the display shows HF/AV CONN when handsfree & AV profile is connected.

② To disconnect bluetooth link
Press and hold CALL END button (5) for 2 seconds, it shows DIS CON and bluetooth Icon disappears on the display.

③ To connect bluetooth link
Press CALL button (4) briefly, it blinks bluetooth Icon on the display while bluetooth is being connected. If the connection is completed, bluetooth Icon displays on the display.

※ When your cellular phone battery is at low charge, the bluetooth connection may occasionally be lost. To maintain good connectivity ensure that your phone battery is adequately charged.

※ In case of failure of bluetooth pairing :

- Delete item in paired list on your phone.
- Reset both phone by power off/on and the audio unit by ACC off/on.

※ Connecting priority of handsfree profile is higher than headset profile.

※ The headset mode does not support caller ID, reject call and call Transfer.

(5) Using the audio unit as a handsfree device



① When the audio unit is ringing, it shows CALL and follows with the phone number ***** on the display.

② To accept call
Press CALL button (4), ANSWER CALL followed by TALKING will show in the display.

③ To end call
To end call, press CALL END button (5), REJECT appears on the display.

※ If reject call is activated in your phone, then your cellular phone does not support reject call function.

(6) Audio transfer between the audio unit and phone

The audio transfer function is for switching the call from the audio unit to the cellular phone for private conversation.



① Press CALL button (4) briefly during conversation, it appears CALL TRANS on the display. To switch back to the audio unit, press button (4) briefly during private conversation, then it appears CALL TRANS on the display again.

※ **This function will be a cause of disconnection of bluetooth link in some nokia phones, but do not worry, just press button (4) during private conversation, then switch back to the audio unit automatically.**

※ **The quality of calling between cellular phone and audio unit is better than calling between one audio unit and another one.**

(7) Last call number dialing



① Press CALL button (4) briefly, it appears CALL TO on the display, then simply press CALL button once again, it would make the last call with phone number displayed on LCD.

If Reject call is activated in your phone, then your cellular phone does not support Reject Call function.

※ **If you are using SAMSUNG phone, then you may need to press send button once more. With the first press of button it should show contact list in your phone, then if you press again you should be ready to make the last call.**

(8) To make a call by cellular phone

The audio transfer function is for switching the call from the audio unit to the cellular phone for private conversation.

- ① The audio unit will be activated automatically when you make a call with cellular phone.
- ② When you make a call processing by cellular phone, it shows CALLING on the display.
- ③ When you receive a call, the phone number ***** appears on the display.

(9) Using the audio unit as bluetooth music





The audio unit supports A2DP (Audio Advanced Distribution Profile) and AVRCP (Audio Video Remote Control Profile), and both profiles are available to listen music at the audio unit via cellular phone which is supporting the two profiles above.

- ① To play music, search the menu on your cellular phone as below :
i.e : Menu→ File manager→ Music→ Option→ Play via bluetooth.
It appears BT MP3 on the display.
 - ② During BT MP3 playing, you could select the previous or next track by pressing SEEK up or TRACK down button on audio unit or operate via your cellular phone.
 - ③ To stop music, press button (5) briefly and it will automatically switch into the previous mode.
 - ④ To resume music playing, press the play button on your cellular phone.
- ※ **This function may be different depending on cellular phone. Please follow the cellular phone menu. Some types of phones need to pair once more for bluetooth MP3 connection.**
 - ※ **This function will be caused to disconnect A2DP, AVRCP depends on cellular phone.**
 - ※ **Information about songs (e.g.: the elapsed playing time, song title, song index, etc.) cannot be displayed on this audio unit.**

■ RESET AND PRECAUTIONS

(1) Reset function

Interfering noise or abnormal compressed files in the MP3 disc or USB instrument may cause intermittent operation (or unit frozen/locking up). It is strongly recommended to use appropriate USB storage to not cause any malfunction to the audio unit. In the unlikely event that the player fails to operate correctly, try to reset unit by any of following two methods.

- ① press and hold   simultaneously for about 5 seconds. (without Bluetooth)
- ② Press and hold   simultaneously for about 5 seconds. (with Bluetooth)

※ Take out the fuse for the audio system in the vehicle once and then plug it back in.

※ It will be necessary to re-enter the radio preset memories as these will have been erased when the microprocessor was reset.

After resetting the player, ensure all functions are operating correctly.

(2) Precautions

When the inside of the cab is very cold and the player is used shortly after switching on the heater, moisture may form on the disc or the optical parts of the player and proper playback may not be possible.

If moisture forms on the optical parts of the player, do not use the player for about one hour. The condensation will disappear naturally allowing normal operation.

- ① Operation voltage : 9~32 volts DC, negative
- ② Output power : 40 watts maximum (20 watts x 2 channels)
- ③ Tuning range

Area	Band	Frequency range	Step
USA	FM	87.5~107.9 MHZ	200K
	AM	530~1710 KHZ	10K
EUROPE	FM	87.5~108.0 MHZ	50K
	AM	522~1620 KHZ	9K
ASIA	FM	87.5~108.0 MHZ	100K
	AM	531~1602 KHZ	9K
LATIN	FM	87.5~107.9 MHZ	100K
	AM	530~1710 KHZ	10K

● AREA Selection :

- To select an area, press and hold related buttons at FM1 band for about 3 seconds.
- USA Area: Press and hold mode + 1DIS buttons for 3 seconds
- EUROPE Area: Press and hold mode + 2 buttons for 3 seconds
- ASIA Area: Press and hold mode + 3RPT buttons for 3 seconds
- LATIN Area: Press and hold mode + 4RDM buttons for 3 seconds.

- ④ USB version : USB 1.1
- ⑤ Bluetooth version : V2.1
- ⑥ Bluetooth supported profile :
 - A2DP : Advanced Audio Distribution Profile
 - AVRCP : Audio/Video Remote Control Profile
 - HFP : Hands-Free Profile

3) JOG DIAL MODULE

The jog dial module consists of buttons, multimodal dial and USB port.

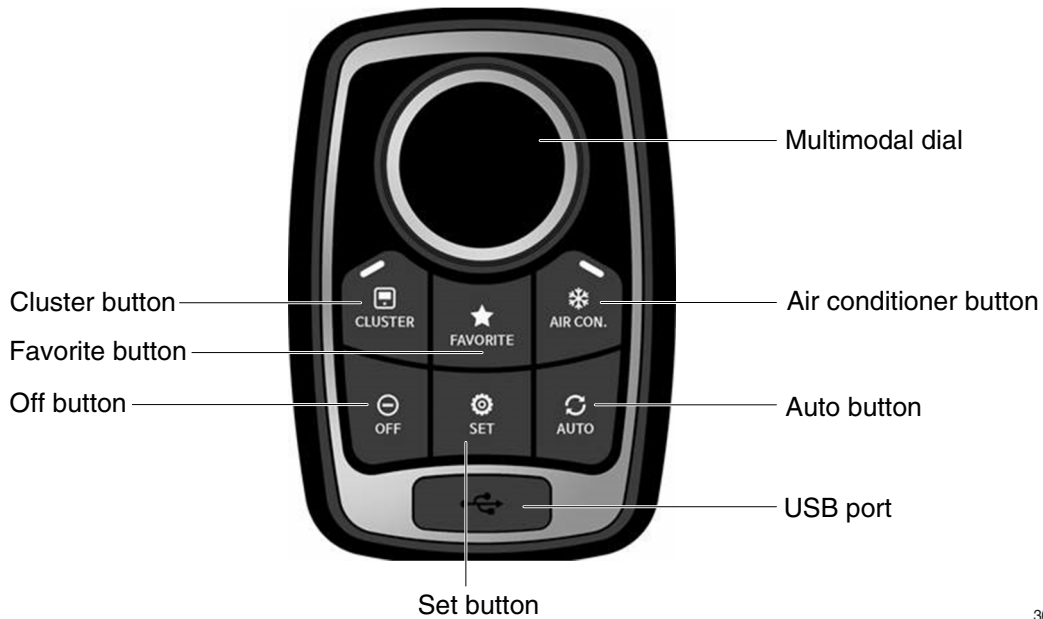

300A3CD150

(1) Multimodal dial

- Cluster interlocked mode OFF

① Acceleration mode

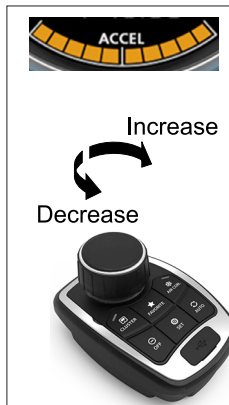

300A3CD151

- There are 10 dial settings.
- Setting 1 is low idle and setting 10 is high idle.
 - By rotating the dial to right : Engine speed increases
 - By rotating the dial to left : Engine speed decreases

(2) USB port



300A3CD152

- ① This port updates firmware using a dedicated cable.
- ② Jog dial module has a built-in charging circuit supply max 500 mA current.

(3) Cluster button



300A3CD153

- ① When you push this button, jog dial module will execute cluster interlocked mode.
- ② In cluster interlocked mode, if you push the cluster button, jog dial module returns to previous mode.
- ③ Cluster interlocked mode ON : Blue lamp comes ON
Cluster interlocked mode OFF : Blue lamp turns OFF

(4) Air conditioner button



300A3CD154

- ① When you push this button, air conditioner system is operated.
- ② Determines whether or not to perform a cooling function of air conditioner.
 - Blue lamp ON : Air conditioner operation
 - Amber lamp ON : Fan only

(5) Set button



300A3CD155

- ① When you push this button, jog dial module executes air conditioner mode and displays air conditioner control mode in cluster.
- ② Air conditioner control mode will disappear when you push SET button again within 10 seconds or when you do not touch anything for more than 10 seconds.

(6) OFF button



300A3CD156

- ① You can only use this button when the air conditioner system is operating.
- ② This button is only for air conditioner system off.

(7) Auto button



300A3CD157

- ① This button controls the auto function of air conditioner and heater system ON/OFF.
- ※ Refer to the page 3-37 for the auto switch of the air conditioner.

(8) Favorite button

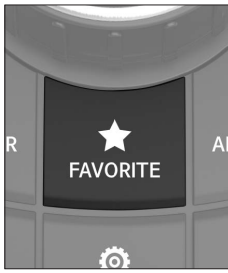

300A3CD158

- ① When you push this button for 2 seconds, cluster screen is saved.
- ② Push this button, cluster screen that you saved is opened.
- ※ **Saveable screen : Mode, Monitoring, Manage, Display, Utilities.**

(9) Cluster interlocked mode ON

① Cluster main menu

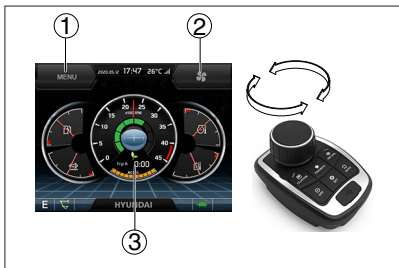

300A3CD160A

- You can select the quick menu by rotating the dial as below.

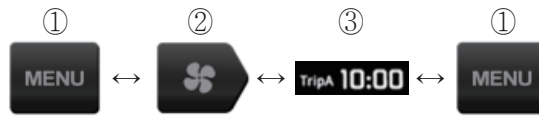

- CW rotation : move to right direction
- CCW rotation : move to left direction

② Cluster menu move



300A3CD161A

- You can move up and down the cluster sub menu.

③ Air conditioner menu



300A3CD162A

- You can move the menu of the air conditioner control mode.

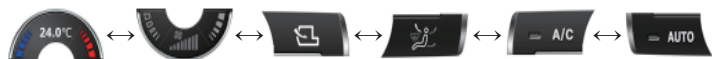

④ Slide choice menu

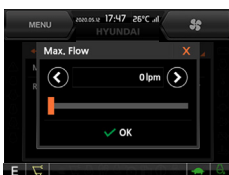

300A3CD163A

- You can increase or decrease the slide choice bar.

⑤ Level choice menu

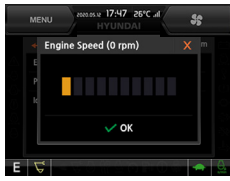

300A3CD164A

- You can increase or decrease the level choice bar.

⑥ Push button

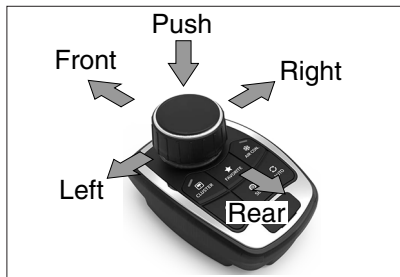

300A3CD165

- **Push** : Select the current menu or the pop-up warning lamp moves to the original position when warning lamp occurs.
- **Left** : ESC
- **Right** : CAM
- **Front** : Cluster main menu
- **Rear** : Return to acceleration mode

4) SEAT (SUSPENSION, STD)

The seat is adjustable to fit the contours of the operator's body. It will reduce operator fatigue due to long work hours and enhance work efficiency.

※ The seat belt reminder warning lamp pops up and the buzzer sounds until seat belt is fastened.

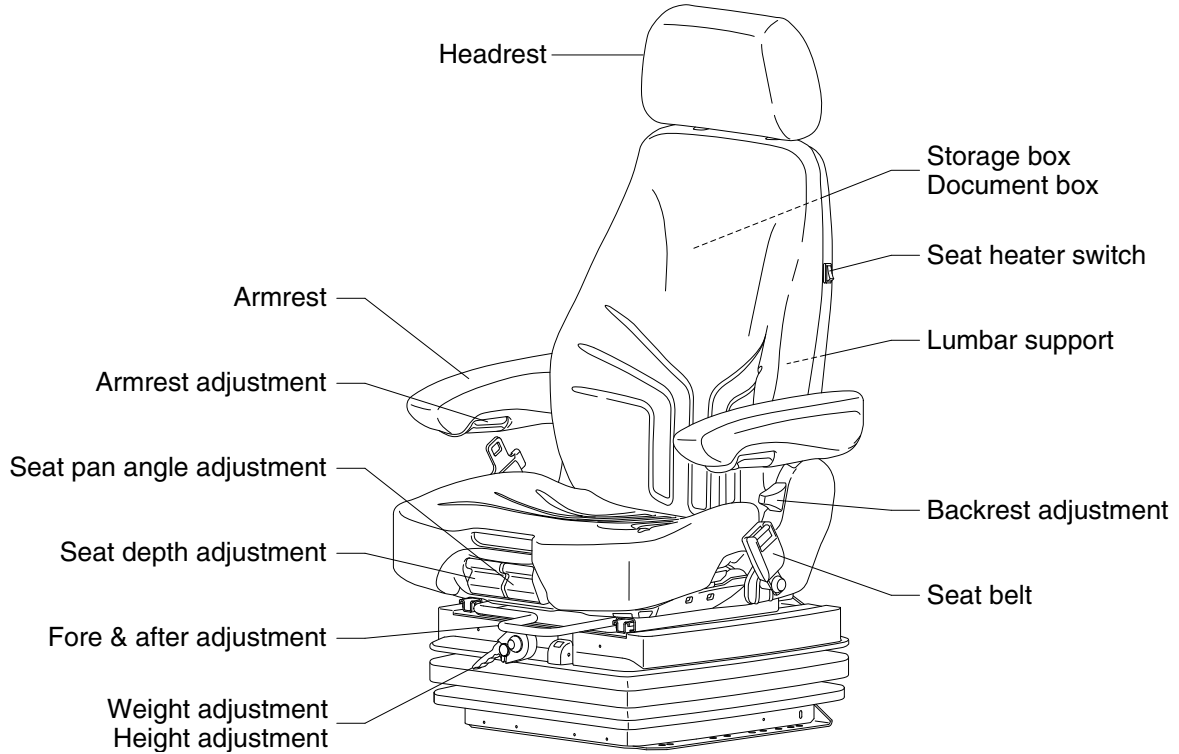

290F3CD270

(1) Weight and height adjustment

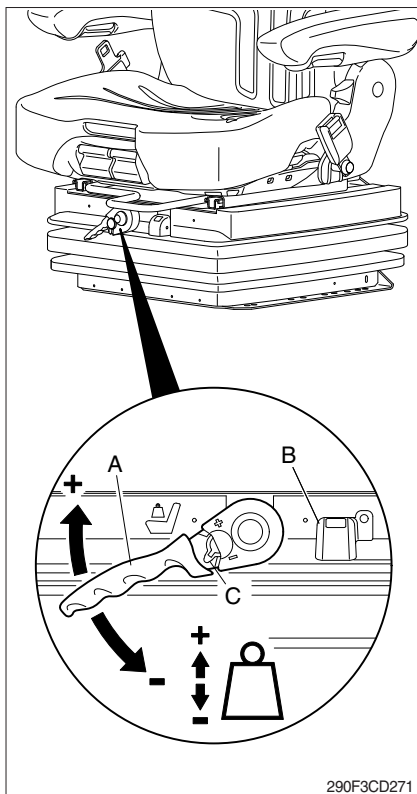

290F3CD271

With socket wrench (A) :

- ① The seat has to be adjusted for the operator's weight and height by tilting the handle (+) up or down (-) with the operator not sitting on the seat.
- ② The rotational direction is reversed by flipping the ratchet with the lever (C).
- ③ The operator's weight and the seat height are adjusted correctly when the green marking is completely visible in the indicator window (B) for weight and height.
- ④ The height can be adjusted individually as long as the green marking is visible.

(2) Fore/after adjustment

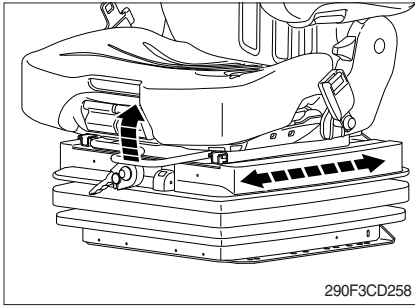

① The fore/after adjustment is released by lifting the locking lever.

▲ Do not operate the locking lever while operating the machine.

※ After the adjustment, the locking lever must latch into the desired position with an audible click. It should not be possible to move the operator's seat into another position when it is locked.

※ Do not lift the locking lever with your leg.

(3) Seat depth adjustment

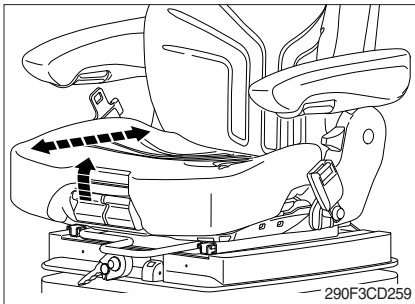

① The depth of the seat pan can be individually adjusted.

② To adjust the depth of the seat cushion, pull the right handle upwards. By moving the seat pan backwards or forwards the desired seating position can be reached.

(4) Seat pan angle adjustment

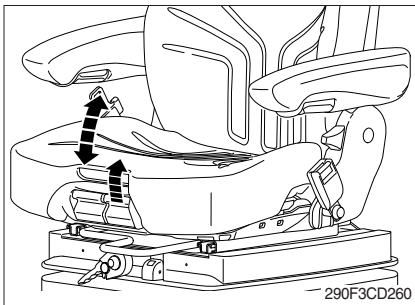

① The angle of the seat pan can be individually adjusted.

② To adjust the angle of the seat pan, pull the left handle upwards. By exerting pressure on or off the front or rear part of the seat pan it can be moved to the desired position.

(5) Armrests

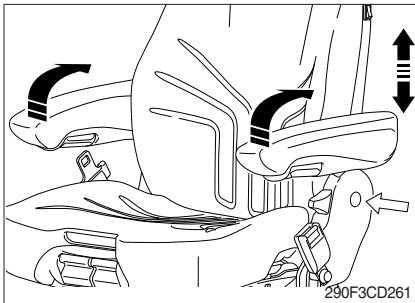

① The armrests can be folded up if desired and the height can be individually adjusted.

② To adjust the height of armrest, separate the round cap (see arrow) from the cover and loosen the hexagon nut (13 mm). Adjust the armrests to the desired position (5 steps) and retighten the nut. Reinstall the cap.

· Tightening torque : 2.6 kgf·m (18.8 kgf·m)

(6) Armrest adjustment

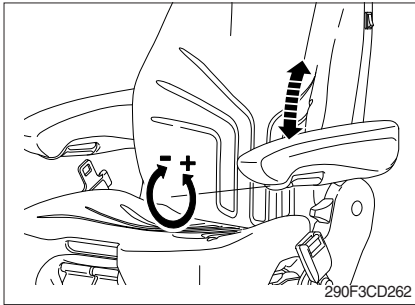

- ① The inclination of the armrest can be modified by turning the adjustment knob.
- ② When turning the knob to the outside (+), the front part of the armrest will be lifted; when turning the knob to the inside (-), it will be lowered.

(7) Headrest

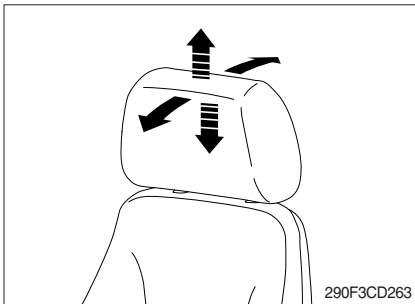

- ① The headrest can be individually adjusted for height by pulling it upward over the various increments up the end stop.
- ② By pushing forwards or rearwards the angle of the headrest can be adjusted individually.
- ③ To remove the headrest, pull it over the end stop.

(8) Document box

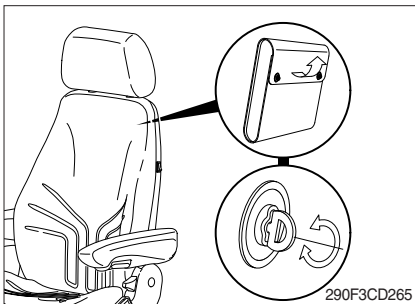

- ① The document box is placed on the rear side of the backrest.
- ② To open the document box, first twist the turn lock closures 90° to the left or the right and then fold the cover of the document box upwards.

(9) Seat heater switch

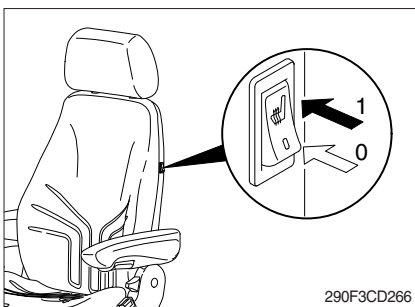

- ① The seat heater can be turned on/off by pressing the switch.

(10) Lumbar support

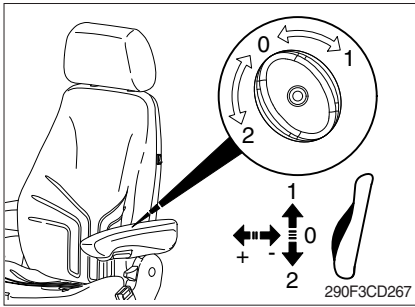

- ① By turning the adjustment knob to the left (2) or right (1), both the height and curvature of the backrest cushion can be individually adjusted.
- ② This increases both the seating comfort and should improve the performance of the operator.

(11) Backrest adjustment

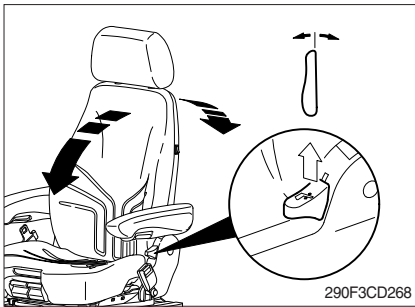

- ① Pull up the locking lever to release the backrest catch. When releasing the backrest, do not load the backrest by pressing against it.
 - ② By exerting pressure on or off the front or rear part of the seat pan it can be moved to the desired position. Release the locking lever to lock the backrest.
- ※ It should not be possible to move the backrest into another position after it has been locked.

(12) Maintenance



Dirt can impair the function of the seat, so make sure you keep your seat clean.

Upholstery does not need to be removed from the seat frame for cleaning.

▲ Take care with the backrest - it may jerk forward and cause injury.

When cleaning the backrest cushion, the backrest must be held in place when operating the backrest lever.

※ Do not clean the seat with a pressure washer.

During cleaning, the upholstery should never be soaked.

Use standard commercially available upholstery or plastics cleaning agent. Test first for compatibility on a small, concealed area.

5) SEAT (AIR SUSPENSION, OPTION)

The seat is adjustable to fit the contours of the operator's body. It will reduce operator fatigue in the event of long work hours and it should enhance work efficiency.

※ The seat belt reminder warning lamp pops up and the buzzer sounds until the seat belt is fastened.

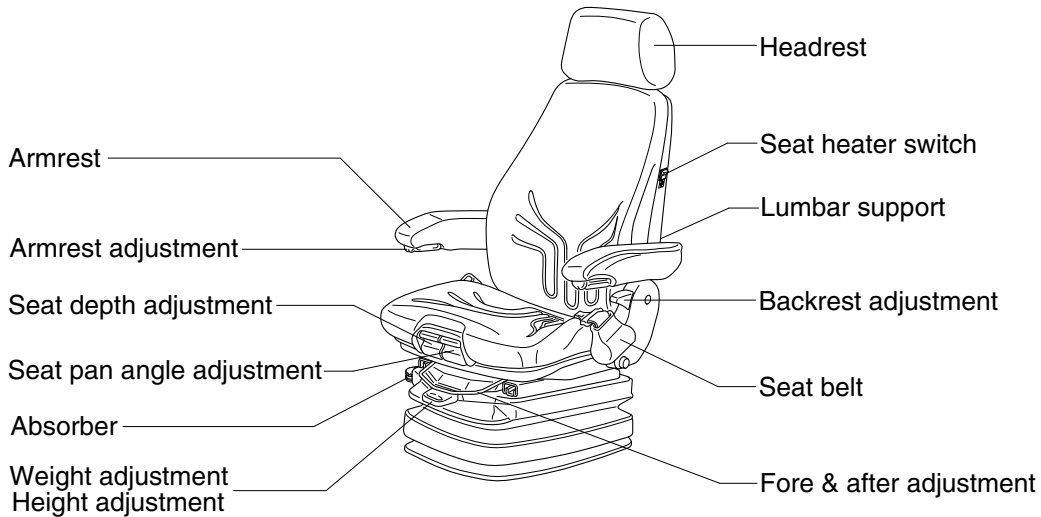

290F3CD28

(1) Weight adjustment

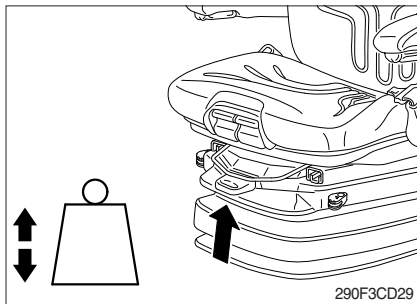

- ① The seat should be adjusted for the operator's weight by briefly pulling the actuator lever of the automatic weight and height adjuster (arrow) with the machine at a standstill and with the operator sitting on the seat.

The operator must sit absolutely still during adjustment.

- ※ **Before adjusting the weight, adjust shock absorbers to the position "soft".**
- ※ **To prevent personal health, the setting for the operator's weight must be checked and adjusted before the machine is operated.**

(2) Height adjustment

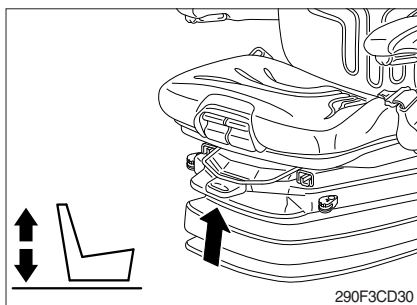

- ① The seat height can be set pneumatically and is continuously adjustable.
- ② The seat height can be altered by pulling or pressing the actuator lever fully out or in (arrow). If the adjustment reaches the top or bottom endstop, the height is adjusted automatically in order to provide minimum spring travel.

- ※ **Before adjusting the weight, adjust shock absorbers to the position "soft".**
- ※ **In order to avoid damage, do not operate compressor for more than 1 minute.**

(3) Seat pan angle adjustment

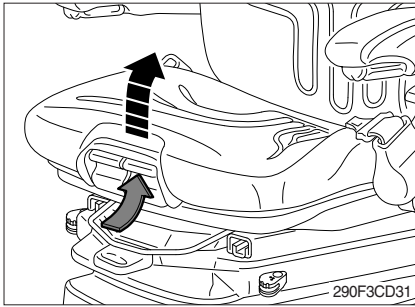

- ① The angle of the seat pan can be individually adjusted.
- ② To adjust the angle of the seat pan, lift the LH handle (see arrow). By exerting pressure on or off the seat pan it can be moved to the desired angled position.

(4) Seat depth adjustment

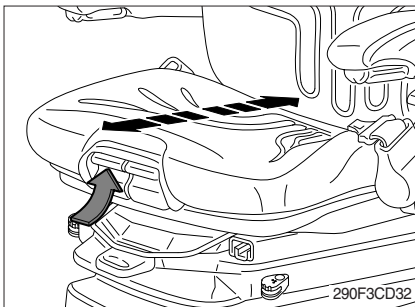

- ① The depth of the seat pan can be individually adjusted.
- ② To adjust the depth of the seat cushion, lift the RH handle (see arrow). Move the seat cushion backwards or forwards until the desired position is reached.

(5) Absorber

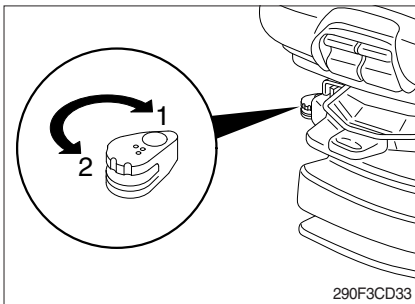

- ① The absorber setting of the seat can be varied to suit on and off-road working conditions. The cushioning effect can be individually adjusted for this purpose.

Turn the lever to the desired position and release.

- 1 Soft
- 2 Hard

(6) Armrest adjustment

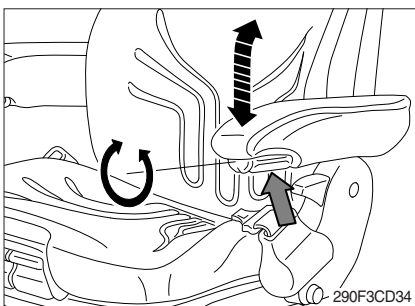

- ① The inclination of the armrests can be modified by turning the adjustment knob (arrow).

(7) Armrests

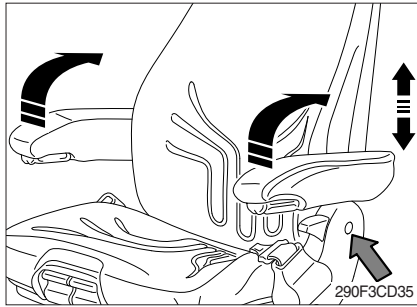

- ① The armrests can be folded up if desired and the height can be individually adjusted.
- ② To adjust the height of armrest, separate the round cap (see arrow) from the cover and loosen the hexagon nut (13 mm). Adjust the armrests to the desired position (5 steps) and retighten the nut. Reinstall the cap.
 - Tightening torque : 2.6 kgf·m (18.8 kgf·m)

(8) Headrest

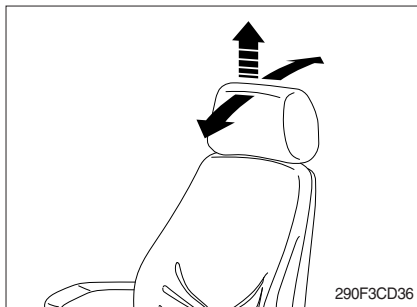

- ① The headrest can be individually adjusted for height by pulling it upward over the various increments up the end stops.
- ② By pushing forward or rearward the angle of the headrest can be adjusted individually.
- ③ To remove the headrest, pull it over the end stops.

(9) Seat heater switch

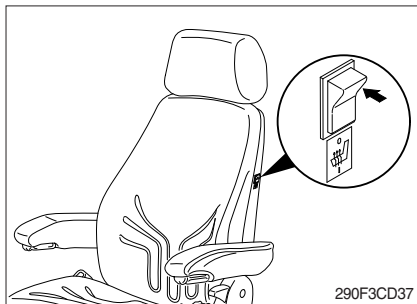

- ① The seat heater is turned on by pressing the switch.

(10) Lumbar support

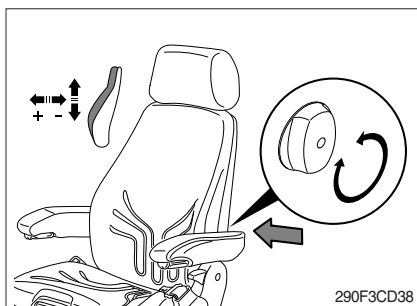

- ① By turning the adjustment knob to the left or right, both the height and curvature of the backrest cushion can be individually adjusted.
- ② This increases both the seating comfort and should help improve performance of operator.

(11) Backrest adjustment

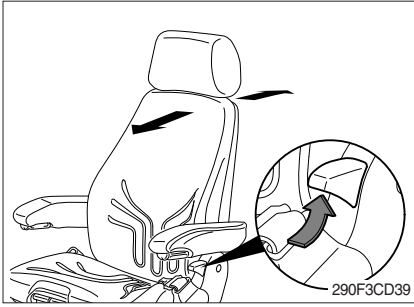

- ① The backrest is adjusted using the locking lever (arrow).
- ※ The locking lever must latch into the desired position. It should not be possible to move the backrest when it is locked.

(12) Fore & after adjustment

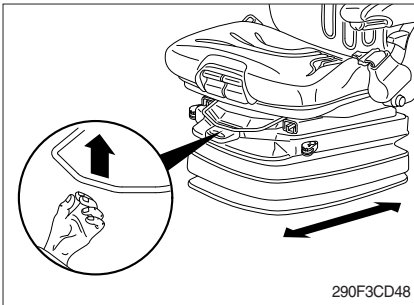

- ① The fore/after adjustment is released by lifting the locking lever.
- ※ The locking lever must latch into the desired position. It should not be possible to move the operator when it is locked.

(13) Seat belt

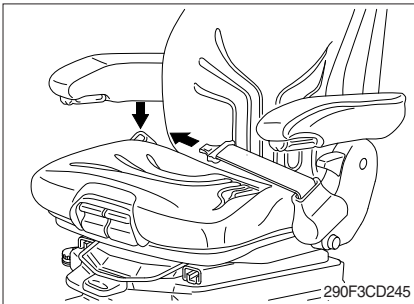

- ▲ Failure to wear a seat belt during machine operation may result in serious injury or death in the event of an accident or machine overturn.

6) FUSE & RELAY BOX

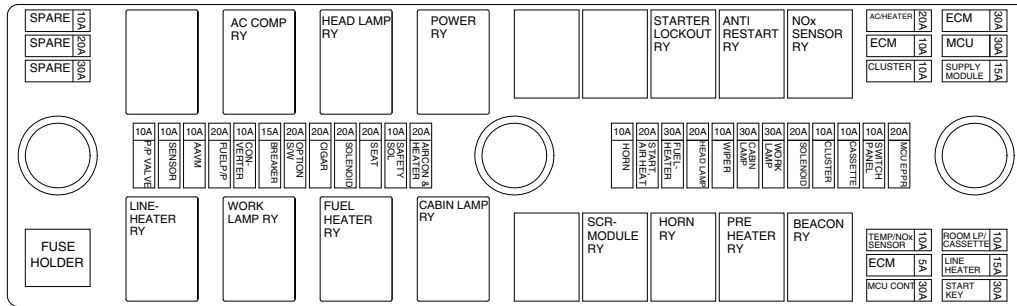

290F3CD290

- (1) The fuses protect the electrical parts and wiring from burning out.
 - (2) The fuse box cover indicates the capacity of each fuse and which circuit it protects.
- ※ **When replacing a fuse or relay, always use one of the same capacity.**
- ▲ **Before replacing a fuse or relay, be sure to turn OFF the starting switch.**

7) MCU

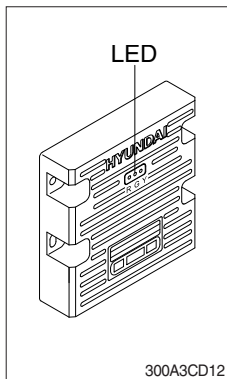

- (1) To match the pump absorption torque with the engine torque, MCU varies EPPR valve output pressure, which controls pump discharge volume whenever engine speed drops and provides feedback, under the reference rpm of each mode set.
- (2) Three LED lamps on the MCU display as below.

LED lamp	Trouble	Service
G is turned ON	Normal	-
G and R are turned ON	Trouble on MCU	· Change the MCU
G and Y are turned ON	Trouble on serial communication line	· Check if serial communication lines between controller and cluster are disconnected
Three LED's are turned OFF	Trouble on MCU power	· Check if the input power wire (24 V, GND) of controller is disconnected · Check the fuse

G : green, R : red, Y : yellow

8) EMERGENCY ENGINE SPEED CONTROL CONNECTOR

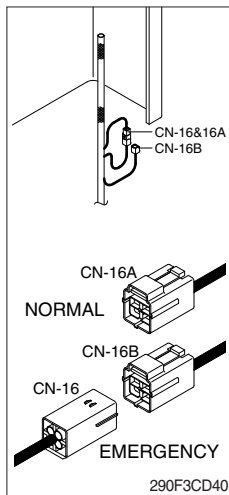

(1) When the CAN communication between the ECM and the MCU is abnormal due to malfunction, change the CN-16 connection from CN-16A to CN-16B and then control the engine speed by rotating the multimodal module of the jog dial module.

※ **Never connect connector CN-16 with CN-16B when MCU is in normal operation.**

※ **Make repair as soon as possible.**

9) SERVICE METER

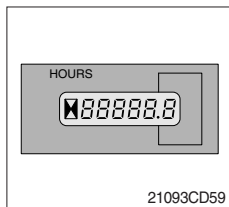

(1) This meter shows the total operation hours of the machine.

(2) Always ensure the operating condition of the meter during the machine operation. Inspect and service the machine based on hours as indicated in chapter 6, maintenance.

10) MCU/ECM CONNECTOR

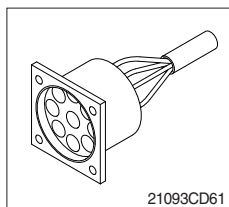

(1) MCU communicates the machine data with Laptop computer through the connector.

(2) ECM communicates the engine data with cummins INSITE adapter through the connector.

① ECM fault code check

② ECM program change

③ Engine data monitoring & test

11) 12V SOCKET

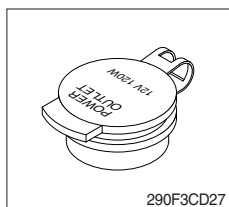

(1) Utilize the power of 12 V as you need and do not exceed 12 V, 30 W.

12) UPPER WINDSHIELD

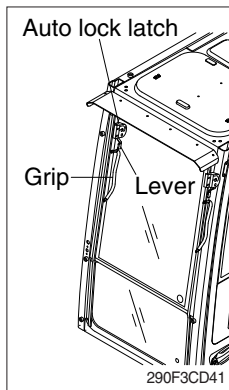

(1) Perform the following procedure in order to open the upper windshield.

- ① Pull both levers with hold both grips that are located at the top of the windshield frame and push the windshield upward.
- ② Hold both grips and pull back into the lock position until auto lock latch is engaged, then release the grips.

▲ When working, without having locked the windshield by the auto lock (by pushing the windshield to the rear until it's completely fixed), please be careful as it can cause personal injury if the windshield is not fixed or falls off.

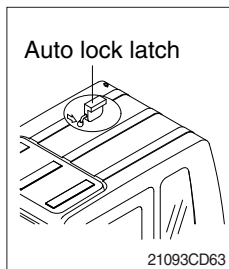

(2) Perform the following procedure in order to close the upper windshield.

- ① Pull the lever of the auto lock latch in order to release the auto lock latch.
- ② Steps in the reverse order to close the upper windshield.

1. INSTRUCTION

1) INTERVAL OF MAINTENANCE

- (1) Inspect and service machine as described on page 4-11.
- (2) Shorten intervals of inspection and service depending on site conditions. (such as dusty area, quarry, sea shore and etc.)
- (3) Practice the entire related details at the same time when the service interval is doubled.
For example, in case of 100 hours, carry out all the maintenance 「Each 100 hours, each 50 hours and daily service」 at the same time.

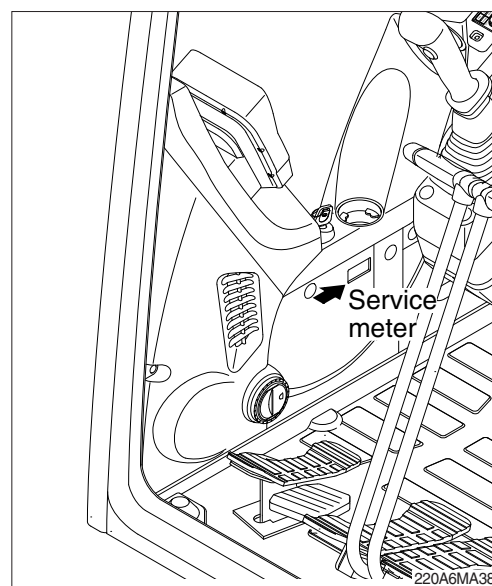

2) PRECAUTION

- (1) Do not perform maintenance on the machine until you have read the operator's manual and are familiar with the machine.
- (2) Daily inspection should be performed according to section, Maintenance check list.
- (3) Engine and hydraulic components have been preset from the factory.
Do not allow unauthorized personnel to reset them.
- (4) Drain the used oil and coolant (always in separate containers). Handle and dispose of the waste per regulation of each province/country as well as any local laws.
- ▲ **Hot oil and hot components can cause serious injury or death. Do not allow hot oil or hot components to contact skin. Failure to comply may result in serious injury or death.**
- △ **Accumulated grease and oil on the machine is a fire hazard. Remove any coating/film of fuel, oil or grease by steam cleaning the machine with high pressure water. Perform this at minimum of 1000 hours.**
- △ **Inspect the engine compartment for any trash build up. Remove any trash build up from the engine compartment.**
- (5) Ask your local dealer or Hyundai for the maintenance advice if unknown.

3) PROPER MAINTENANCE

(1) Replace and repair of parts

It is required to replace the wearable and consumable parts such as bucket tooth, side cutter, filter and etc., regularly. Replace damaged or worn parts before or at the required time to maintain machine performance.

- (2) Always use only Hyundai genuine parts.
 - (3) Use the recommended oil.
 - (4) Do not perform repairs while the machine is running. Stop the engine when you fill the oil.
 - (5) Always wear protective goggles, protective gloves and other personal protective equipment.
 - (6) Clean around the inlet of oil tank before adding oil.
 - (7) Drain oil when the temperature of oil is warm.
 - (8) Relieve hydraulic system of pressure before repairing the hydraulic system.
 - (9) Confirm if cluster has any warnings present after completion of service.
 - (10) For more detail information of maintenance, please contact your local Hyundai dealer.
- ※ **Read chapter 1 of this manual for safety instructions prior to performing any maintenance on the machine.**

4) RELIEVING THE PRESSURE IN THE HYDRAULIC SYSTEM

※ Spewing of oil can cause an severe personal injury. Before you loosen hydraulic cap or any hydraulic line on the machine, always make sure machine of off, cooled down and that pressure is relived of the hydraulic system.

- (1) Place the machine in the position shown and stop engine.

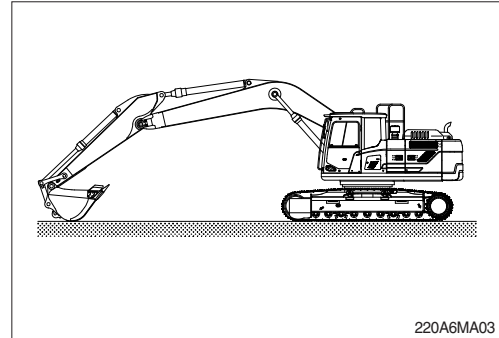

- (2) Set the safety knob completely in the UNLOCK position. Refer to section Levers and pedals. Operate the control levers and pedals fully to the front, rear, left and right, to release the pressure in the hydraulic circuit.

※ This does not completely release the pressure, so when servicing hydraulic component, loosen the connections slowly and do not stand in the direction where the oil may shoot out.

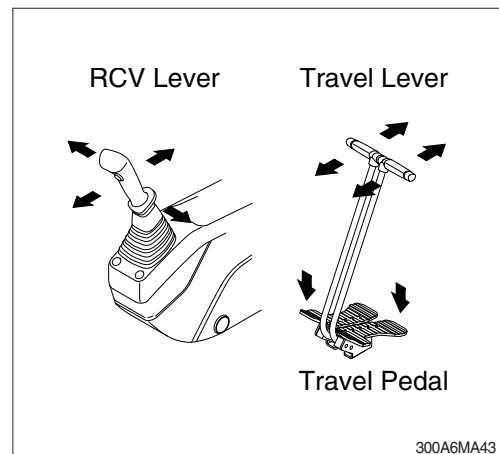

- (3) Relieve the pressure in the tank by pushing the top of the air breather.

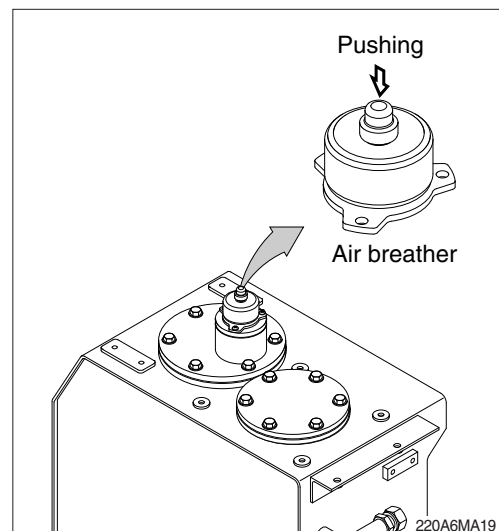

5) PRECAUTION WHEN INSTALLING HYDRAULIC HOSES OR PIPES

- (1) Be particularly careful that the joint of hose, pipe and functioning item are not damaged.
Avoid contamination.
- (2) Assemble after cleaning the hose, pipe and joint of functioning item.
- (3) Use genuine parts.
- (4) Do not install hose in a twisted, bent or crimped way.
- (5) Always maintain the specified torque.

6) PERIODIC REPLACEMENT OF PARTS

- (1) Perform periodic maintenance of the machine to prolong its useful life. This will assure and allow you to use the machine safely for a long time.
It is recommended to replace any parts related to safety (as needed), not only for safety but in order to maintain performance as well.
- (2) These parts can shorten the life of the machine. The life span of such parts cannot be viewed visually and judged by the operator.
- (3) Repair or replace if any abnormality of these parts is found even before the recommended replacement interval.

Periodic replacement of parts			Interval
Engine		Fuel hose (tank-engine)	Every 2 years
		Heater hose (heater-engine)	
Hydraulic system	Main circuit	Pump suction hose	Every 2 years
		Pump delivery hose	
		Swing hose	
	Working device	Boom cylinder line hose	Every 2 years
		Arm cylinder line hose	
		Bucket cylinder line hose	

※ **Replace O-ring and gasket at the same time when replacing the hose.**

Replace clamp at the same time if the hose clamp is cracked when checking and replacing the hose.

2. TIGHTENING TORQUE

Use following table for unspecified torque.

1) BOLT AND NUT

(1) Coarse thread

Bolt size	8.8T		10.9T		12.9T	
	kgf · m	lbf · ft	kgf · m	lbf · ft	kgf · m	lbf · ft
M 6×1.0	0.8 ~ 1.2	5.8 ~ 8.6	1.2 ~ 1.8	8.7 ~ 13.0	1.5 ~ 2.1	10.9 ~ 15.1
M 8×1.25	2.0 ~ 3.0	14.5 ~ 21.6	2.8 ~ 4.2	20.3 ~ 30.4	3.4 ~ 5.0	24.6 ~ 36.1
M10×1.5	4.0 ~ 6.0	29.0 ~ 43.3	5.6 ~ 8.4	40.5 ~ 60.8	6.8 ~ 10.0	49.2 ~ 72.3
M12×1.75	6.8 ~ 10.2	50.0 ~ 73.7	9.6 ~ 14.4	69.5 ~ 104	12.3 ~ 16.5	89.0 ~ 119
M14×2.0	10.9 ~ 16.3	78.9 ~ 117	16.3 ~ 21.9	118 ~ 158	19.5 ~ 26.3	141 ~ 190
M16×2.0	17.9 ~ 24.1	130 ~ 174	25.1 ~ 33.9	182 ~ 245	30.2 ~ 40.8	141 ~ 295
M18×2.5	24.8 ~ 33.4	180 ~ 241	34.8 ~ 47.0	252 ~ 340	41.8 ~ 56.4	302 ~ 407
M20×2.5	34.9 ~ 47.1	253 ~ 340	49.1 ~ 66.3	355 ~ 479	58.9 ~ 79.5	426 ~ 575
M22×2.5	46.8 ~ 63.2	339 ~ 457	65.8 ~ 88.8	476 ~ 642	78.9 ~ 106	570 ~ 766
M24×3.0	60.2 ~ 81.4	436 ~ 588	84.6 ~ 114	612 ~ 824	102 ~ 137	738 ~ 991
M30×3.5	120 ~ 161	868 ~ 1164	168 ~ 227	1216 ~ 1641	202 ~ 272	1461 ~ 1967

(2) Fine thread

Bolt size	8.8T		10.9T		12.9T	
	kgf · m	lbf · ft	kgf · m	lbf · ft	kgf · m	lbf · ft
M 8×1.0	2.1 ~ 3.1	15.2 ~ 22.4	3.0 ~ 4.4	21.7 ~ 31.8	3.6 ~ 5.4	26.1 ~ 39.0
M10×1.25	4.2 ~ 6.2	30.4 ~ 44.9	5.9 ~ 8.7	42.7 ~ 62.9	7.0 ~ 10.4	50.1 ~ 75.2
M12×1.25	7.3 ~ 10.9	52.8 ~ 78.8	10.3 ~ 15.3	74.5 ~ 110	13.1 ~ 17.7	94.8 ~ 128
M14×1.5	12.4 ~ 16.6	89.7 ~ 120	17.4 ~ 23.4	126 ~ 169	20.8 ~ 28.0	151 ~ 202
M16×1.5	18.7 ~ 25.3	136 ~ 182	26.3 ~ 35.5	191 ~ 256	31.6 ~ 42.6	229 ~ 308
M18×1.5	27.1 ~ 36.5	196 ~ 264	38.0 ~ 51.4	275 ~ 371	45.7 ~ 61.7	331 ~ 446
M20×1.5	37.7 ~ 50.9	273 ~ 368	53.1 ~ 71.7	384 ~ 518	63.6 ~ 86.0	460 ~ 622
M22×1.5	51.2 ~ 69.2	370 ~ 500	72.0 ~ 97.2	521 ~ 703	86.4 ~ 116	625 ~ 839
M24×2.0	64.1 ~ 86.5	464 ~ 625	90.1 ~ 121	652 ~ 875	108 ~ 146	782 ~ 1056
M30×2.0	129 ~ 174	933 ~ 1258	181 ~ 245	1310 ~ 1772	217 ~ 294	1570 ~ 2126

2) PIPE AND HOSE (FLARE type)

Thread size (PF)	Width across flat (mm)	kgf · m	lbf · ft
1/4"	19	4	28.9
3/8"	22	5	36.2
1/2"	27	9.5	68.7
3/4"	36	18	130
1"	41	21	152
1-1/4"	50	35	253

3) PIPE AND HOSE (ORFS type)

Thread size (UNF)	Width across flat (mm)	kgf · m	lbf · ft
9/16-18	19	4	28.9
11/16-16	22	5	36.2
13/16-16	27	9.5	68.7
1-3/16-12	36	18	130
1-7/16-12	41	21	152
1-11/16-12	50	35	253

4) FITTING

Thread size	Width across flat (mm)	kgf · m	lbf · ft
1/4"	19	4	28.9
3/8"	22	5	36.2
1/2"	27	9.5	68.7
3/4"	36	18	130
1"	41	21	152
1-1/4"	50	35	253

5) TIGHTENING TORQUE OF MAJOR COMPONENT

No.	Descriptions	Bolt size	Torque		
			kgf · m	lbf · ft	
1	Engine	Engine mounting bolt (engine-bracket)	M12 × 1.75	11.5 ± 1.0	83.2 ± 7.2
2		Engine mounting bolt (bracket-frame, FR)	M20 × 2.5	52.1 ± 5.0	377 ± 36.2
3		Engine mounting bolt (bracket-frame, RR)	M24 × 3.0	90 ± 9.0	651 ± 65.1
4		Radiator mounting bolt	M16 × 2.0	29.7 ± 4.5	215 ± 32.5
5		Coupling mounting socket bolt	M18 × 2.5	32 ± 1.0	231 ± 7.2
6		Fuel tank mounting bolt	M20 × 2.5	46 ± 5.1	333 ± 36.9
7	Hydraulic system	Main pump housing mounting bolt	M10 × 1.5	6.5 ± 0.7	47 ± 5.1
8		Main pump mounting socket bolt	M20 × 2.5	42 ± 4.5	304 ± 32.5
9		Main control valve mounting nut	M12 × 1.75	12.3 ± 1.3	89.0 ± 9.4
10		Hydraulic oil tank mounting bolt	M20 × 2.5	46 ± 5.1	333 ± 36.9
11		Turning joint mounting bolt, nut	M12 × 1.75	12.3 ± 1.3	89.0 ± 9.4
12	Power train system	Swing motor mounting bolt	M20 × 2.5	57.9 ± 5.8	419 ± 42
13		Swing bearing upper part mounting bolt	M20 × 2.5	57.9 ± 5.8	419 ± 42
14		Swing bearing upper part mounting bolt (HW)	M24 × 3.0	100 ± 15	723 ± 109
15		Swing bearing lower part mounting bolt	M20 × 2.5	57.9 ± 5.8	419 ± 42
16		Swing bearing lower part mounting bolt (HW)	M24 × 3.0	100 ± 15	723 ± 109
17		Travel motor mounting bolt	M16 × 2.0	23 ± 2.5	166 ± 18.1
18		Sprocket mounting bolt	M16 × 2.0	29.7 ± 3.0	215 ± 21.7
19	Under carriage	Carrier roller mounting bolt, nut	M16 × 2.0	29.7 ± 3.0	215 ± 21.7
20		Track roller mounting bolt	M20 × 2.5	57.9 ± 6.0	419 ± 43.4
21		Track tension cylinder mounting bolt	M16 × 2.0	29.7 ± 4.5	215 ± 32.5
22		Track shoe mounting bolt, nut	M20 × 1.5	78 ± 8.0	564 ± 57.9
23		Track guard mounting bolt (general)	M20 × 2.5	57.9 ± 8.7	419 ± 62.9
24		Track guard mounting bolt (full track)	M24 × 3.0	100 ± 15	723 ± 109
25	Others	Counterweight mounting bolt	M36 × 3.0	337 ± 33	2440 ± 239
26		Cab mounting bolt	M12 × 1.75	12.8 ± 3.0	92.6 ± 21.7
27		Operator's seat mounting bolt	M 8 × 1.25	4.05 ± 0.8	29.3 ± 5.8
28		Under cover mounting bolt	M12 × 1.75	12.8 ± 3.0	92.6 ± 21.7

※ For tightening torque of engine and hydraulic components, see engine maintenance guide and service manual.

3. FUEL, COOLANT AND LUBRICANTS

1) NEW MACHINE

New machine used and filled with following lubricants.

Description	Specification
Engine oil (API CK-4)	SAE 15W-40, ★SAE 5W-40
DEF/AdBlue®	ISO 22241 (32.5% high-purity urea and 67.5% deionized water)
Hydraulic oil	Hyundai genuine long life hydraulic oil (ISO VG 32, VG 46, VG 68) Conventional hydraulic oil (ISO VG 15★) Hyundai Bio Hydraulic Oil (HBHO, ISO VG 46)
Swing and travel reduction gear	SAE 80W-90 (GL-4/GL-5)
Grease	Lithium base grease NLGI No. 2
Fuel	ASTM D975-No. 2, Ultra low sulfur diesel
Coolant (DCA4)	ASTM D6210 Mixture of 50% ethylene glycol base antifreeze and 50% water. Mixture of 60% ethylene glycol base antifreeze and 40% water.★

SAE : Society of Automotive Engineers

API : American Petroleum Institute

ISO : International Organization for Standardization

NLGI : National Lubricating Grease Institute

ASTM : American Society of Testing and Material

DEF : Diesel Exhaust Fluid

DEF compatible with AdBlue®

DCA4 : Brand name of Chemical Additive

manufactured by the Cummins Fleetguard Co.

Ultra low sulfur diesel

- sulfur content ≤ 15 ppm

★Cold region

Russia, CIS, Mongolia

※ Refer to the page 7-29 for further information of recommended oils.

2) RECOMMENDED OILS

HYUNDAI genuine lubricating oils have been developed to offer the best performance and service life for your equipment. These oils have been tested according to the specifications of HYUNDAI and, therefore, will meet the highest safety and quality requirements.

We recommend that you use only HYUNDAI genuine lubricating oils and grease officially approved by HYUNDAI.

Service point	Kind of fluid	Capacity ℓ (U.S. gal)	Ambient temperature °C (°F)										
			-50 (-58)	-30 (-22)	-20 (-4)	-10 (14)	0 (32)	10 (50)	20 (68)	30 (86)	40 (104)		
Engine oil pan	Engine oil	23.1 (6.1)	★SAE 0W-40										
			SAE 5W-40										
			SAE 15W-40										
DEF/AdBlue® tank	Mixture of urea and deionized water	48 (12.6)	ISO 22241, High-purity urea + deionized water (32.5:67.5)										
Swing drive	Gear oil	6.2 (1.6)	★SAE 75W-90										
Final drive		4.5×2 (1.2×2)	SAE 80W-90										
Hydraulic tank	Hydraulic oil	Tank 160 (42.3)	★ISO VG 15										
			ISO VG 32										
		System 275 (72.6)	ISO VG 46, HBHO VG 46★ ³										
			ISO VG 68										
Fuel tank	Diesel fuel★ ¹	400 (106)	★ASTM D975 NO.1										
			ASTM D975 NO.2										
Fitting (grease nipple)	Grease	As required	★NLGI NO.1										
			NLGI NO.2										
Radiator (reservoir tank)	Mixture of antifreeze and soft water★ ²	40 (10.6)	Ethylene glycol base permanent type (50 : 50)										
			★Ethylene glycol base permanent type (60 : 40)										

SAE : Society of Automotive Engineers

API : American Petroleum Institute

ISO : International Organization for Standardization

NLGI : National Lubricating Grease Institute

ASTM : American Society of Testing and Material

DEF : Diesel Exhaust Fluid, DEF compatible with AdBlue®

★ : Cold region (Russia, CIS, Mongolia)

★¹ : Ultra low sulfur diesel
- sulfur content ≤ 15 ppm

★² : Soft water
City water or distilled water

★³ : Hyundai Bio Hydraulic Oil

※ Using any lubricating oils other than HYUNDAI genuine products may lead to a deterioration of performance and cause damage to major components.

※ Do not mix HYUNDAI genuine oil with any other lubricating oil as it may result in damage to the systems of major components.

※ Do not use any engine oil other than that specified above, as it may clog the diesel particulate filter(DPF).

※ For HYUNDAI genuine lubricating oils and grease for use in regions with extremely low temperatures, please contact your local Hyundai dealer.

4. MAINTENANCE CHECK LIST

1) DAILY SERVICE BEFORE STARTING

Check items	Service	Page
Visual check		
· Charge air piping	Check	4-30
· Cooling fan	Check	4-26
· After treatment exhaust piping	Check	-
· Air intake piping	Check	-
· Air cleaner dust ejection valve	Check	-
· Crankcase breather tube	Check	-
Fuel tank	Check, Refill	4-28
Hydraulic oil level	Check, Add	4-40
Engine oil level	Check, Add	4-20
Radiator coolant level	Check, Add	4-22
Control panel & pilot lamp	Check, Clean	4-51
Fuel pre-filter	Check, Drain	4-29
Fan belt tension and damage	Check, Adjust	4-26, 27
★ Attachment pin and bushing	Lubricate	4-50
· Boom cylinder tube end		
· Boom foot		
· Boom cylinder rod end		
· Arm cylinder tube end		
· Arm cylinder rod end		
· Boom + Arm connecting		
· Bucket cylinder tube end		

★ Lubricate every 10 hours or daily for initial 100 hours.

2) EVERY 50 HOURS SERVICE

Check items	Service	Page
Fuel tank (water, sediment)	Drain	4-28
Track tension	Check, Adjust	4-46
Swing reduction gear oil	Check, Add	4-43
Attachment pin and bushing	Lubricate	4-50
· Bucket cylinder rod end		
· Bucket + Arm connecting		
· Bucket control link + Arm		
· Bucket control rod		

3) INITIAL 50 HOURS SERVICE

Check items	Service	Page
Bolts & Nuts · Sprocket mounting bolts · Upper roller mounting bolt · Lower roller mounting bolt · Travel motor mounting bolts · Swing motor mounting bolts · Swing bearing mounting bolts · Engine mounting bolts · Counterweight mounting bolts · Turning joint locating bolts · Track shoe mounting bolts and nuts · Track guard mounting bolts · Hydraulic pump mounting bolts · Under cover mounting bolts	Check, Tight	4-8

4) EVERY 200 HOURS SERVICE

Check items	Service	Page
★ Hydraulic oil return filter	Replace	4-42
★ Pilot line filter element	Replace	4-43
★ Drain filter	Replace	4-42

★ **Replace 3 filters for continuous hydraulic breaker operation only.**

5) INITIAL 250 HOURS SERVICE

Check items	Service	Page
Engine oil	Change	4-20, 21
Engine oil filter	Replace	4-20, 21
Fuel pre-filter element	Replace	4-29
Fuel filter element	Replace	4-30
Pilot line filter element	Replace	4-43
Hydraulic oil return filter	Replace	4-42
Drain filter	Replace	4-42
Swing reduction gear oil	Change	4-43
Travel reduction gear oil	Change	4-45

6) EVERY 250 HOURS SERVICE

Check items	Service	Page
Charge air piping	Check	4-30
Charge air cooler	Check	4-25
Battery (voltage), battery cable and connections	Check, Clean	4-51,53
Swing bearing grease	Lubricate	4-43
Bolts & Nuts	Check, Tight	4-8
· Sprocket mounting bolts		
· Upper roller mounting bolt		
· Lower roller mounting bolt		
· Travel motor mounting bolts		
· Swing motor mounting bolts		
· Swing bearing mounting bolts		
· Engine mounting bolts		
· Counterweight mounting bolts		
· Turning joint locating bolts		
· Track shoe mounting bolts and nuts		
· Track guard mounting bolts		
· Hydraulic pump mounting bolts		
· Under cover mounting bolts		
Attachment pin and bushing	Lubricate	4-50
· Boom cylinder tube end		
· Boom foot		
· Boom cylinder rod end		
· Arm cylinder tube end		
· Arm cylinder rod end		
· Boom + Arm connecting		
· Bucket cylinder tube end		

7) EVERY 500 HOURS SERVICE

Check items	Service	Page
Radiator, cooler fin and charge air cooler	Check, Clean	4-25
Aircon and heater outer filter	Replace	4-54
Aircon and heater inner filter	Replace	4-54
Air cleaner element (primary)★1	Check, Clean	4-28

★1 When working in dusty environments, more frequent cleaning is highly recommended.

8) EVERY 800 HOURS SERVICE

Check items	Service	Page
Engine oil★	Change	4-20, 21
Engine oil filter★	Replace	4-20, 21

★ Change oil and filter every 500 hours when using API CJ-4

9) EVERY 1000 HOURS SERVICE

Check items	Service	Page
Fuel filter element	Replace	4-30
Fuel pre-filter element	Replace	4-29
Drive belt, cooling fan	Check	4-26
Cooling fan belt tensioner	Check	4-27
Travel reduction gear oil	Change	4-45
Swing reduction gear oil	Change	4-43
Swing gear and pinion grease	Change	4-44
Hydraulic oil return filter	Replace	4-42
Drain filter	Replace	4-42
Pilot line filter element	Replace	4-43
Hydraulic tank air breather element	Replace	4-42

10) EVERY 2000 HOURS SERVICE

Check items	Service	Page
Engine cleaning	Clean	4-34
Vibration damper (rubber)	Check	4-35
Vibration damper (viscous)	Check	4-35
Coolant, cooling system and antifreeze	Change, Flush	4-22, 23, 24, 25
Hydraulic oil* ²	Change	4-41
HBHO (Hyundai Bio Hydarulic Oil, ISO VG 46)* ³	Change	4-41
Hydraulic oil suction strainer	Check, Clean	4-41
Air cleaner element (primary, safety)* ⁴	Replace	4-28
DEF/AdBlue® tank filter	Replace	4-32
RCV lever	Check, Lubricate	4-45
Hoses, fittings, clamps (fuel, coolant, hydraulic)	Check, Retighten, Replace	-

*² Conventional hydraulic oil

*³ If you do not want to change HBHO every 2000 hours, contact your local Hyundai dealer and ask about SAMPLING.

*^{2,*3} Change oil every 600 hours of continuous hydraulic breaker operation.

*⁴ When working in dusty environments, more frequent replacing is highly recommended.

11) EVERY 4500 HOURS SERVICE

Check items	Service	Page
DEF/AdBlue® supply module filter★	Replace	4-33

★ When working in dusty environments, inspection per 1500 hours is highly recommended.

12) EVERY 5000 HOURS SERVICE

Check items	Service	Page
Overhead set (shop inspection)	Adjust	4-36, 37, 38
Hydraulic oil* ⁵	Change	4-41

*⁵ Hyundai genuine long life hydraulic oil

*⁵ Change oil every 1000 hours of continuous hydraulic breaker operation.

13) WHEN REQUIRED

Whenever you have trouble with the machine, you must perform the service of related items, system by system.

Check items	Service	Page
Fuel system		
· Fuel tank	Drain or Clean	4-28
· Fuel pre-filter	Drain, Replace	4-29
· Fuel filter element	Replace	4-30
· Fuel filler pump filter	Clean, Replace	4-39
Engine lubrication system		
· Engine oil	Change	4-20, 21
· Engine oil filter	Replace	4-20, 21
Engine cooling system		
· Radiator coolant	Add or Change	4-22, 23, 24, 25
· Radiator	Clean or Flush	4-22, 23, 24, 25
· Charge air cooler	Check, Clean	4-25
Engine air system		
· Air cleaner element (primary)	Clean or Replace	4-28
· Air cleaner element (safety)	Replace	4-28
Hydraulic system		
· Hydraulic oil	Add or Change	4-40, 41
· Hydraulic oil return filter	Replace	4-42
· Drain filter	Replace	4-42
· Pilot line filter element	Replace	4-43
· Hydraulic tank air breather element	Replace	4-42
· Suction strainer	Clean	4-41
· RCV lever	Lubricate	4-45
Undercarriage		
· Track tension	Check, Adjust	4-46
Bucket		
· Tooth	Replace	4-48
· Side cutter	Replace	4-48
· Linkage	Adjust	4-49
· Bucket assy	Replace	4-47
Air conditioner and heater		
· Outer filter	Replace	4-54
· Inner filter	Replace	4-54
Other		
· DEF/AdBlue® tank	Check, Add	4-31
· DEF/AdBlue® supply module filter	Replace	4-33
· DEF/AdBlue® tank filter	Replace	4-32
· DPF (diesel particulate filter)	Clean	4-34

5. MAINTENANCE CHART

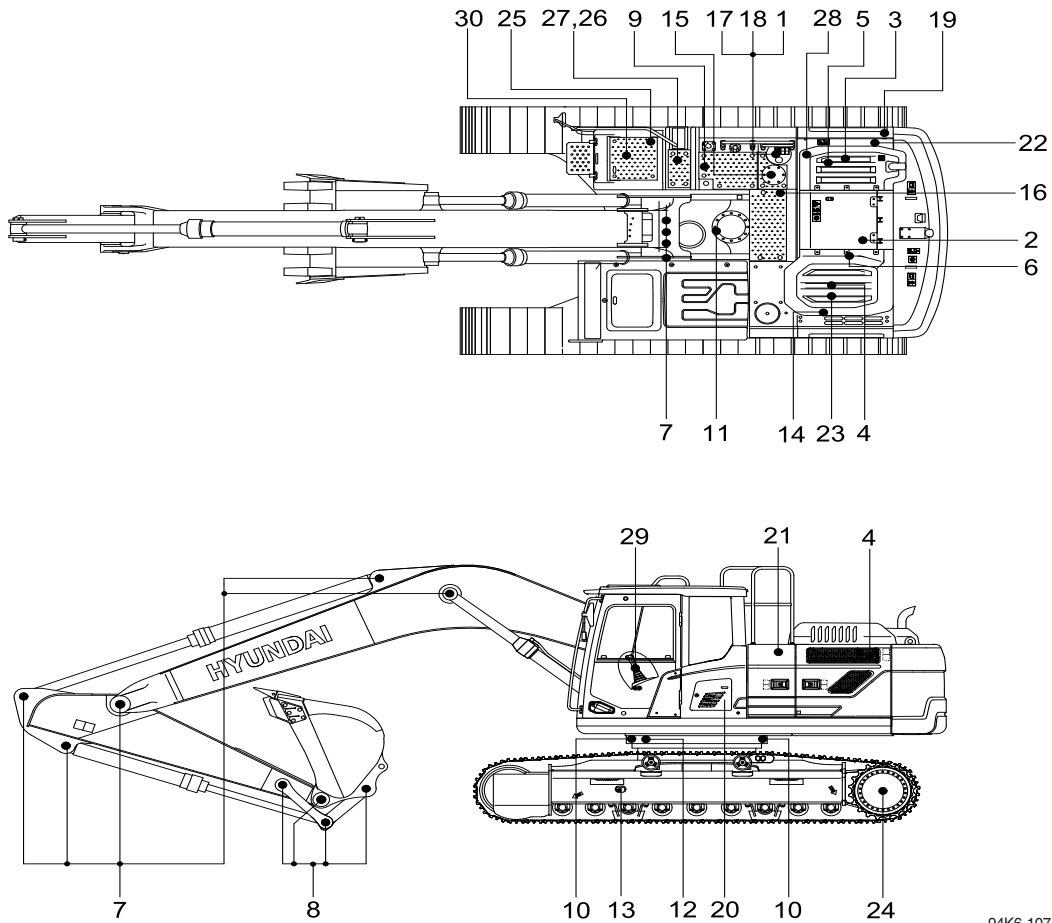

94K6-10710

Caution

1. Service intervals are based on the hour meter reading.
2. The number of each item shows the lubrication point on the machine.
3. Stop engine while filling oil, and do not allow any open flames near the machine.

Service interval	No.	Description	Service action	Oil symbol	Capacity ℓ (U.S.gal)	Service points No.
10 Hours or daily	1	Hydraulic oil level	Check, Add	HO	160 (42.3)	1
	2	Engine oil level	Check, Add	EO	23.1 (6.1)	1
	4	Radiator coolant	Check, Add	C	40 (10.6)	1
	5	Fuel pre-filter	Check, Drain	-	-	1
	6	Fan belt tension and damage	Check, Adjust	-	-	1
	7	★ Attachment pin & bushing	Check, Lubricate	PGL	-	11
	9	Fuel tank	Check, Refill	DF	400 (106)	1
	26	DEF/AdBlue® tank	Check, Add	DEF	48 (12.6)	1

★ Lubricate every 10 hours or daily for initial 100 hours.

※ Oil symbol

Please refer to the recommended lubricants for specification.

DF : Diesel fuel GO : Gear oil HO : Hydraulic oil DEF : DEF/AdBlue®
 C : Coolant PGL : Grease EO : Engine oil

Service interval	No.	Description	Service action	Oil symbol	Capacity ℓ (U.S.gal)	Service points No.
50 Hours or weekly	4	Charge air cooler and piping	Check	-	-	1
	8	Bucket linkage pins	Check, Add	PGL	-	6
	9	Fuel tank (water, sediment)	Check, Drain	-	-	1
	11	Swing reduction gear oil	Check, Add	GO	6.2 (1.6)	1
	13	Track tension	Check, Adjust	PGL	-	2
250 Hours	7	Attachment pins & bushing	Check, Add	PGL	-	11
	10	Swing bearing grease	Lubricate	PGL	-	2
	14	Battery (voltage), battery cable and connections	Check, Clean	-	-	1
	20	Aircon and heater outer filter	Check, Clean	-	-	1
Initial 250 Hours	2	Engine oil	Change	EO	23.1 (6.1)	1
	3	Engine oil filter	Replace	-	-	1
	5	Fuel pre-filter element	Replace	-	-	1
	11	Swing reduction gear oil	Change	GO	6.2 (1.6)	1
	15	Hydraulic oil return filter	Replace	-	-	1
	16	Drain filter	Replace	-	-	1
	19	Pilot line filter element	Replace	-	-	1
	22	Fuel filter element	Replace	-	-	1
500 Hours	20	Travel reduction gear oil	Change	GO	4.5 (1.2)	2
	20	Aircon and heater outer filter	Replace	-	-	1
	20	Aircon and heater inner filter	Replace	-	-	1
	21	Air cleaner element (primary)	Check, Clean	-	-	1
800 Hours	23	Radiator, oil cooler, charge air cooler	Check, Clean	-	-	3
	2	Engine oil	Change	EO	23.1 (6.1)	1
1000 Hours	3	Engine oil filter	Replace	-	-	1
	5	Fuel pre-filter element	Replace	-	-	1
	6	Drive belt, cooling fan	Check	-	-	2
	6	Cooling fan belt tensioner	Check	-	-	1
	11	Swing reduction gear oil	Change	GO	6.2 (1.6)	1
	12	Swing gear and pinion grease	Change	PGL	8.0 kg (17.6 lb)	1
	15	Hydraulic oil return filter	Replace	-	-	1
	16	Drain filter	Replace	-	-	1
	17	Hydraulic tank air breather element	Replace	-	-	1
	19	Pilot line filter element	Replace	-	-	1
	22	Fuel filter element	Replace	-	-	1
24	Travel reduction gear oil	Change	GO	4.5 (1.2)	2	

※ Oil symbol

Please refer to the recommended lubricants for specification.

DF : Diesel fuel

GO : Gear oil

HO : Hydraulic oil

DEF : DEF/AdBlue®

C : Coolant

PGL : Grease

EO : Engine oil

Service interval	No.	Description	Service action	Oil symbol	Capacity ℓ (U.S.gal)	Service points No.
2000 Hours	1	Hydraulic oil* ¹	Change	HO	160 (42.3)	1
	1	Hydraulic oil (HBHO)* ²	Change	HBHO	160 (42.3)	1
	2	Engine cleaning	Clean	-	-	1
	2	Vibration damper (rubber)	Check	-	-	4
	2	Vibration damper (viscous)	Check	-	-	4
	4	Coolant, cooling system and antifreeze	Change, Flush	C	40 (10.6)	1
	18	Hydraulic oil suction strainer	Check, Clean	-	-	1
	21	Air cleaner element (primary, safety)	Replace	-	-	2
	27	DEF/AdBlue® tank filter	Replace	-	-	1
	29	RCV lever	Check, Lubricate	PGL	-	2
	-	Hoses, fittings, clamps (fuel, coolant, hydraulic)	Check, Retighten, Replace	-	-	-
4500 Hours	25	DEF/AdBlue® supply module filter	Replace	-	-	1
5000 Hours	1	Hydraulic oil* ³	Change	HO	160 (42.3)	1
	2	Overhead set (shop inspection)	Adjust	-	-	1
As required	20	Aircon and heater outer filter	Replace	-	-	1
	20	Aircon and heater inner filter	Replace	-	-	1
	21	Air cleaner element (primary)	Clean, Replace	-	-	1
	21	Air cleaner element (safety)	Replace	-	-	1
	28	DPF (diesel particulate filter)	Clean	-	-	1
	30	Fuel filler pump filter	Clean, Replace	-	-	1

*¹ Conventional hydraulic oil *² Hyundai Bio Hydraulic Oil *³ Hyundai genuine long life hydraulic oil

※ Oil symbol

Please refer to the recommended lubricants for specification.

DF : Diesel fuel GO : Gear oil HO : Hydraulic oil DEF : DEF/AdBlue®
C : Coolant PGL : Grease EO : Engine oil

6. SERVICE INSTRUCTION

1) CHECK ENGINE OIL LEVEL

Check the oil level with the machine on flat ground before starting engine.

- (1) Pull out the dipstick and wipe with a clean cloth.
 - (2) Check the oil level by inserting the dipstick completely into the hole and pulling out again.
 - (3) If oil level is LOW, add oil and then check again.
- ※ **If the oil is contaminated or diluted, change the oil regardless of the regular change interval.**
 - ※ **Check oil level after engine has been stopped for 15 minutes.**
 - ▲ **Do not operate unless the oil level is in the normal range.**
 - ※ **Keep all parts clean from contaminants. Contaminants may cause rapid wear and shortened component life.**

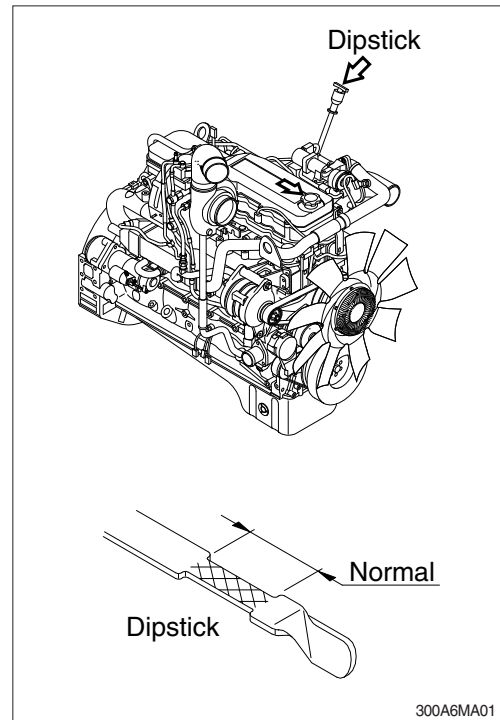

2) REPLACEMENT OF ENGINE OIL AND OIL FILTER

- (1) Operate the engine until the coolant temperature reaches 60°C (140°F). Shut off the engine.
 - (2) Remove the oil drain plug. Drain the oil immediately to be sure all the oil and suspended contaminants are removed from the engine.
- ※ **A drain pan with a capacity of 30 liters (7.9 U.S. gallons) will be adequate.**
 - ※ **Dispose of the waste oil in accordance with local regulations.**
- (3) Clean the area around the lubricating oil filter head.
 - (4) Use oil filter wrench to remove the oil filter.
 - (5) Clean the gasket surface of oil filter head.
- ※ **The O-ring can stick on the filter head. Be sure it is removed before installing the new filter.**

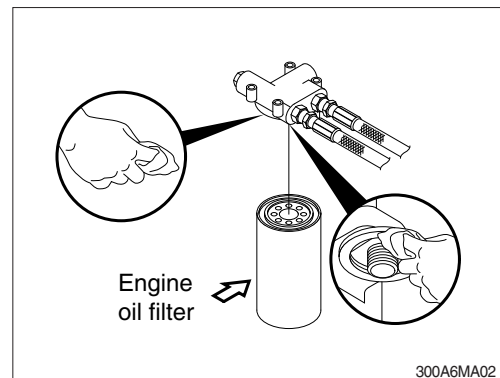
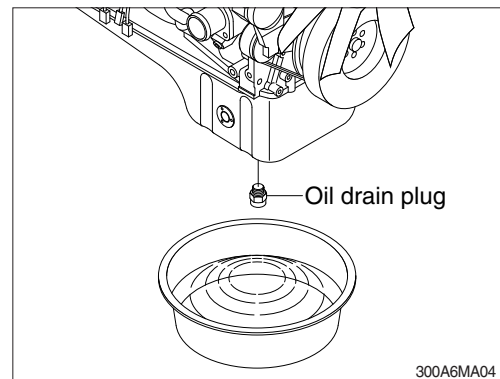

- (6) Apply a light film of lubricating oil to the gasket sealing surface before installing the filter.
 ※ **Fill the filter with clean lubricating oil.**

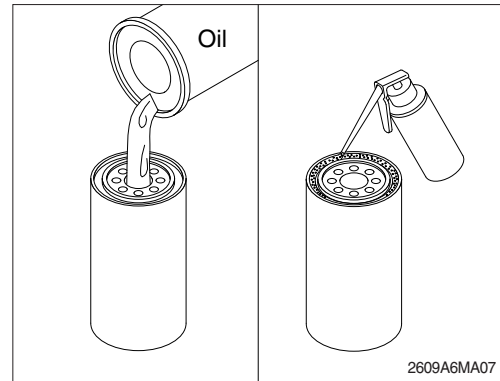

- (7) Install the filter to the filter head.
 Tighten the filter until the gasket contacts the filter head surface.
 Tighten 3/4 to 1 turn after the gasket makes contact with the filter head.
 ※ **Mechanical over-tightening may distort the threads or damage the filter element seal.**

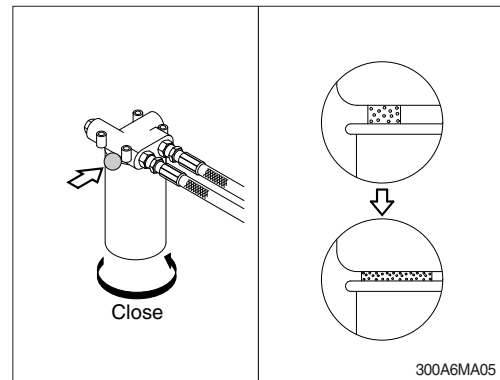

- (8) Clean and check the lubricating oil drain plug threads and sealing surface.
 Install the lubricating oil pan drain plug.
 (9) Fill the engine with clean oil to the proper level.
 · Quantity : 23.1 ℓ (6.1 U.S.gallons)

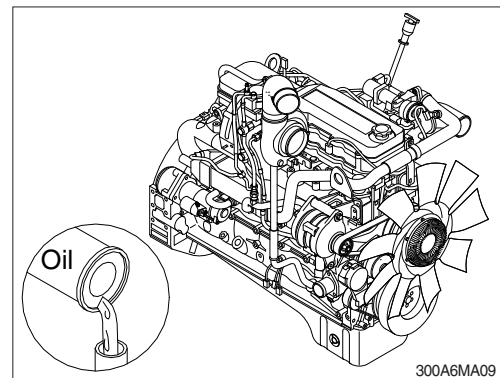

- (10) Operate the engine at low idle and inspect for leaks at the filters and the drain plug.
 Shut the engine off and check the oil level with the dipstick. Allow 15 minutes for oil to drain down before checking.

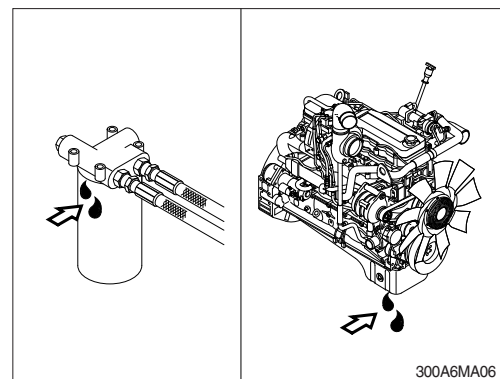

3) CHECK RADIATOR COOLANT

- (1) Check if the level of coolant in reservoir tank is between FULL and LOW.
- (2) Add the mixture of antifreeze and water after removing the cap of the reservoir tank if coolant is not sufficient.
- (3) Be sure to use the reservoir empty, add the coolant by opening the cap of surge tank.
- (4) Replace gasket of radiator cap when it is damaged.

▲ Hot coolant can spray out if surge tank cap is removed while engine is hot. Remove the cap after the engine has cooled down.

※ Do not add cold coolant to a hot engine ; engine castings can be damaged. Allow the engine to cool to below 50 °C (120 °F) before adding coolant.

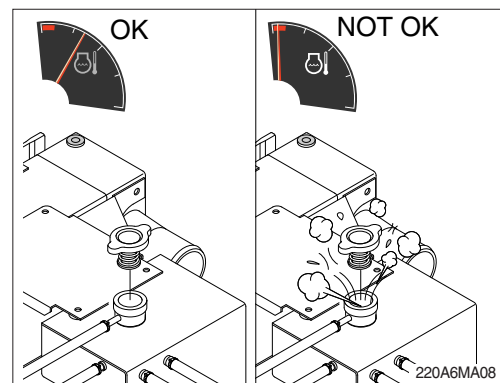
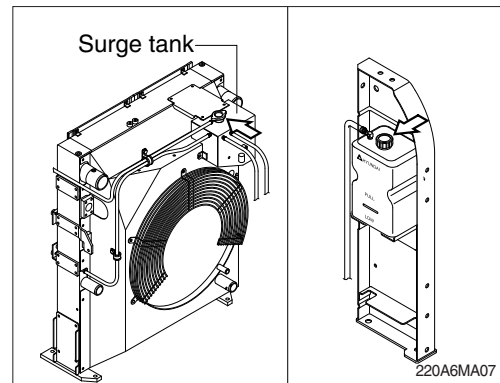

4) FLUSHING AND REFILLING OF RADIATOR

- (1) Change radiator coolant

▲ Avoid prolonged and repeated skin contact with used antifreeze. Such prolonged and repeated contact can cause skin disorders or other bodily injury.

Avoid excessive contact-wash thoroughly after contact is made.

Keep out of reach of children.

※ Protect the environment : Handling and disposal of used antifreeze can be subject to federal, state, and local law regulation.

Use authorized waste disposal facilities, including civic amenity sites and garages providing authorized facilities for the receipt of used antifreeze.

If in doubt, contact your local authorities for guidance as to proper handling of used antifreeze.

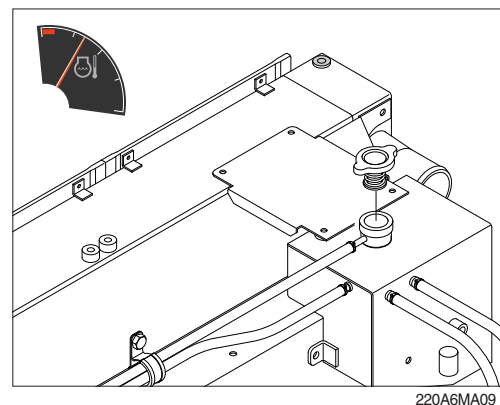

- ▲ Wait until the temperature is below 50 °C (122 °F) before removing the coolant system pressure cap.

Failure to do so can cause personal injury from heated coolant spray.

Drain the cooling system by opening the drain valve on the radiator and opening the drain valve on the bottom of the engine oil cooler housing.

A drain pan with a capacity of 57 liters (15 U.S. gallons) will be adequate.

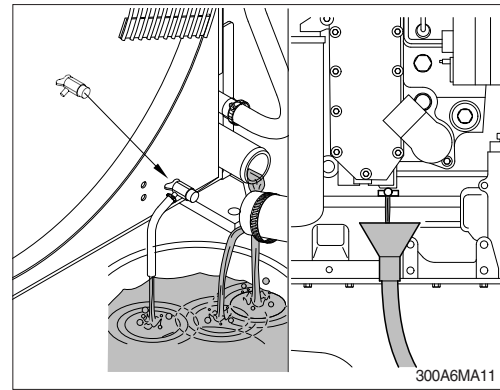

(2) Flushing of cooling system

- ① Fill the system with a mixture of sodium carbonate and water (or a commercially available equivalent).

※ Use 0.5 kg (1.0 pound) of sodium carbonate for every 23 liters (6.0 U.S. gallons) of water.

※ Do not install the surge tank cap. The engine is to be operated without the cap for this process.

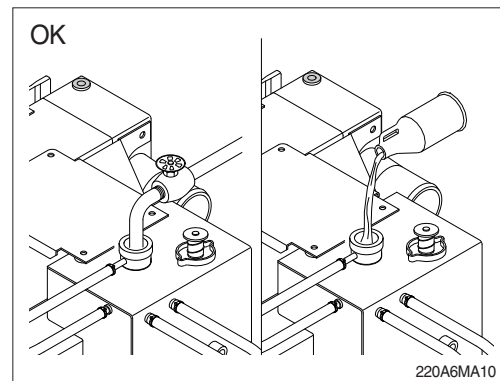

※ During filling, air must be vented from the engine coolant passages.

The system must be filled slowly to prevent air locks or serious engine damage can result. Wait 2 to 3 minutes to allow air to be vented, then add mixture to bring the level to the top.

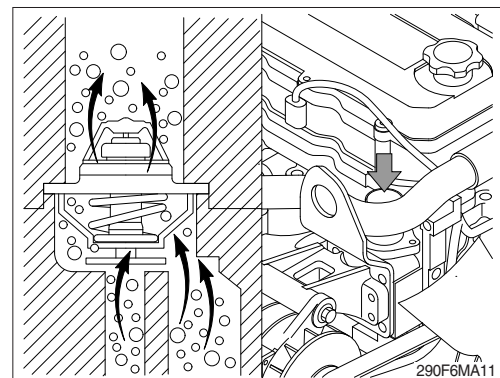

- ② Operate the engine for 5 minutes with the coolant temperature above 80°C (176°F).

Shut the engine off, and drain the cooling system.

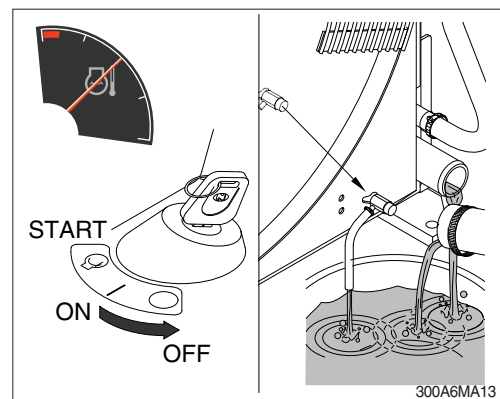

- ③ Fill the cooling system with clean water.
- ※ **Be sure to vent the engine and aftercooler for complete filling.**
- ※ **Do not install the surge tank cap or the new coolant filter.**

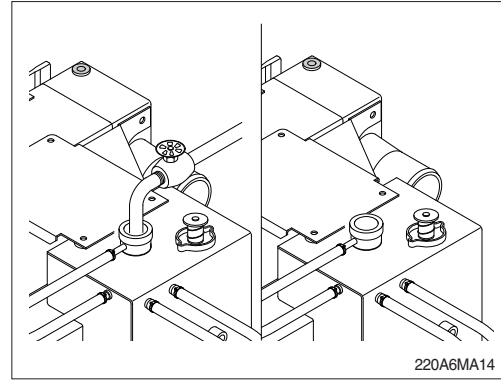

- ④ Operate the engine for 5 minutes with the coolant temperature above 80°C (176°F). Shut the engine off, and drain the cooling system.
- ※ **If the water being drained is still dirty, the system must be flushed again until the water is clean.**

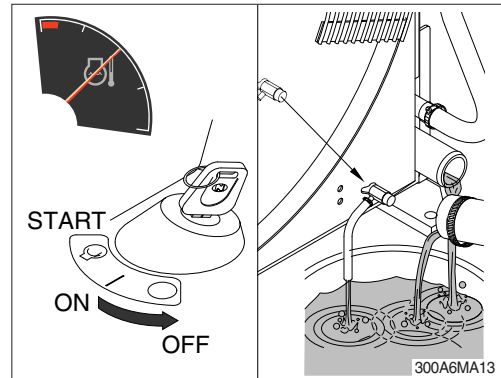

(3) Cooling system filling

- ① Use a mixture of 50 percent soft water and 50 percent ethylene glycol antifreeze to fill the cooling system. Refer to page 4-10. Coolant capacity (engine only) : 10 ℓ (2.6 U.S. gallons)
- ※ **Do not use hard water such as river water or well water.**

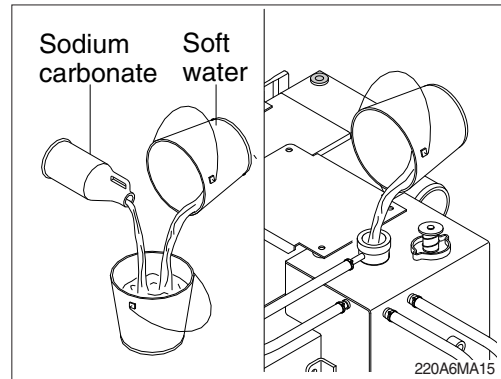

- ② The system has a maximum fill rate of 19 liters (5.0 U.S. gallons) per minute. Do not exceed this fill rate.
- ※ **The system must be filled slowly to prevent air locks.** During filling, air must be vented from the engine coolant passage.

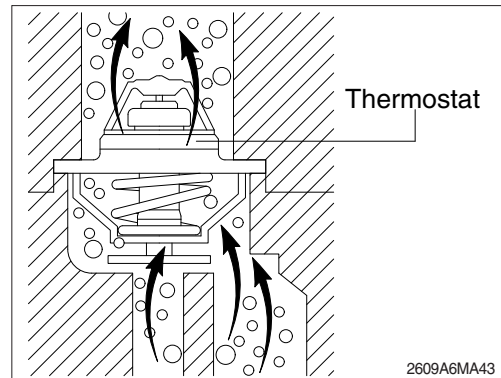

- ③ Install the pressure cap. Operate the engine until it reaches a temperature 80°C (176°F), and check for coolant leaks.

Check the coolant level again to make sure the system is full of coolant after allow engine to cool.

- ※ If the gasket of the surge tank cap is damaged, discard the old filler cap and install a new cap.

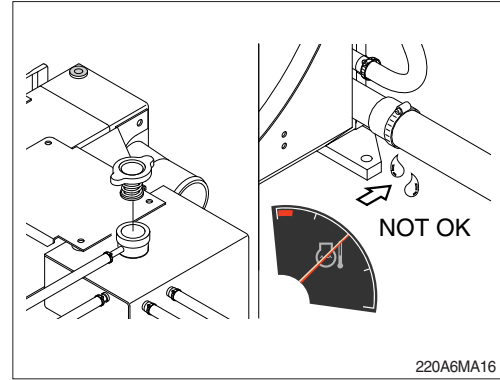

5) CLEAN RADIATOR AND OIL COOLER

Check, and if necessary, clean and dry outside of radiator and oil cooler. After working in a dusty place, clean radiator more frequently.

- (1) Visually inspect the radiator for clogged radiator fins.
- (2) Use 550 kPa (80 psi) air pressure to blow the dirt and debris from the fins.
- (3) Visually inspect the radiator for bent or broken fins.

- ※ **If the radiator must be replaced due to bent or broken fins which can cause the engine to overheat, refer to the manufacturer's replacement procedures.**

- (4) Visually inspect the radiator for core leaks.

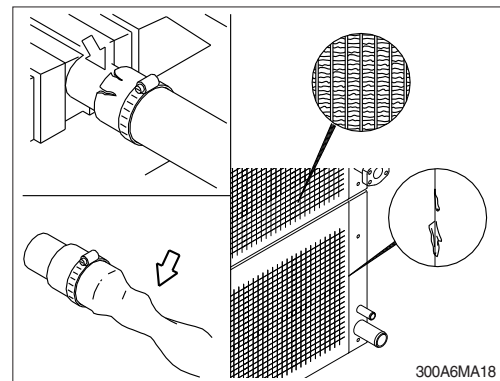
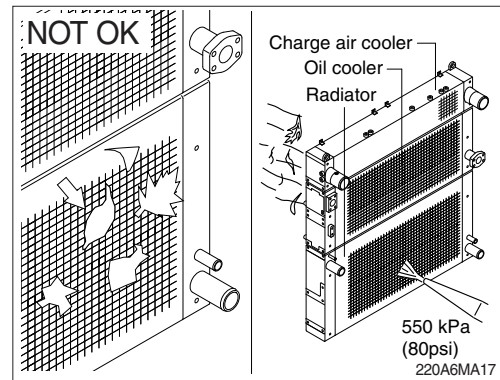

6) CHECK CHARGE AIR COOLER

Inspect the charge air cooler for dirt and debris blocking the fins. Check for cracks, holes, or other damage. If damage is found, please contact your local Hyundai dealer.

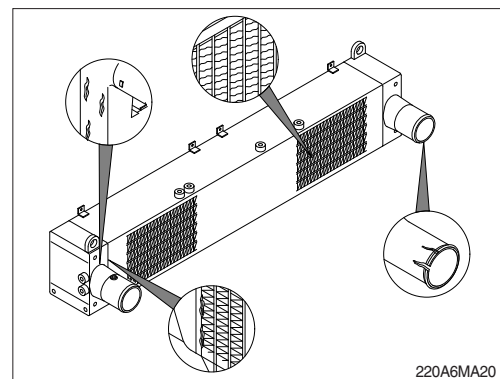

7) FAN BELT

- (1) A deflection method can be used to check belt tension by applying 11.3 kgf (25 lbf) of force between the pulleys on V-belts. If the deflection is more than one belt thickness per foot of pulley center distance, the belt tension must be adjusted.

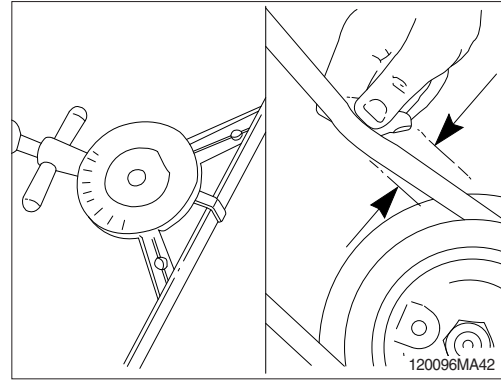

- (2) Inspect the fan belt for damage.

- ① Transverse (across the belt) cracks are acceptable.
- ② Longitudinal (direction of belt ribs) cracks that intersect with transverse cracks are not acceptable.

Replace the belt if it is frayed or has pieces of material missing.

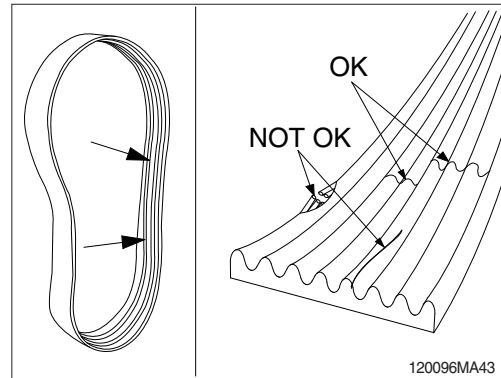

- (3) Inspect the idle and drive pulleys for wear or cracks.

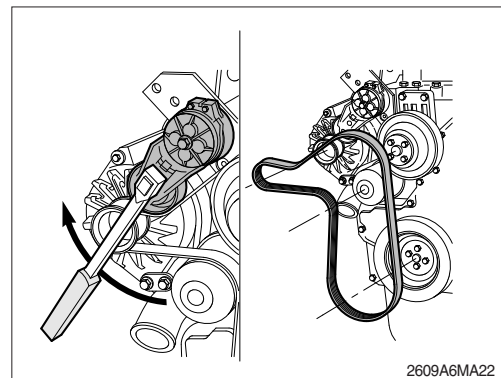

8) INSPECTION OF COOLING FAN

▲ Serious injury can result from a fan blade failure. Never pull or pry on the fan. This can damage the fan blade and cause fan failure.

※ Rotate the crankshaft by using the engine bearing gear.

※ A visual inspection of the cooling fan is required daily.

Check for cracks, loose rivets, and bent or loose blades.

Check the fan to make sure it is securely mounted. Tighten the capscrews if necessary.

Replace any fan that is damaged.

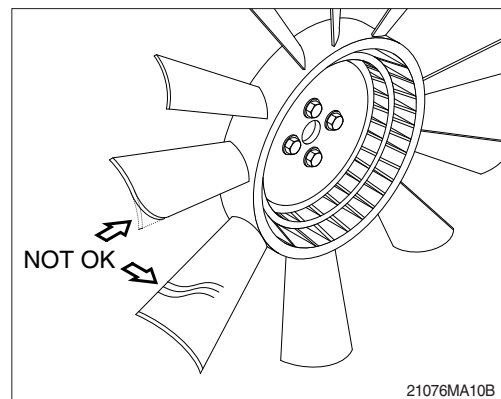

9) FAN BELT TENSIONER

- (1) With the engine stopped, check the tensioner arm, pulley, and stops for cracks. If any cracks are found, the tensioner must be replaced.

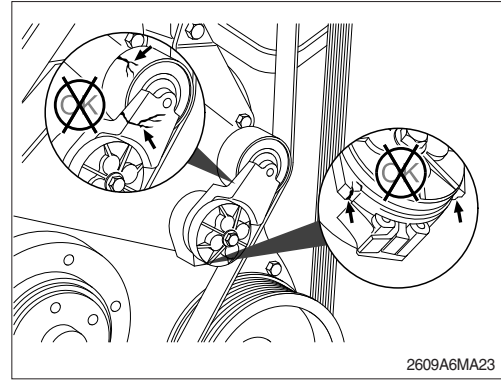

- (2) With the belt installed, verify that neither tensioner arm stop is in contact with the spring case stop.

After replacing the belt, if the tensioner arm stops are still in contact with the spring case stop, replace the tensioner.

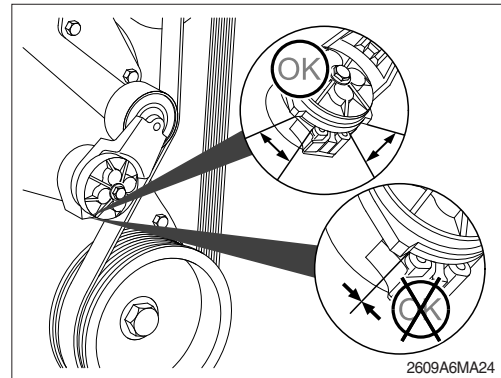

- (3) With the belt removed, verify that the tensioner arm stop is in contact with the spring case stop. If these two are not touching, the tensioner must be replaced.

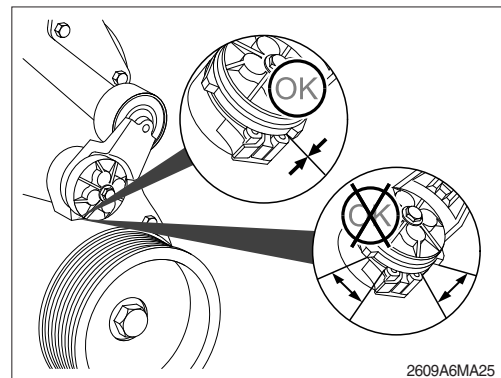

- (4) Check the location of the drive belt on the belt tensioner pulley. The belt should be centered on, or close to the middle of the pulley. Misaligned belts, either too far forward or backward, can cause belt wear, belt roll-offs, or increase uneven tensioner bushing wear.

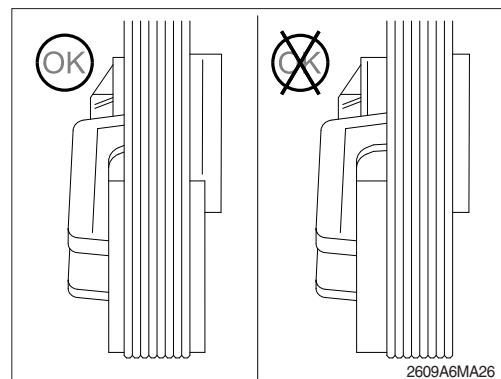

10) CLEANING OF AIR CLEANER

(1) Primary element

- ① Loosen the clamps and remove the element.
 - ② Clean the inside of the body.
 - ③ Clean the element with pressurized air.
 - Remove the dust inside of the element by the pressurized air (below 3 kgf/cm², 40 psi) forward and backward equally.
 - ④ Inspect for cracks or damage of element by putting a light bulb inside of the element.
 - ⑤ Insert element and tighten the clamps.
- ※ **Replace the primary element after 4 cleanings.**

(2) Safety element

- ※ **Replace the safety element only when the primary element is cleaned 4 times.**
- △ **Always replace the safety element. Never attempt to reuse the safety element by cleaning the element.**

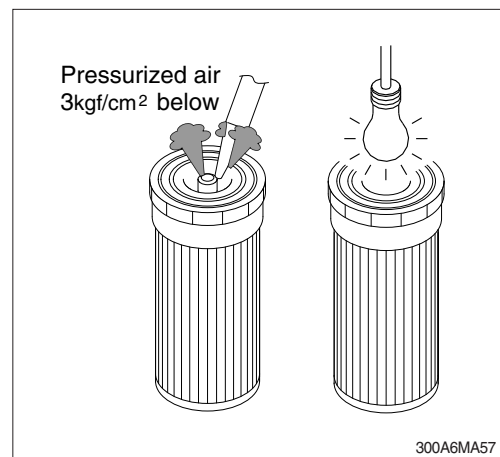
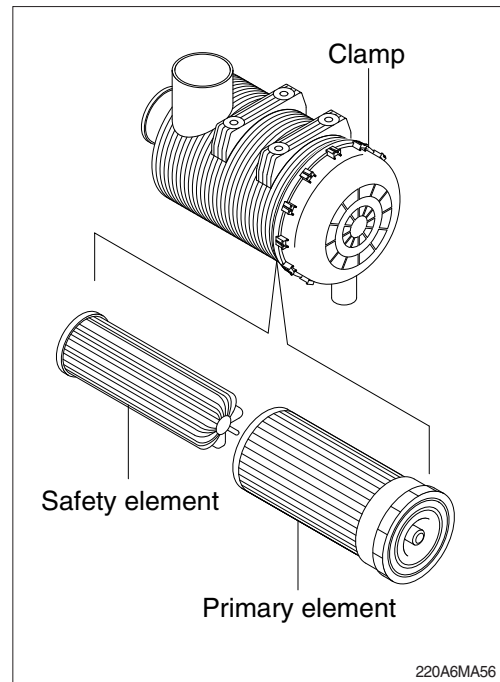

11) FUEL TANK

- ※ **Remove the strainer of the fuel tank and clean it if contaminated.**
- (1) Fill fuel tank fully to minimize water condensation and check the fuel gauge level before starting the machine.
 - (2) Drain the water and sediment in the fuel tank by opening the drain cock.
- ※ **Be sure to LOCK the cap of fuel tank.**
- ▲ **Stop the engine when refueling.**
All lights and flames shall be kept at a safe distance while refueling.

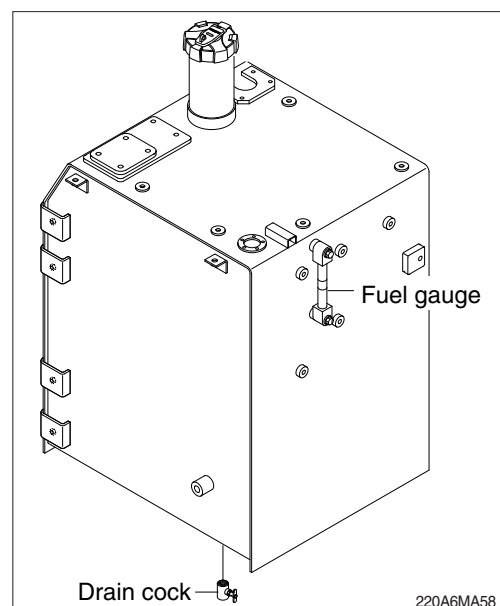

12) FUEL PRE-FILTER

- ※ Inspect or drain the collected water daily and replace the element every 1000 hours.

(1) Drain water

- ① Open the drain valve to evacuate water for 10 seconds.
 - ② Close drain valve.
- ※ Do not use tools.
 - ※ Do not overtighten drain valve.

(2) Replace element

- ① Loosen the air vent plug and drain the unit of fuel. Follow "Drain water" instructions above.
- ② Remove the drain pipe and WIF sensor.
- ③ Remove the element from the filter head.
- ④ Pre-fill a new element body with fuel and lubricate gasket on the new element.
- ⑤ Install the new element on the filter head. Tighten the new element until the gasket contacts the filter head surface. Tighten the new element an additional 3/4 turn.
- ⑥ Connect the drain pipe and WIF sensor to filter body.

(3) Air bleeding

- ① Hand-prime the lift pump repeatedly until air bubbles comes out from air vent hole completely.
- ② Tighten the air vent plug.

- ▲ The fuel pump, high-pressure fuel lines, and fuel rail contain very high-pressure fuel. Do not loosen any fittings while the engine is running. Failure to comply may result in serious injury or death. Wait at least 10 minutes after shutting down the engine before loosening any fittings in the high-pressure fuel system to allow pressure to decrease.

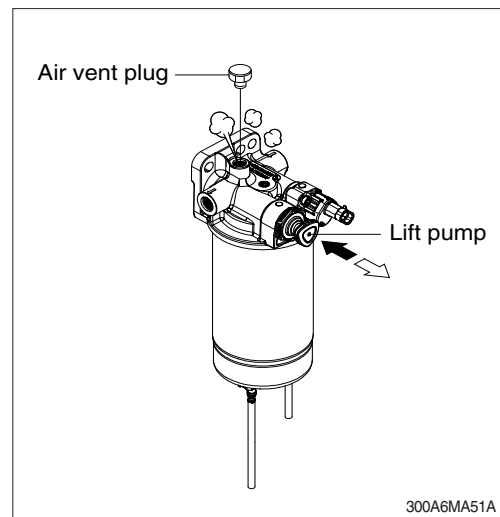
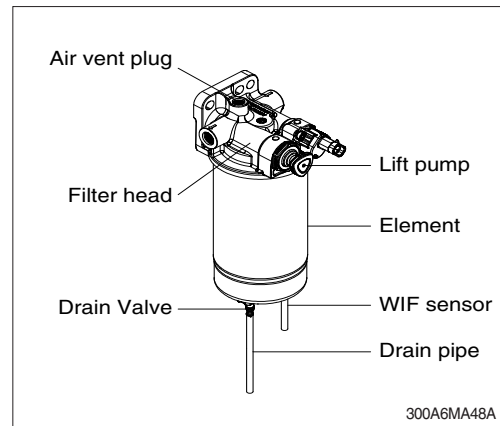

13) CHARGE AIR PIPING

- (1) Inspect the charge air piping and hoses for leaks, holes, cracks, or loose connections.
- (2) Tighten the hose clamps if necessary.

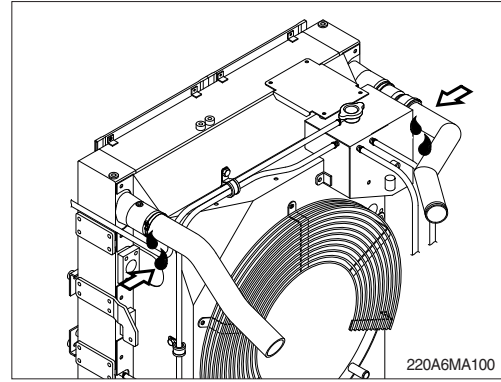

14) REPLACEMENT OF FUEL FILTER ELEMENT

- (1) Use 1" wrench, loosen and remove the element and clean the gasket surface.
 - ※ **Make sure O-ring does not stick to filter head. Remove O-ring with screwdriver if necessary.**
- (2) Lubricate O-ring of a new element with clean lubricating oil.
- (3) Install the new element on the filter head. Tighten the new element until the gasket contacts the filter head surface. Tighten the new element an additional 3/4 turn after contact.
 - ※ **Mechanical overtightening can distort the threads or damage the filter element seal.**
- (4) Relieve the air after mounting.
 - ※ **Do not pre-fill the new element with fuel. The system must be primed after the new element is installed. Pre-filling the new element can result in debris entering the fuel system and damaging fuel system components.**
 - ※ **Check for fuel leakage after the engine starts. If air is in the fuel system, the engine will not start. Start engine after bleeding the air according to the method of bleeding air.**

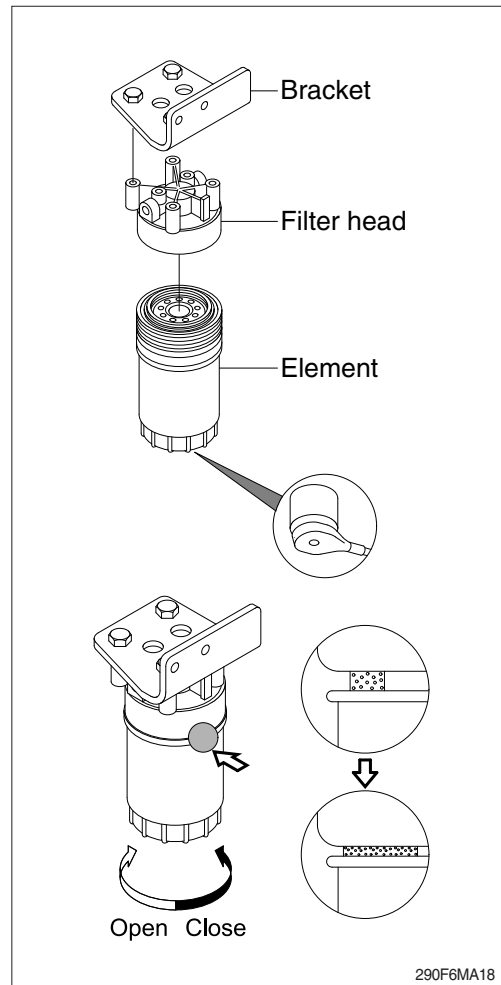

15) LEAKAGE OF FUEL

- ▲ Use care when cleaning the fuel hose, injection pump, fuel filter and other connections as the leakage from these parts can cause fire.

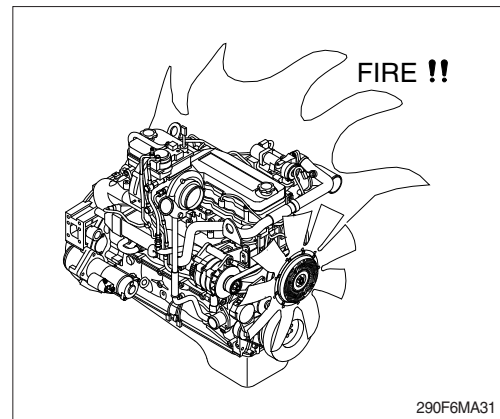

16) DEF/AdBlue® TANK

- (1) The DEF/AdBlue® tank level must be checked daily with DEF/AdBlue® level gauge.
- (2) If the DEF/AdBlue® level gauge is low, DEF/AdBlue® must be added.
 - ▲ It is unlawful to tamper with or remove any component of the aftertreatment system. It is also unlawful to use a catalyst solution that does not meet the specifications provided or operate the machine with no catalytic solution.

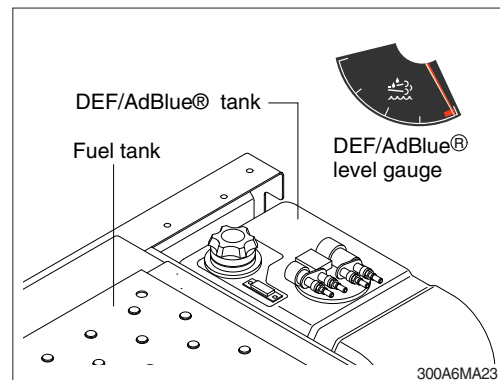

- (3) Do not pour DEF/AdBlue® overfull.
 - ※ Fill the tank with DEF/AdBlue® with key in the start position.
 - ※ Be careful when filling or refilling DEF/AdBlue® tank. Do not allow dust, sand or other contaminants to enter into the tank. Failure to comply could result in engine idle locking, derating, or engine stopping.

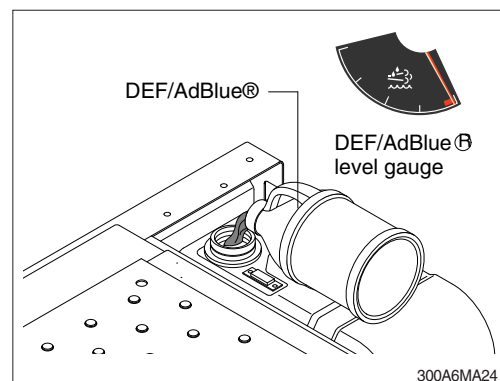

17) DEF/AdBlue® TANK FILTER

- (1) The filter is located on the top side of the tank cover.

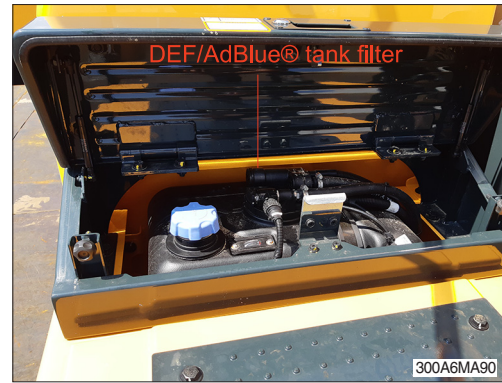

- (2) Insert a hex wrench into the filter cover, rotate it anti-clockwise and remove the filter cover.



- (3) Pull out the filter by using a long nose pliers.

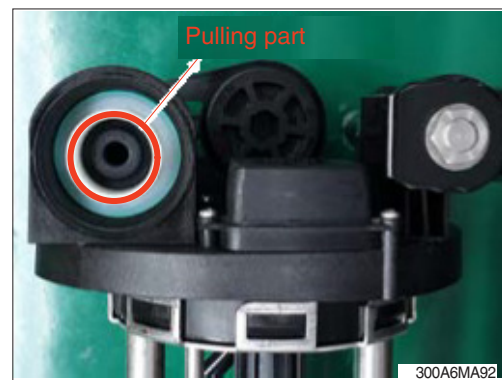

- (4) Replace with a new filter.



(5) Place the filter cover and rotate the cover clockwise by using hex wrench.

※ Replace the filter every 2000 hours.

※ If the filter is reused, take care not to damage the thread part of the filter with long nose pliers. Use protection material such as a cloth etc to grip part of the filter by the long nose pliers.

※ Be careful not to cross-thread during reassembly.



18) DEF/AdBlue® SUPPLY MODULE FILTER

(1) Inspect the area around the DEF/AdBlue® supply module filter case for signs of leakage.

※ Turn OFF the master switch mounted electric box.

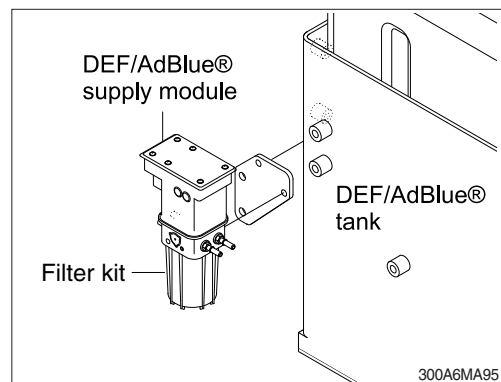

(2) Remove the filter case with the biotube pump spray and filter.

(3) Remove the filter and biotube pump spray from the case.

※ Clean the case inside and biotube pump spray.

(4) Insert a new filter and biotube pump spray into the case and tighten the case.

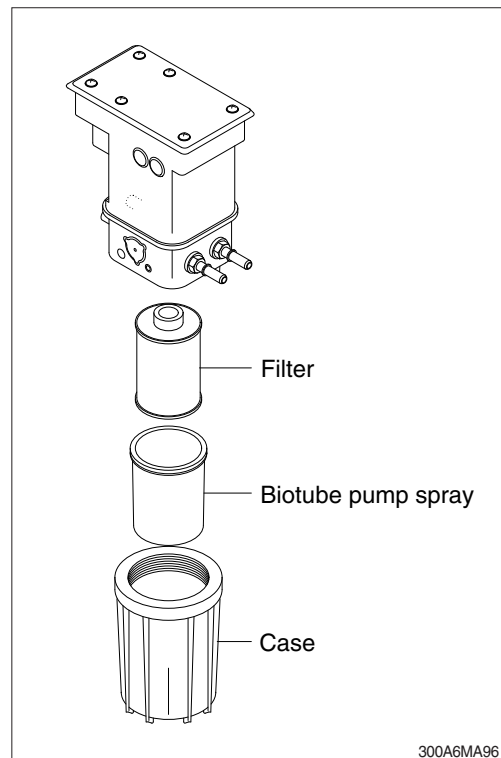

19) ENGINE CLEANING

⚠ When using a steam cleaner, wear safety glasses or a face shield, as well as protective clothing. Hot steam can cause serious personal injury.

- ※ Turn OFF the master switch mounted electric box.
- ※ Spraying high pressure steam near or into electrical components can cause damage.

- (1) Steam is the recommended method of cleaning a dirty engine or a piece of equipment.
- (2) Protect all electrical components, openings, and wiring from the full force of the spray nozzle.
- (3) Components to protect include, but are not limited to the following:
 - Electrical components and connectors
 - Wiring harnesses
 - Electronic control module (ECM) and connectors.
 - Belts and hoses
 - Bearings (ball or taper roller)

△ Soap, solvent, or water ingress into air intake system can cause engine damage.

△ Do not directly spray or allow soap, solvent, or water to enter any passages, ports, or cowlings that lead to the engine air intake system.

20) DPF (diesel particulate filter) CLEANING

- (1) The diesel particulate filter can not be cleaned for maintenance purpose using conventional tools.
 - (2) The diesel particulate filter needs to be cleaned and checked using an approved cleaning machine at a authorized service center.
- ※ Please contact your Hyundai service center or your local Hyundai dealer.

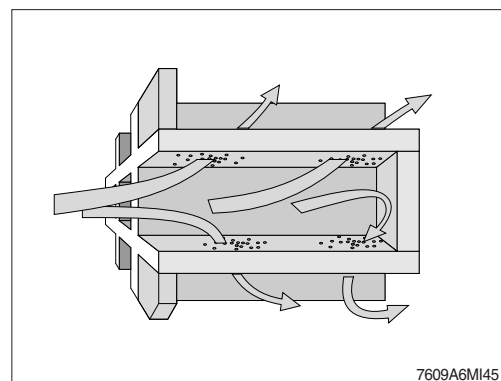
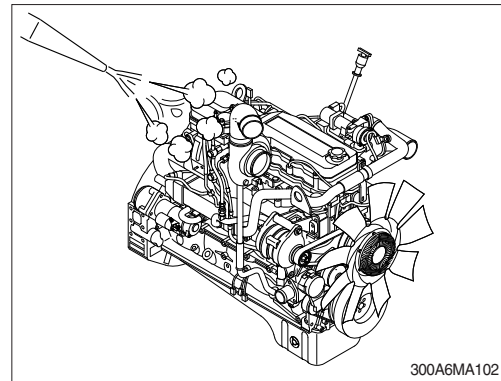

21) VIBRATION DAMPER

(1) Rubber

- ① Check the index lines (A) in the vibration damper hub (B) and the inertia member (C). If the lines are more than 1.59 mm (1/16 in) out of alignment, replace the vibration damper.

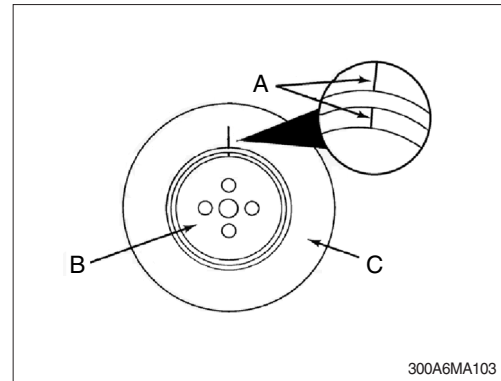

- ② Inspect the rubber member for deterioration. If pieces of rubber are missing or if the elastic member is more than 3.18 mm (1/8 in) below the metal surface, replace the damper.
- ③ Look for forward movement of the damper ring on the hub. Replace the vibration damper if any movement is detected.

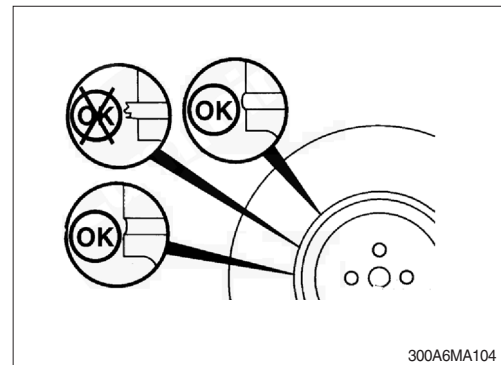

(2) Viscous

※ **The silicone fluid in the vibration damper will become solid after extended service and will make the damper inoperative. An inoperative vibration damper can cause major engine or drivetrain failures.**

- ① Check the vibration damper for evidence of fluid loss, dents, and wobble. Inspect the vibration damper thickness for any deformation or raising of the damper cover plate.
- ② If any of these conditions are identified, contact your local Hyundai dealer to replace the vibration damper when movement is detected.

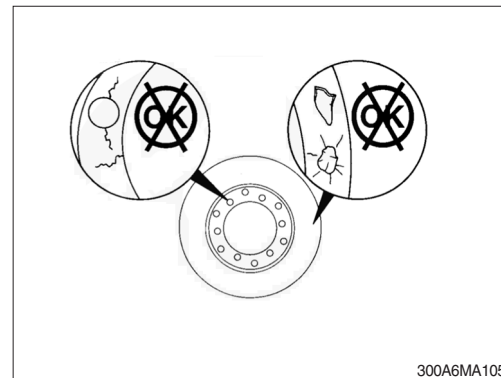

22) OVERHEAD SET ADJUSTMENT

- ※ These procedures are performed at repair shop.
- ※ **Service tools**
 - Cummins barring tool, p/no. 5299073
 - Feeler gauge
- ※ **Remove the rocker lever cover and gasket, refer to engine maintenance manual.**

- (1) Use the barring tool, to rotate the crankshaft until the number 1 cylinder is at topdead center (TDC).

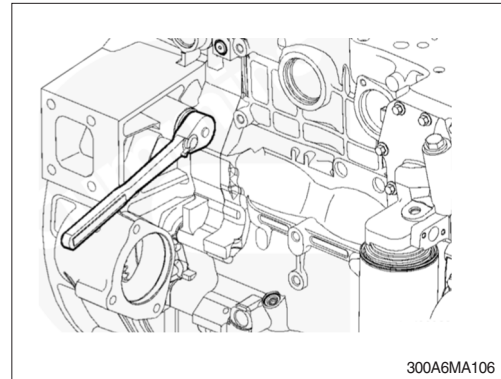

- (2) The TDC indicator is on the vibration damper. Align the vibration damper so the TDC indicator is at the 12 o'clock position.

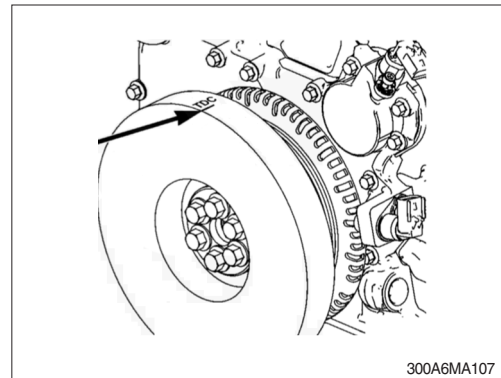

- ※ If no TDC mark is present on either the vibration damper or the crankshaft speed indicator ring, align the large gap in the crankshaft speed indicator ring to the 5 o'clock position (2). The dowel pin will be visible in the 9 o'clock position (1). Check that both number 1 cylinder rocker levers are loose. If they are not loose, rotate the crankshaft 360 degrees and check again.

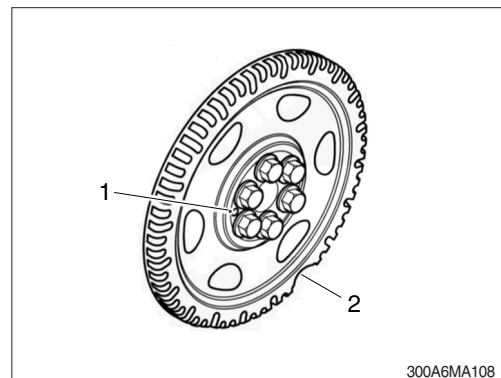

- (3) If both of the number 1 cylinder rocker levers are loose, proceed to the next step; If the number 1 cylinder rocker levers are not loose, rotate the crankshaft 360 degrees and proceed to the next step.

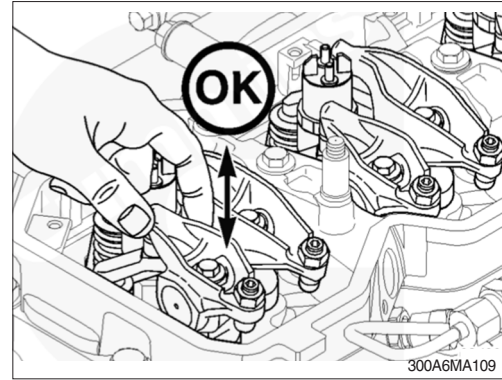

- (4) Make sure to check the engine dataplate for correct valve lash (overhead set) specifications. The engine dataplate is typically located on the engine rocker lever cover, but may also be located on the left side of the gear housing.

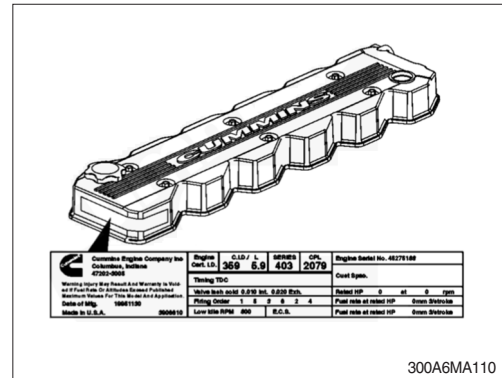

- (5) If the number 1 cylinder is at TDC and both rocker levers are loose, the valve lash (overhead set) can be checked on the following rocker levers:
(E = exhaust, I = Intake)
1I, 1E, 2I, 3E, 4I, and 5E.

Overhead set check limits

Item		mm	inch
Intake	Min	0.152	0.006
	Max	0.381	0.015
Exhaust	Min	0.381	0.015
	Max	0.762	0.030

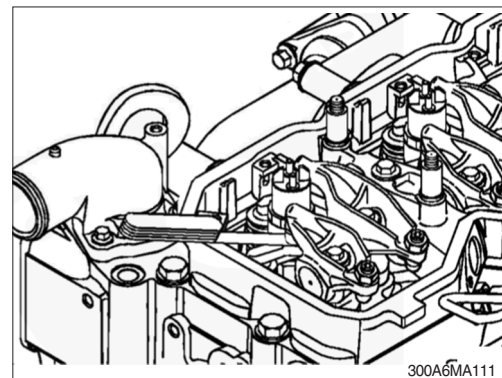

- (6) Checking the overhead setting is usually performed as part of a troubleshooting procedure, and resetting is not required during checks, as long as the lash measurements are within the specifications shown above.

- (7) The clearance is correct when some resistance is felt when the feeler gauge is slipped between the crosshead and the rocker lever socket. Measure the valve lash (overhead set) by inserting a feeler gauge between the crosshead and the rocker lever socket. If the measurement is out of specification, loosen the locknut and adjust the lash to nominal specifications.

Overhead set valve lash

Item		mm	inch
Intake	Nominal	0.254	0.010
Exhaust	Nominal	0.508	0.020

- ※ **Tighten the lock nut and measure the clearance again.**

Tightening torque : 2.4 kgf·m (17.4 lbf·ft)

- (8) Use the barring tool, to rotate the crankshaft 360 degrees.
Use the previous steps and specifications to set the valve lash on the following rocker levers:
(E = exhaust, I = Intake)
2E, 3I, 4E, 5I, 6I, and 6E.

If the measurements are out of specification, set the valve lash.

- (9) Install the rocker lever cover gasket and cover, refer to engine maintenance manual.

- (10) Operate the engine. Check for leaks.

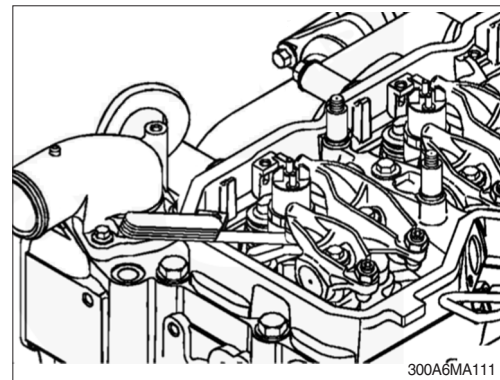
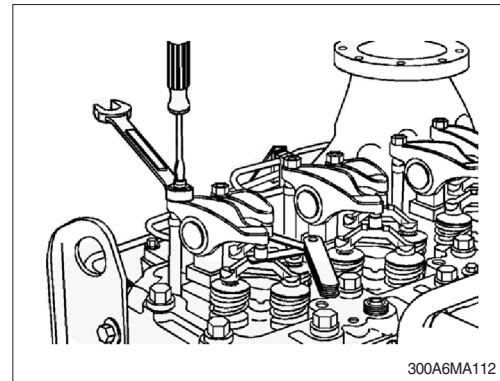

23) FUEL FILLER PUMP FILTER

Clean the filter periodically as followings.

- (1) Clean the filter when it is required by visual inspection.
- (2) Replace the filter when it is permanently damaged.

※ Clean with fuel or compressed, water should not be mixed.

※ The structure can be loosened by hand.

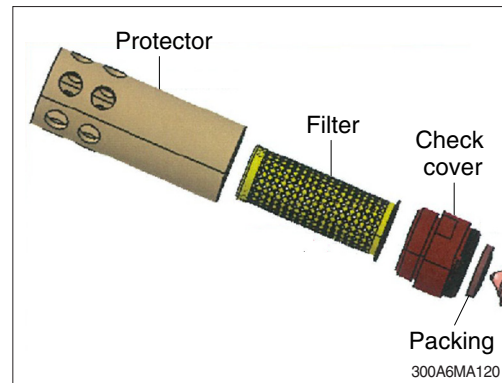

(3) Check valve

- ① Except for maintenance, the check valve must have been equipped to the hose at all times.
- ② Clean or replace check valve when foreign material is found in valve.

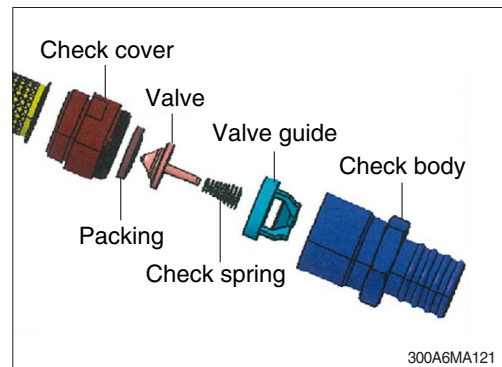

24) HYDRAULIC OIL CHECK

- (1) Position the machine as shown in the illustration on the right. Then stop engine.
- (2) Check the oil level at the level gauge of hydraulic oil tank.
- (3) The oil level is normal if between the red lines.

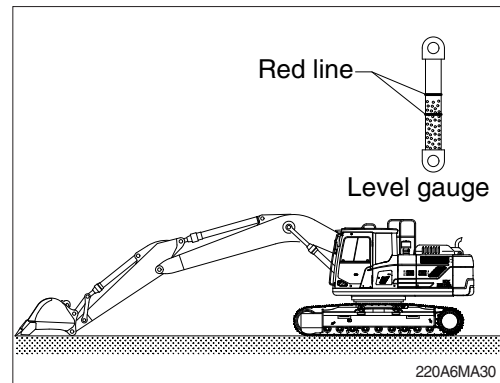

25) FILLING HYDRAULIC OIL

- (1) Position the machine like the hydraulic oil check. Then stop engine.
- (2) Relieve the pressure in the tank by pushing the top of the air breather.
- (3) Loosen the socket bolts and remove the air breather on the top of oil tank and fill the oil to the specified level.
 - Tightening torque : $4.05 \pm 0.8 \text{ kgf} \cdot \text{m}$
($29.3 \pm 5.8 \text{ lbf} \cdot \text{ft}$)
- (4) Start engine after filling and operate the work equipment several times.
- (5) Check the oil level at the level check position after engine stops.

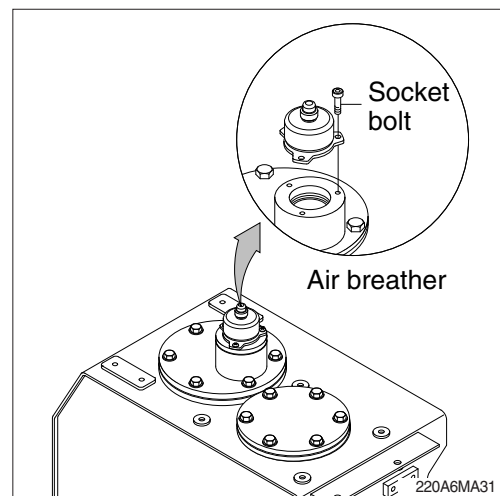

26) CHANGE HYDRAULIC OIL

- (1) Position the machine like the hydraulic oil check. Then stop engine.
 - (2) Relieve the pressure in the tank by pushing the top of the air breather.
 - (3) Remove the cover.
 - Tightening torque : $6.9 \pm 1.4 \text{ kgf} \cdot \text{m}$
($50 \pm 10 \text{ lbf} \cdot \text{ft}$)
 - (4) Prepare a suitable container with a capacity of 275 l (72.6 U.S. gal).
 - (5) To drain the oil open the drain valve at the bottom of the oil tank.
 - (6) Close the drain valve and fill proper amount of recommended oil.
 - (7) Put the breather in the right position.
 - (8) To bleed air from hydraulic pump loosen the air breather at top of hydraulic pump assembly.
 - (9) Start engine and run continually. Release the air by full stroke of each control lever.
- ※ In case of injecting HBHO (Hyundai Bio Hydraulic Oil) to machines that have formerly used different hydraulic oil, the proportion of residual oil must not exceed 2 %.
- ※ Do not mix any other Bio oil, use only HBHO as bio oil. If changing to Bio oil, contact your local Hyundai dealer.

27) CLEAN SUCTION STRAINER

Clean suction stainer as follows.

- (1) Remove the cover.
 - Tightening torque : $6.9 \pm 1.4 \text{ kgf} \cdot \text{m}$
($50 \pm 10 \text{ lbf} \cdot \text{ft}$)
 - (2) Pull out the strainer in the tank.
 - (3) Wash the suction strainer with gasoline or cleaning oil (mineral spirits).
 - (4) Replace the suction strainer if it is damaged.
 - (5) Assemble with reverse order of disassembly. Be sure to install a new O-ring.
- ※ Loosen bolts on the cover slowly as the cover has spring force applied. This will prevent cover from popping off without notice.

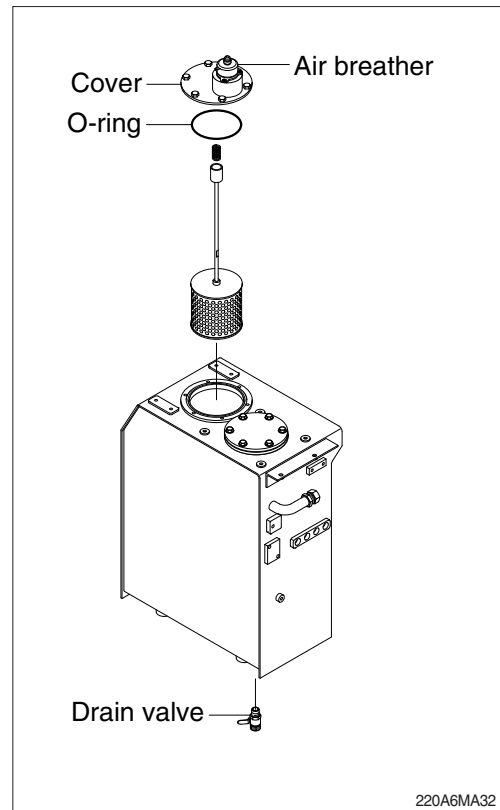

220A6MA32

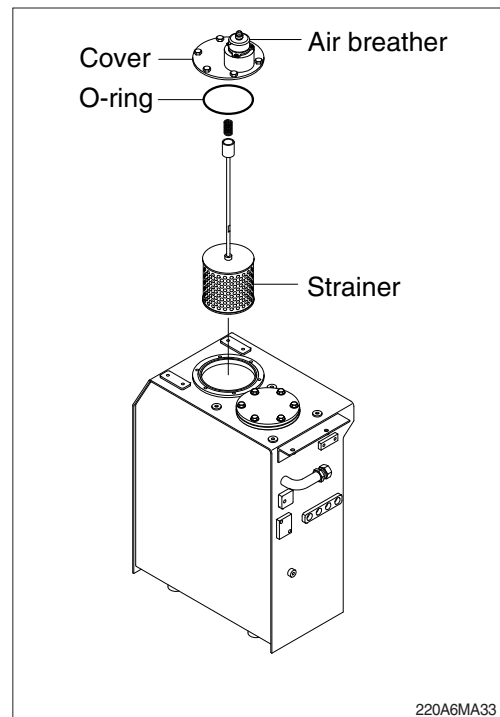

220A6MA33

28) REPLACEMENT OF RETURN FILTER

Replace return filter as follows.

- (1) Remove the cover.
- (2) Remove the spring, by-pass valve and return filter in the tank.
- (3) Replace the return filter with a new one.
- (4) Reassemble by reverse order of disassembly.
 - Tightening torque : $6.9 \pm 1.4 \text{ kgf} \cdot \text{m}$
($50 \pm 10 \text{ lbf} \cdot \text{ft}$)

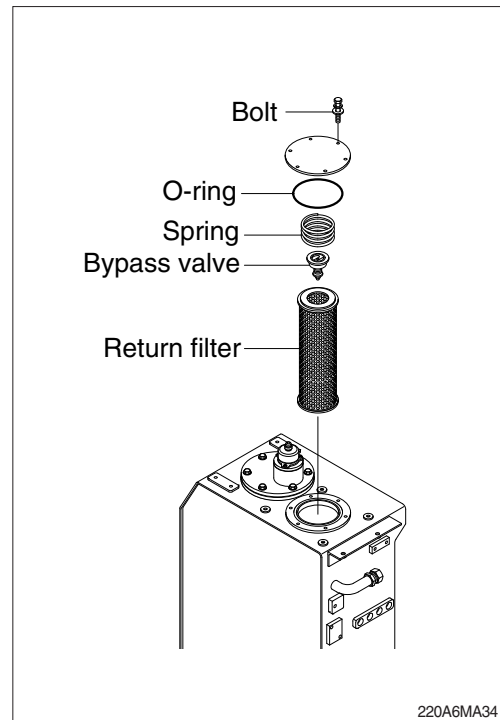

29) REPLACEMENT OF ELEMENT IN HYDRAULIC TANK AIR BREATHER

- (1) Relieve the pressure in the tank by pushing the top of the air breather.
- (2) Loosen the bolt and remove the cover.
- (3) Pull out the air breather element.
- (4) Replace the air breather element with a new one.
- (5) Reassemble by reverse order of disassembly.
 - Tightening torque : $4.05 \pm 0.8 \text{ kgf} \cdot \text{m}$
($29.3 \pm 5.8 \text{ lbf} \cdot \text{ft}$)

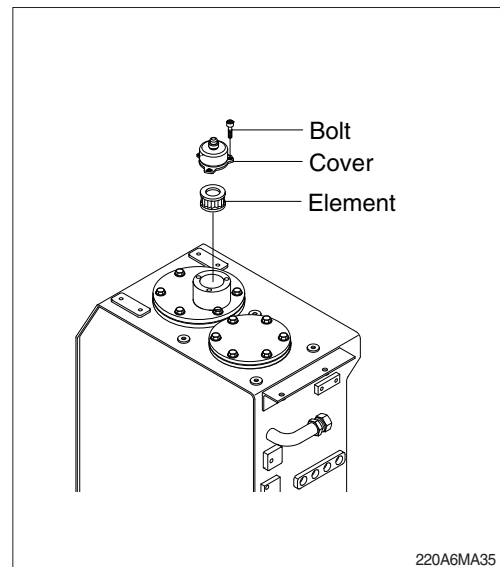

30) REPLACEMENT OF DRAIN FILTER

Clean the dust around filter and replace with new one after removing the drain filter.

- ※ Tighten about 2/3 turn more after the gasket of the drain filter contacts seal side of filter head.
- ※ Change the drain filter after initial 250 hours of operation. Thereafter, change the drain filter every 1000 hours.

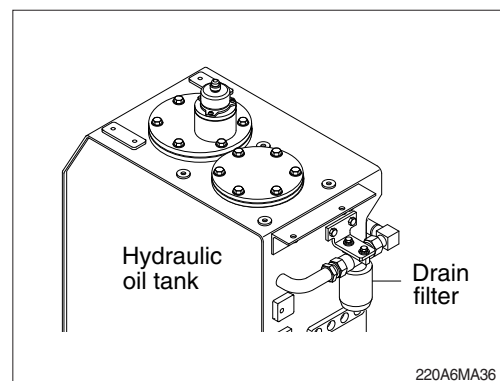

31) REPLACEMENT OF PILOT LINE FILTER ELEMENT

- (1) Loosen the nut positioned on the filter body.
 - (2) Pull out the filter element and clean filter housing.
 - (3) Install the new element and tighten using specified torque.
 - Tightening torque : 2.5 kgf·m (18.1 lbf·ft)
- ※ **Change the element after initial 250 hours of operation. Thereafter, change the element every 1000 hours.**

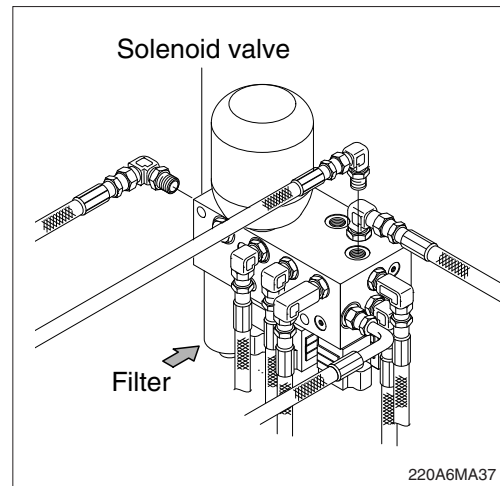

32) CHECK THE SWING REDUCTION GEAR OIL

- (1) Pull out the dipstick and clean it.
- (2) Insert it again.
- (3) Pull out one more time to check the oil level and fill the oil if the level is not sufficient.

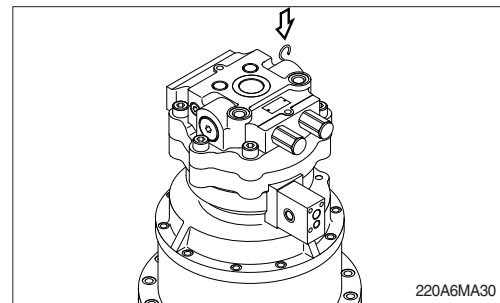

33) CHANGE SWING REDUCTION GEAR OIL

- (1) Raise the temperature of oil by swinging the machine and park the machine on the flat ground.
- (2) Prepare a proper container with a capacity of 10 l (2.6 U.S. gal).
- (3) Open the cap and loosen the drain valve.
- (4) Clean around the valve and close the drain valve and cap.
 - Fill proper amount of recommended oil.
 - Amount of oil : 6.2 l (1.6 U.S. gal)

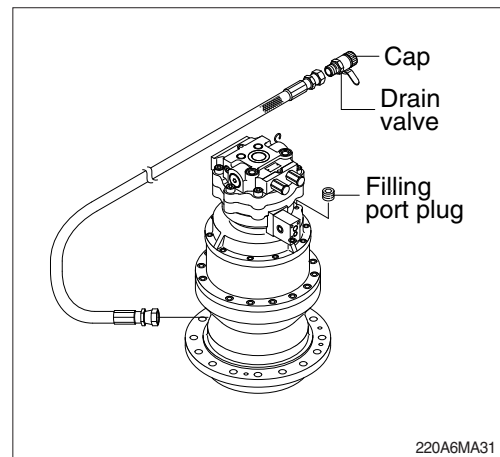

34) LUBRICATE SWING BEARING

- (1) Grease at the 2 fittings shown in the photo.
- ※ **Lubricate every 250 hours.**

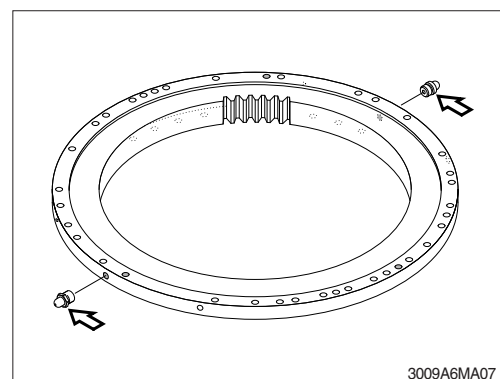

35) SWING GEAR AND PINION

(1) Drain old grease

- ① Remove under cover of lower frame.
- ② Remove drain cover of lower frame.
- ③ Remove filler cover of upper frame.
- ④ Operate full turn (360°) of swing several times.

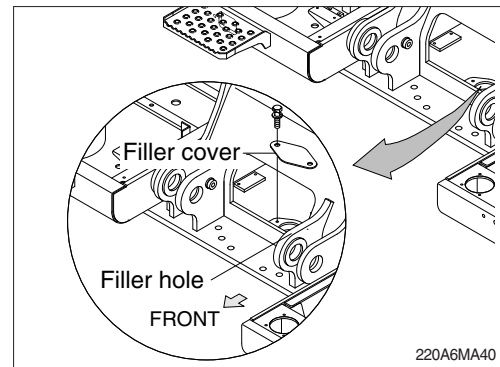

(2) Refill new grease

- ① Install drain cover.
- ② Fill with new grease.
- ③ Install filler cover.
 - Capacity : 8.0 kg (17.6 lb)

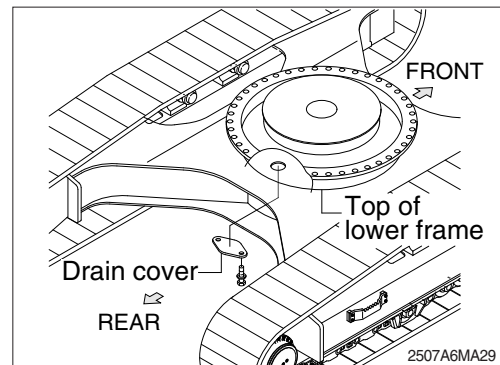

36) CHECK THE TRAVEL REDUCTION GEAR OIL

- (1) Position the travel motor as shown in the illustration and make sure the machine is on flat ground.
- (2) Loosen the level plug and check the oil level. If the level is at the hole of the plug, it is normal. Fill the oil if it is not sufficient.
 - Tightening torque : 10 ± 1.0 kgf·m
(72.3 ± 7.2 lbf·ft)

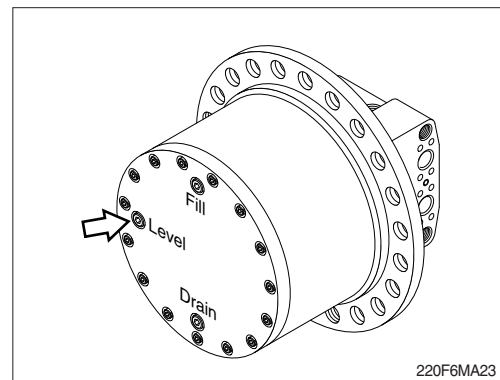

37) CHANGE OF THE TRAVEL REDUCTION GEAR OIL

- (1) Raise the temperature of the oil by operating the machine first.
- (2) Position the travel motor as shown in the illustration and make sure the machine is on flat ground.
- (3) Loosen the level plug, then the drain plug .
- (4) Drain the oil to adequate container with a capacity of 10 ℓ (2.6 U.S. gal).
- (5) Tighten the drain plug and fill specified amount of oil at filling port.
 - Amount of oil : 4.5 ℓ (1.2 U.S. gal)
 - Tightening torque : 10 ± 1.0 kgf·m
(72.3 ± 7.2 lbf·ft)
- (6) Tighten the level plug and travel slowly to check if there is any leakage of oil.

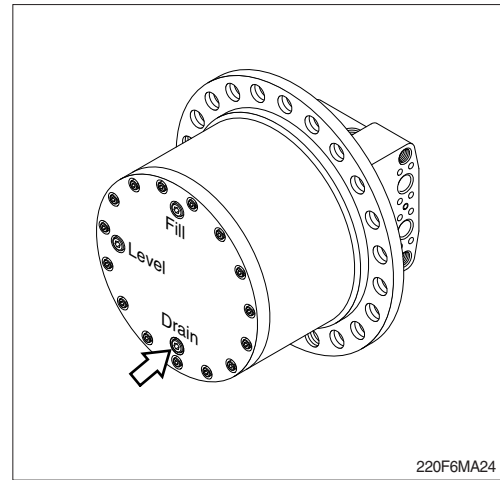

38) LUBRICATE RCV LEVER

Remove the bellows and with a grease gun grease the joint part (A) and sliding parts (B).

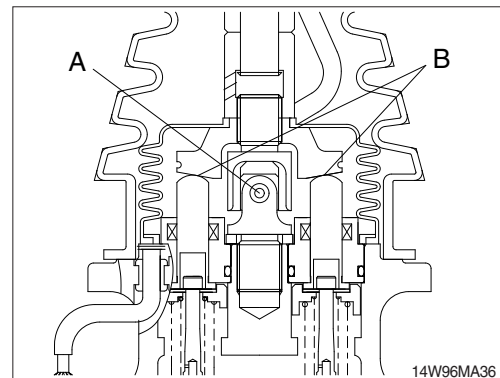

39) ADJUSTMENT OF TRACK TENSION

▲ Serious injury or death can result from grease under pressure. Keep face, hands and body away from the nipple and valve.

※ It is important to adjust the tension of track properly to extend the life of track and traveling components.

※ The wear of pins and bushings on the undercarriage will vary with the working conditions and soil properties.

It is thus necessary to continually inspect the track tension so as to maintain the standard tension on it.

(1) Raise the chassis with the boom and arm as shown in the illustration.

(2) Measure the distance between bottom of track frame on track center and back of shoe.

※ **Remove mud by rotating the track before measuring.**

(3) If the tension is tight, loosen the valve (B) gradually to drain the grease, but not more than one turn.

If the tension is loose, fill the grease through grease nipple (C) using a grease gun.

(4) When the proper track tension is obtained, close grease valve (B) but do not tighten excessively as the fitting may be damaged.

· Valve tightening torque : 13 kgf · m (94 lb · ft)

※ **Remove the mud and sand on the assembly face in order to prevent damage to seal (A) before assembling grease valve (B).**

If seal (A) is damaged, replace with a new one and assemble.

▲ When loosening the grease valve (B), do not loosen more than one turn as there is danger of a spring coming out of the valve (B) because of the high pressure inside.

※ When the grease does not drained smoothly, move the machine to forward and backward a short distance.

If the track tension is loose even after the grease is charged to the maximum, change the pins and bushings as they are worn excessively.

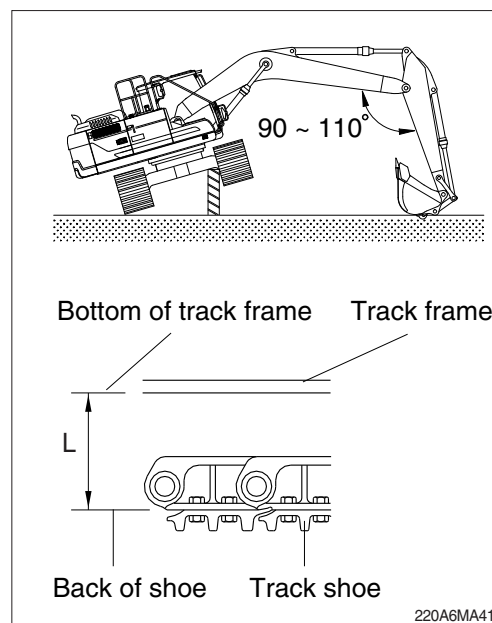

Length (L)	
360~390 mm	14.2~15.4"

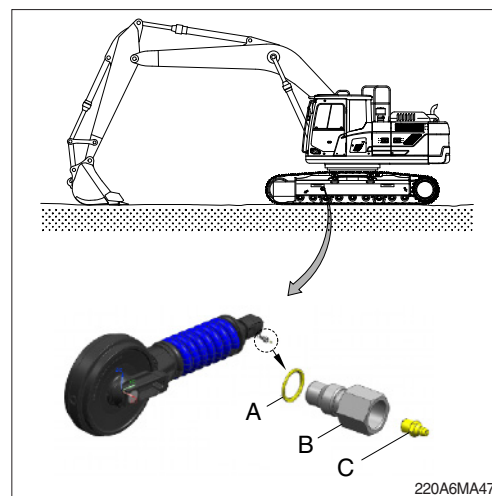

40) REPLACEMENT OF BUCKET

△ When knocking the pin in with a hammer, metal particles may fly and cause serious injury, particularly if they get into your eyes. When carrying out this operation, always wear goggles, helmet, gloves, and other protective equipment.

※ When the bucket is removed, place it in a stable condition.

※ When performing joint work, make sure to signal clearly to each other and work carefully to avoid serious injury.

(1) Lower the bucket on the ground as shown in the illustration on the top right.

(2) Lock the safety knob to the LOCK position and stop the engine.

(3) Remove the stopper bolts (1) and nuts (2), then remove pins (3, 4) and remove the bucket.

※ When removing the pins, place the bucket so that it is in light contact with the ground.

※ If the bucket is lowered strongly to the ground, the resistance will be increased and it will be difficult to remove the pins.

※ After removing the pins, make sure that they do not become contaminated with sand or mud and that the seals of bushings on both sides do not become damaged.

(4) Align the arm with holes (A) and the link with holes (B), then coat with grease and install pins (3, 4)

※ When installing the bucket, the O-rings are easily damaged, so fit the O-rings on the boss of the bucket as shown in the picture.

After hitting the pin, move the O-ring down to the regular groove.

(5) Install the stopper bolt (1) and nuts (2) for each pin, then grease the pin.

- Tightening torque : $29.7 \pm 4.5 \text{ kgf} \cdot \text{m}$
($215 \pm 32.5 \text{ lbf} \cdot \text{ft}$)

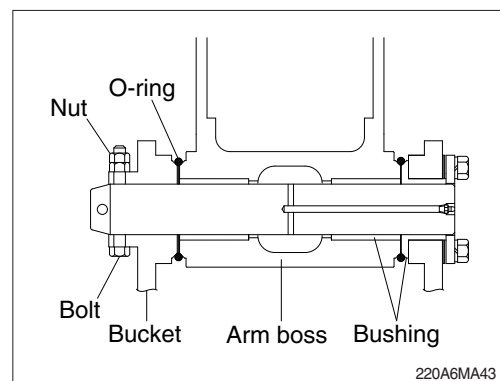
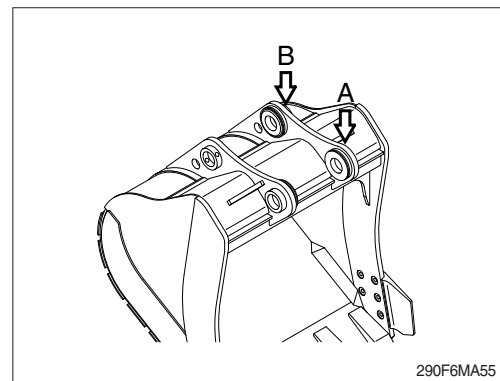
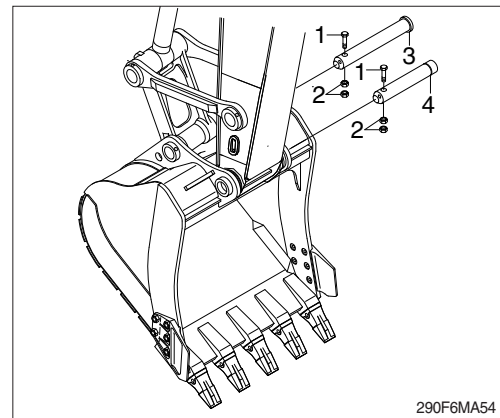
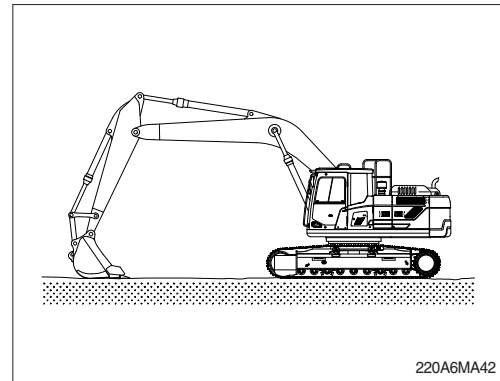

41) REPLACEMENT OF BUCKET TOOTH

(1) Timing of replacement

- ① Check wearing condition as shown in the illustration and replace tooth point before adapter starts to wear.
- ② In case of excessive use and tooth adapter has worn excessively, replacement may become impossible.

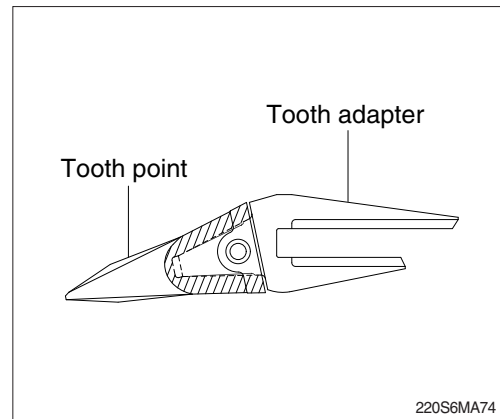

(2) Instructions for replacement

- ① Pull out pin by striking pin with punch or hammer, avoiding damage to lock washer.
- ② Remove dust and mud from surface of tooth adapter by using knife.
- ③ Place lock washer in its proper place, and fit tooth point to adapter.
- ④ Insert pin until lock washer is positioned at tooth pin groove.

▲ Serious injury or death can result from bucket falling.

▲ Block the bucket before changing tooth points or side cutters.

▲ The operator should wear clothes and personal protection gear that are appropriate for the work environment. Protects the eyes from dust, particles and airborne materials with a protection gear like goggle.

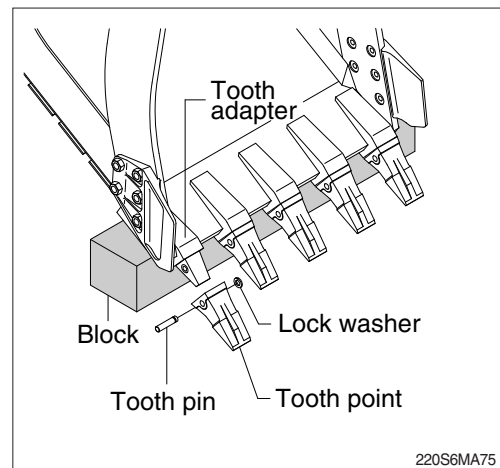

42) ADJUSTMENT OF BUCKET CLEARANCE

- (1) Lower the bucket on the ground as shown in the illustration.
- (2) Swing to the left and keep arm boss in contact with the left bucket ear.
- (3) Lock the safety knob to the LOCK position and stop the engine.
- (4) Measure the clearance (A) between bucket and arm boss. This is the total clearance.

(5) Adjusting

- ① Loosen bolt (2), and remove washer (3), plate (1) and shim (4).
- ② Remove the shim equivalent value with measuring value.
- ③ Assemble the parts in the reverse order of removal.
 - Tightening torque : $29.6 \pm 3.2 \text{ kgf} \cdot \text{m}$
($214.0 \pm 23.1 \text{ lbf} \cdot \text{ft}$)
 - Normal clearance : $0.5 \sim 1.0 \text{ mm}$
($0.02 \sim 0.04 \text{ in}$)

※ If the bucket is not adjusted correctly, noise and vibration will occur. This will also cause damage to O-ring and bushings prematurely.

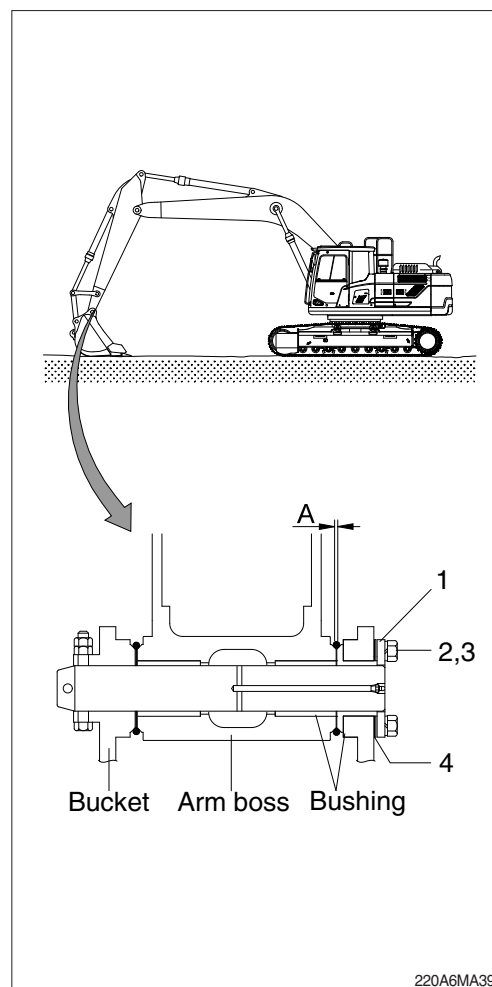

43) LUBRICATE PIN AND BUSHING

(1) Lubricate to each pin of working device

Lubricate the grease to the grease nipple according to the lubricating interval.

No.	Description	Qty
1	Lubrication manifold at boom	5
2	Boom cylinder pin (head)	2
3	Lubricating manifold	3
4	Bucket cylinder pin (head, rod)	2
	Bucket link (control rod)	2
	Arm and bucket connection pin	1
	Arm and control rod connection pin	1
5	Arm and control link connection pin	1
	Boom rear bearing center	1

※ Shorten lubricating interval when working in water or dusty places.

(2) Dust seals are mounted on the rotating part of working device to extend the lubricating interval.

※ Mount the lip so it is facing outside when replacing dust seals.

※ If it is assembled in wrong direction, it will cause fast wear of pin and bushing, and create noise and vibration during operation.

※ Install seal in the same manner as shown in the illustration. Use a plastic hammer to lightly and evenly tap the seal into place.

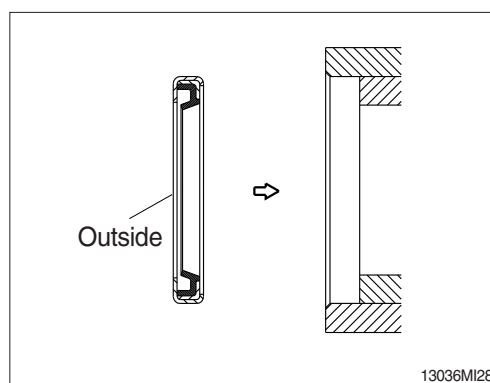
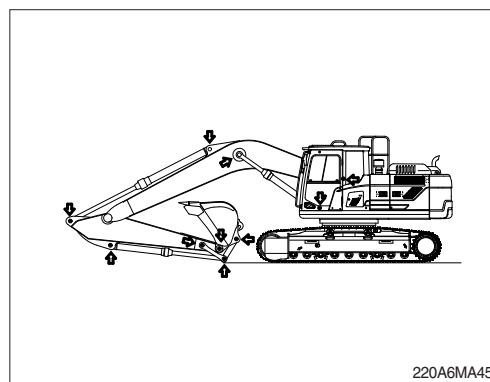
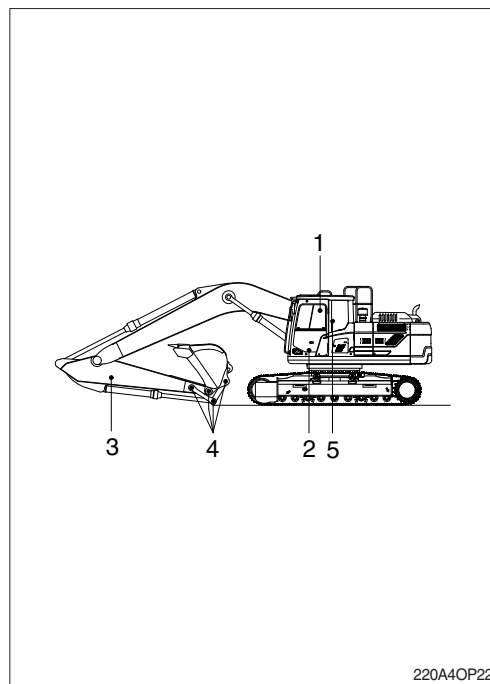

7. ELECTRICAL SYSTEM

1) WIRING, GAUGES

Check regularly and repair loose or malfunctioning gauges when found.

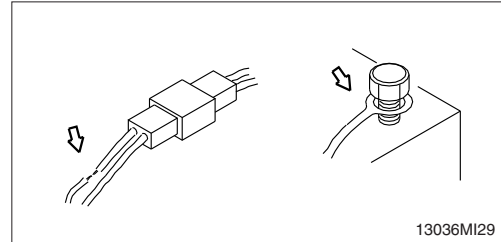

2) BATTERY

(1) Clean

① Wash the terminal with hot water if it is contaminated, and apply grease to the terminals after washing.

⚠ Battery gas can explode. Keep sparks and flames away from batteries.

⚠ Always wear protective glasses when working with batteries.

⚠ Do not stain clothes or skin with electrolyte as it is acid.

Be careful not to get the electrolyte in eyes. If eyes are affected, flush with clean water or eye solution and seek immediate medical attention.

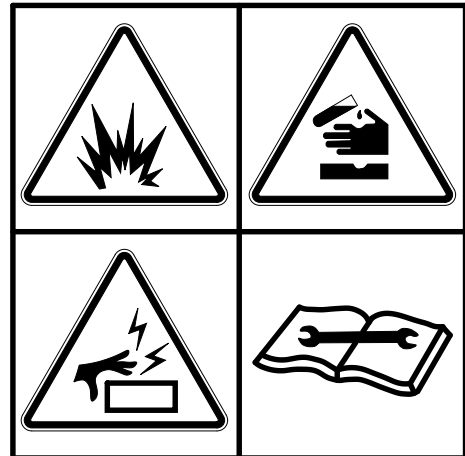

(2) Recycle

Never discard a battery.

Always return used batteries to one of the following locations.

- A battery supplier
- An authorized battery collection facility
- Recycling facility

(3) Method of removing the battery cable

Remove the cable from the ground connection first (⊖ terminal side) and reconnect it last when reassembling.

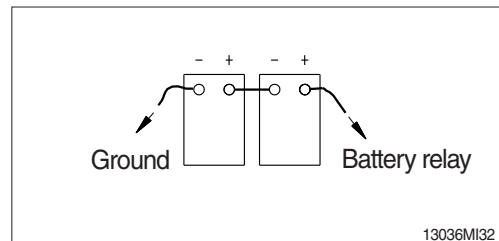

3) STARTING THE ENGINE WITH A BOOSTER CABLE

Follow these procedures when starting.

(1) Connection of booster cable

※ Use the same capacity of battery for starting.

- ① Make sure that the starting switches of the normal machine and trouble machine are both in the OFF position.
- ② Connect the red terminal of booster cable to the battery (+) terminal between exhausted and new battery.
- ③ Connect the black terminal of the booster cable between new battery (-) terminal and chassis of trouble machine.

※ Make and maintain a firm connection.

※ Sparks will occur slightly when making the final connection.

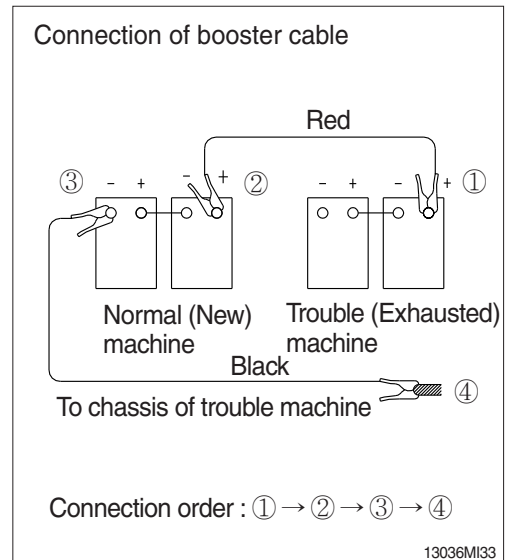

(2) Starting the engine

- ① Start the engine of the normal machine and keep it running at high idle.
- ② Start engine of the troubled machine with starting switch.
- ③ If you can not start it with the first attempt, try again after 2 minutes.

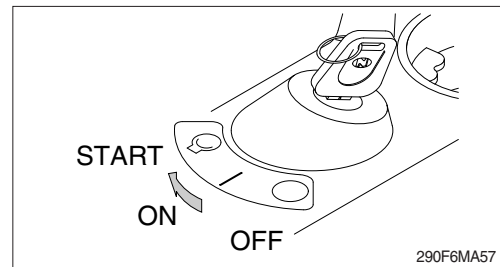

(3) Taking off the booster cable

- ① Take off the booster cable (black).
- ② Take off the booster cable (red) connected to the (+) terminal.
- ③ Run engine at high idle until charging of the exhausted battery is complete.

▲ Explosive gas is generated while using the battery or charging it. Keep any flames away and be careful not to cause a spark.

※ Charge the battery in a well ventilated area.

※ Place the machine on the earth or concrete. Avoid charging the machine on any steel or steel plates.

※ Do not connect (+) terminal and (-) terminal when connecting booster cable because it will be shorted.

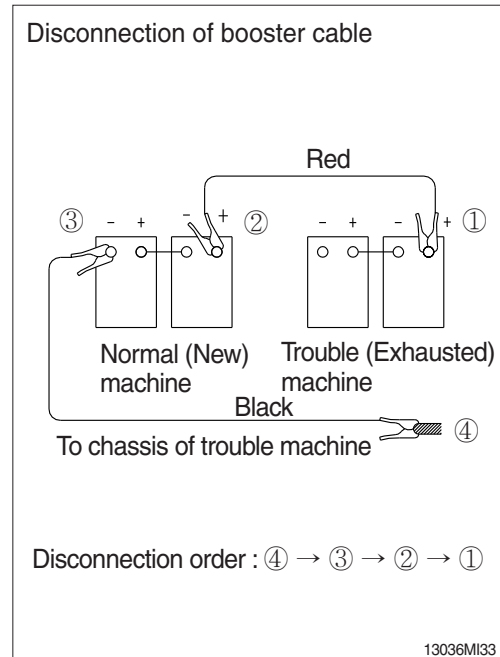

4) WELDING REPAIR

Before welding, follow the below procedure.

- (1) Shut off the engine and remove the key.
 - (2) Disconnect ground cable from battery by master switch.
 - (3) Before carrying out any electric welding on the machine, the battery cables should be disconnected and the connectors pulled out of the electronic control units (MCU, ECM, cluster etc).
 - (4) Connect the earth (ground) lead of the welding equipment as close to the welding point as possible.
- ※ Remove all paint to ensure a solid ground is achieved.
- ※ Do not weld or use cutting torch on pipes or tubes that contain flammable fluids. Clean them thoroughly with nonflammable solvent before welding or cutting on them.
- ▲ Do not attempt to weld before carrying out the above.
If not, it will cause serious damage to electric system.

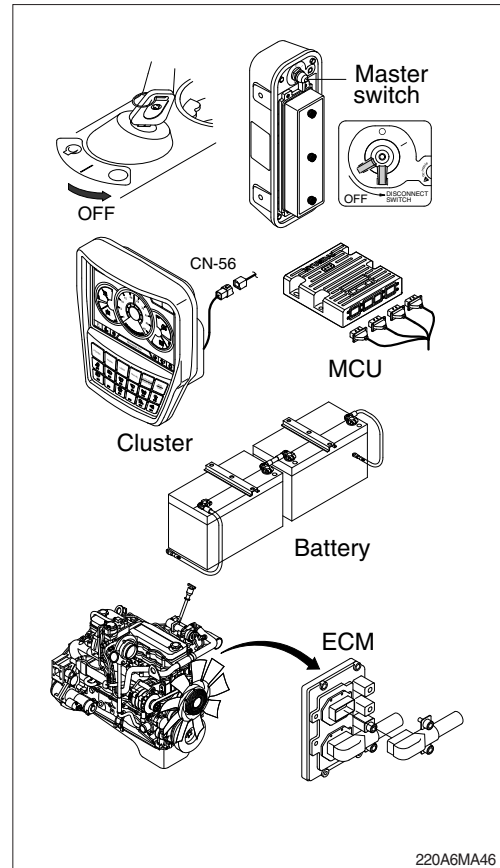

5) BATTERY CABLE AND CONNECTIONS

▲ Batteries can emit explosive gases. To reduce the possibility of personal injury, always ventilate the compartment before servicing the batteries.

- (1) Remove and inspect the battery cables and connections for cracks or corrosion.
- (2) Replace broken terminals, connectors, or cables.
- (3) If the connections are corroded, use a battery brush or wire brush to clean the connections.
- (4) Make sure all debris are removed from the connecting surfaces.
- (5) Install the cables and tighten the battery connections.
- (6) Coat the terminals with grease to prevent corrosion.

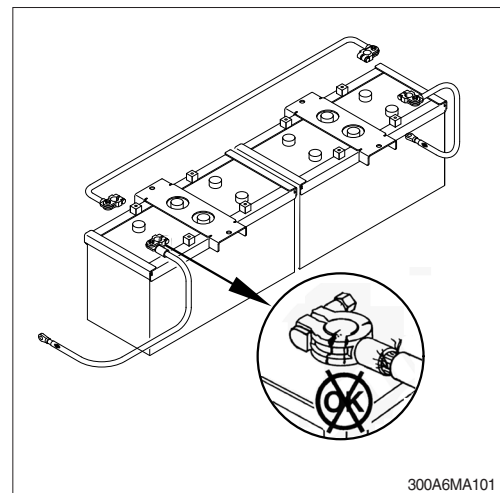

8. AIR CONDITIONER AND HEATER

1) CLEANING AND REPLACEMENT OF OUTER FILTER

※ Always stop the engine before servicing.

(1) Open the outer filter room.

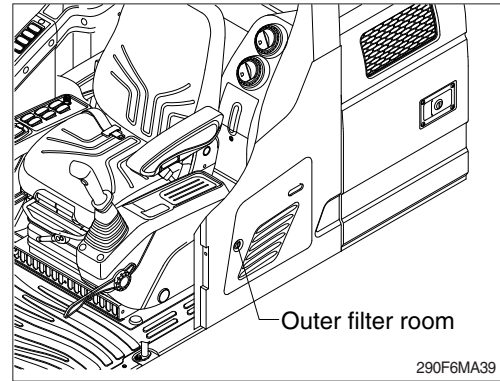

(2) Remove the outer filter.

※ When installing a filter, be careful not to install the filter in the wrong direction.

(3) If the filter is damaged or badly contaminated, use a new filter.

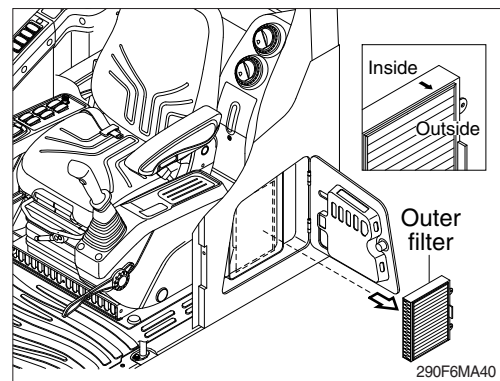

2) CLEANING AND REPLACEMENT OF INNER FILTER

※ Always stop the engine before servicing.

(1) Move seat and console box forward by using the adjust knob.

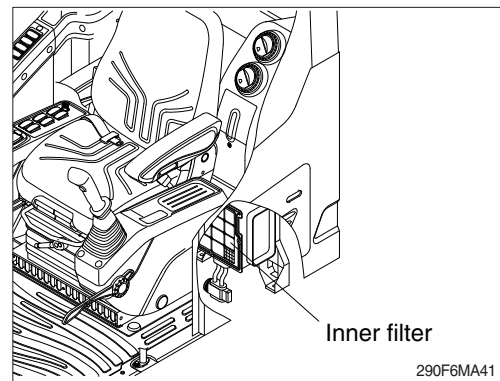

(2) Remove the inner filter.

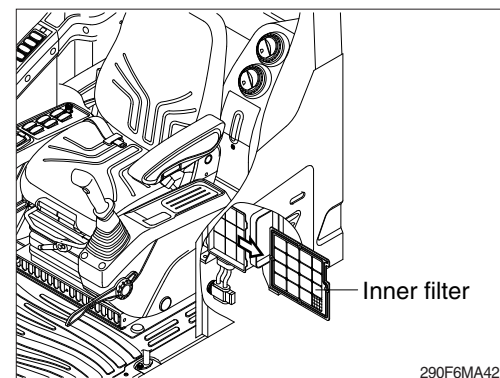

(3) Check the inner filter type.

(4) Non-woven fabric type (if equipped)

- If the filter is damaged or badly contaminated, use a new filter.

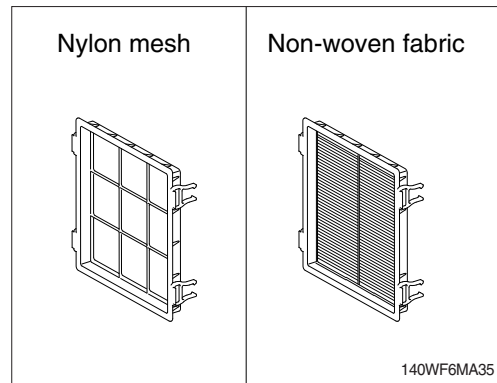

(5) Clean the inner filter using pressurized air (below 2 kgf/cm², 28 psi) or washing with water.

△ **When using pressurized air, be sure to wear safety glasses.**

※ **Dry off after washing with water.**

(6) Inspect the filter after cleaning. If it is damaged or badly contaminated, use a new filter.

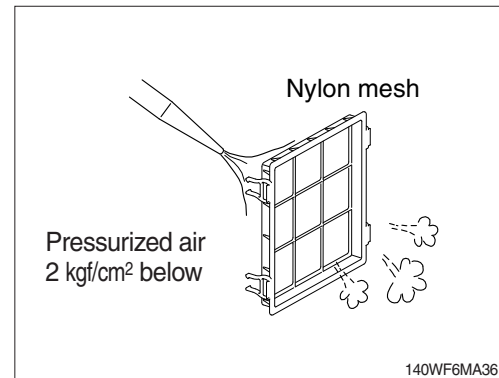

3) PRECAUTIONS FOR USING AIR CONDITIONER

- (1) When using the air conditioner for a long time, open the window once every one hour or ventilate by using the fresh air function.
- (2) Be careful not to overcool the cab.
- (3) The cab is properly cooled if the operator feels cool when entering from outside (about 5°C lower than the outside temperature).

4) CHECK DURING SEASON

Ask the service center for replenishment of refrigerant or other maintenance service so that the cooling performance does not wear prematurely.

5) CHECK DURING OFF-SEASON

Operate the air conditioner 2 or 3 times a month (each time for a few minutes) to avoid loss of oil film in the compressor.

6) REFRIGERANT

(1) Equipment contains fluorinated greenhouse gas.

Model	Type	Quantity	GWP : 1430
HX220A L	HFC-134a	0.75 kg (1.65 lb)	CO ₂ eq. : 1.07t

※ GWP

Global warming potential (GWP) is a measure of how much heat a gas traps in the atmosphere relative to that of carbon dioxide (CO₂). GWP is calculated in terms of the 100-year warming potential of 1 kg of a greenhouse gas relative to 1 kg of CO₂.

(2) Environmental precautions

The air conditioning system of the machine is filled with HFC-134a refrigerant at the factory. HFC-134a refrigerant is a fluorinated greenhouse gas and contributes to global warming. Do not release refrigerant into the environment.

(3) Safety precautions

Work on the air conditioning system must only be performed by a qualified service technician. Do not attempt to perform work on the air conditioning system. Wear safety goggles, chemical resistant gloves and appropriate personal protective equipment to protect bare skin when there is a risk of contact with refrigerant.

(4) Action in case of exposure

- ① Eye contact / Limited skin contact
Rinse with warm water and apply a light bandage. Seek medical attention immediately.
- ② Extensive skin contact
Rinse with warm water and carefully heat the area with warm water or warm clothing. Seek medical attention immediately.
- ③ Inhalation
Leave the area and find fresh air. Seek medical attention immediately.

TRANSPORTATION

1. PREPARATION FOR TRANSPORTATION

- 1) When transporting the machine, observe the various road rules, road transportation vehicle laws and vehicle limit ordinances, etc.
- 2) Select proper trailer after confirming the weight and dimension from the chapter 7, specification.
- 3) Check the whole route such as the road width, the height of bridge and limit of weight etc., which will be passed.
- 4) Get permission from the related authority if necessary.
- 5) Prepare suitable capacity of trailer to support the machine.

- 6) Prepare gangplank for safe loading referring to the below table and illustration.

A	B
1.0	3.65 ~ 3.85
1.1	4.00 ~ 4.25
1.2	4.35 ~ 4.60
1.3	4.75 ~ 5.00
1.4	5.10 ~ 5.40
1.5	5.50 ~ 5.75

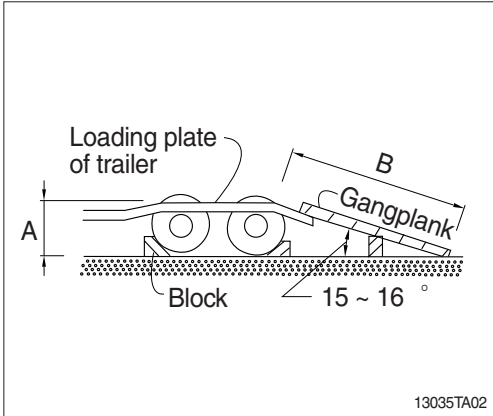
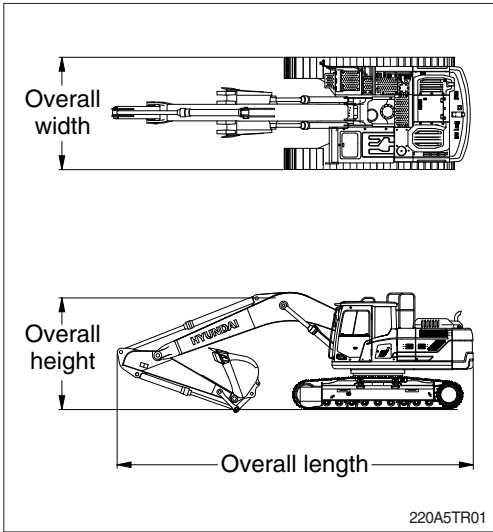

2. DIMENSION AND WEIGHT

1) HX220A L

(1) Base machine

Mark	Description	Unit	Specification
L	Length	mm (ft-in)	4990 (16' 4")
H	Height	mm (ft-in)	3000 (9' 10")
W	Width	mm (ft-in)	2990 (9' 10")
Wt	Weight	kg (lb)	18406 (40580)

※ With 600 mm (24") triple grouser shoes and 3800 kg (8380 lb) counterweight.

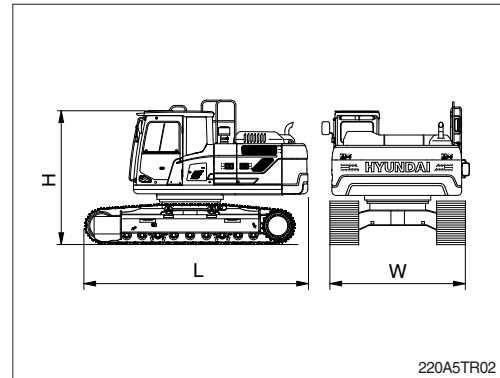

(2) Boom assembly

Mark	Description	Unit	Specification
L	Length	mm (ft-in)	5900 (19' 4")
H	Height	mm (ft-in)	1550 (5' 1")
W	Width	mm (ft-in)	700 (2' 4")
Wt	Weight	kg (lb)	1950 (4300)

※ 5.68 m (18' 8") boom with arm cylinder (including piping and pins).

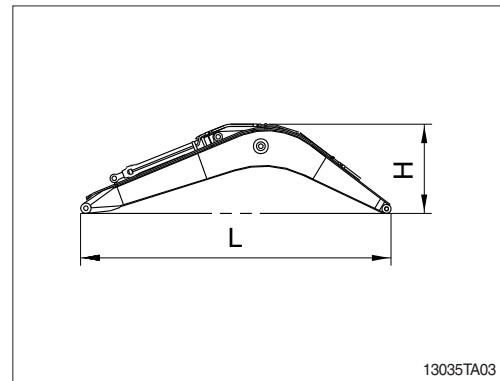

(3) Arm assembly

Mark	Description	Unit	Specification
L	Length	mm (ft-in)	3910 (12'10")
H	Height	mm (ft-in)	870 (2' 10")
W	Width	mm (ft-in)	350 (1' 2")
Wt	Weight	kg (lb)	1095 (2410)

※ 2.92 m (9' 7") arm with bucket cylinder (including linkage and pins).

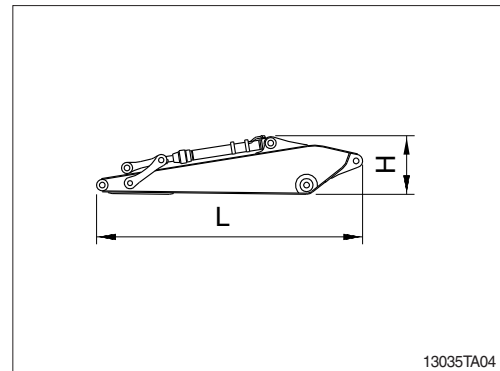

(4) Bucket assembly

Mark	Description	Unit	Specification
L	Length	mm (ft-in)	1600 (5' 3")
H	Height	mm (ft-in)	980 (3' 3")
W	Width	mm (ft-in)	1280 (4' 2")
Wt	Weight	kg (lb)	820 (1810)

※ 0.92 m³ (1.20 yd³) SAE heaped bucket (including tooth and side cutters).

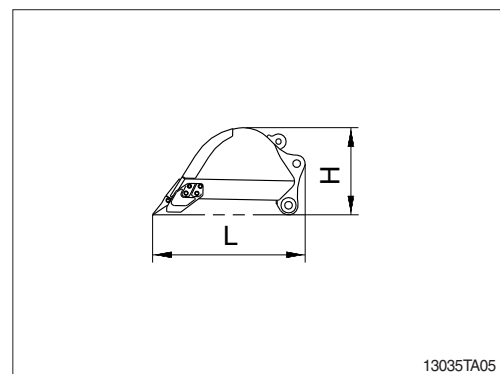

(5) Boom cylinder

Mark	Description	Unit	Specification
L	Length	mm (ft-in)	1960 (6' 5")
H	Height	mm (ft-in)	211 (0' 8")
W	Width	mm (ft-in)	303 (1' 0")
Wt	Weight	kg (lb)	180 (400)

※ Including piping.

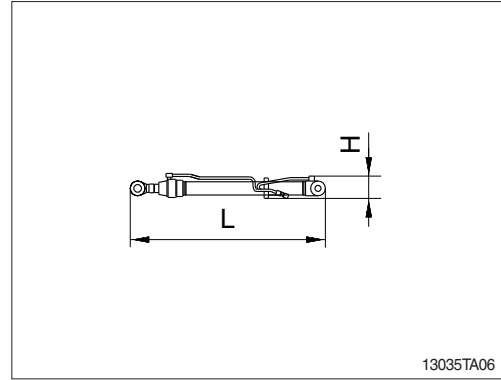

(6) Cab assembly

Mark	Description	Unit	Specification
L	Length	mm (ft-in)	1962 (6' 6") [2070 (6' 10")]
H	Height	mm (ft-in)	1693 (5' 7") [1822 (6')]
W	Width	mm (ft-in)	1000 (3' 4") [1126 (3' 8")]
Wt	Weight	kg (lb)	490 (1080) [641.7 (1415)]

[] : with FOG GUARD

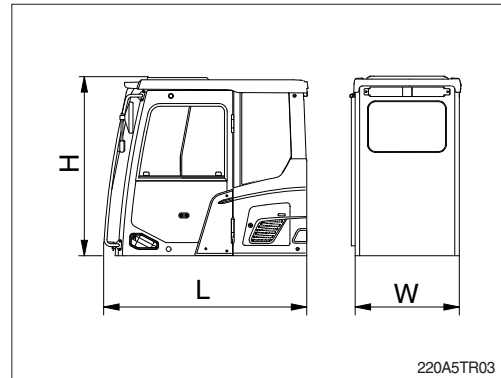

(7) Counterweight

Mark	Description	Unit	Specification
L	Length	mm (ft-in)	2740 (9' 0")
H	Height	mm (ft-in)	1255 (4' 2")
W	Width	mm (ft-in)	560 (1' 10")
Wt	Weight	kg (lb)	5300 (11680)

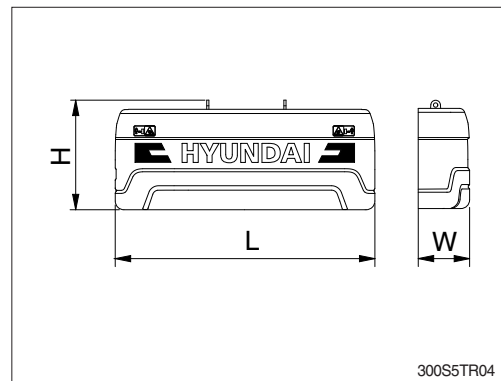

2) HX220 L LR

(1) Base machine

Mark	Description	Unit	Specification
L	Length	mm (ft-in)	4995 (16' 4")
H	Height	mm (ft-in)	3000 (9' 10")
W	Width	mm (ft-in)	3190 (10' 6")
Wt	Weight	kg (lb)	20668 (45570)

※ With 800 mm (32") triple grouser shoes and 5300 kg (11680 lb) counterweight.

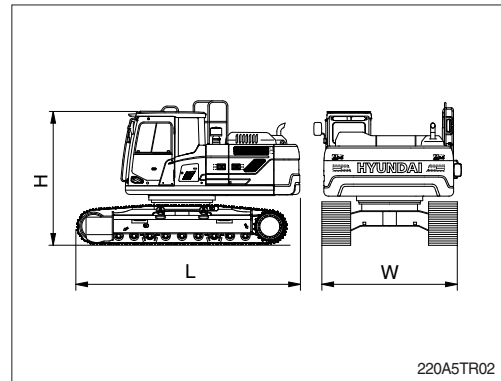

(2) Boom assembly

Mark	Description	Unit	Specification
L	Length	mm (ft-in)	8395 (27' 7")
H	Height	mm (ft-in)	1515 (5' 0")
W	Width	mm (ft-in)	800 (2' 7")
Wt	Weight	kg (lb)	2470 (5450)

※ 8.2 m (26' 11") boom with arm cylinder (including piping and pins).

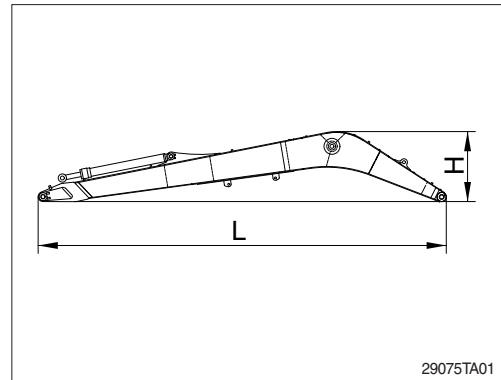

(3) Arm assembly

Mark	Description	Unit	Specification
L	Length	mm (ft-in)	7280 (23' 11")
H	Height	mm (ft-in)	835 (2' 9")
W	Width	mm (ft-in)	480 (1' 7")
Wt	Weight	kg (lb)	1340 (2950)

※ 6.3 m (20' 8") arm with bucket cylinder (including linkage and pins).

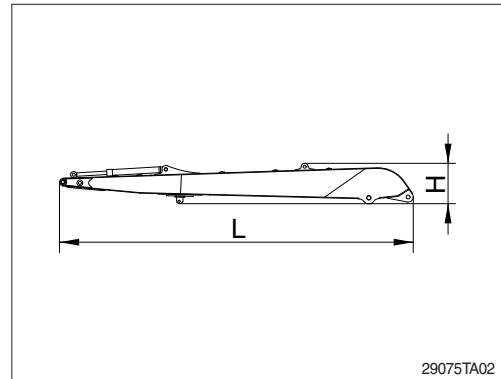

(4) Bucket assembly

Mark	Description	Unit	Specification
L	Length	mm (ft-in)	1400 (4' 7")
H	Height	mm (ft-in)	820 (2' 8")
W	Width	mm (ft-in)	1020 (3' 4")
Wt	Weight	kg (lb)	460 (1010)

※ 0.52 m³ (0.68 yd³) SAE heaped bucket (including tooth and side cutters).

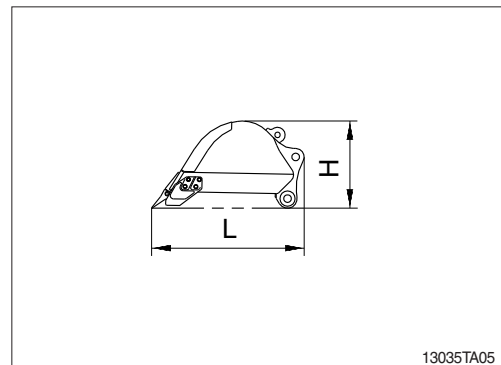

(5) Boom cylinder

Mark	Description	Unit	Specification
L	Length	mm (ft-in)	1960 (6' 5")
H	Height	mm (ft-in)	211 (0' 8")
W	Width	mm (ft-in)	303 (1' 0")
Wt	Weight	kg (lb)	180 (400)

※ Including piping.

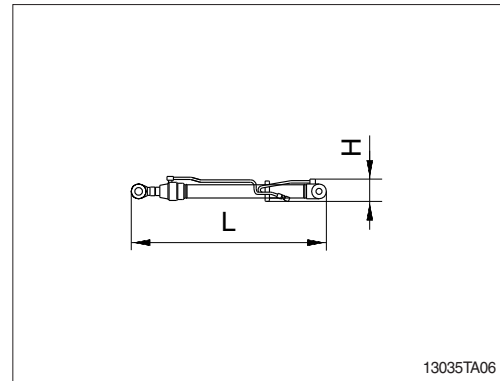

(6) Cab assembly

Mark	Description	Unit	Specification
L	Length	mm (ft-in)	1962 (6' 6") [2070 (6' 10")]
H	Height	mm (ft-in)	1693 (5' 7") [1822 (6')]
W	Width	mm (ft-in)	1000 (3' 4") [1126 (3' 8")]
Wt	Weight	kg (lb)	490 (1080) [641.7 (1415)]

[] : with FOG GUARD

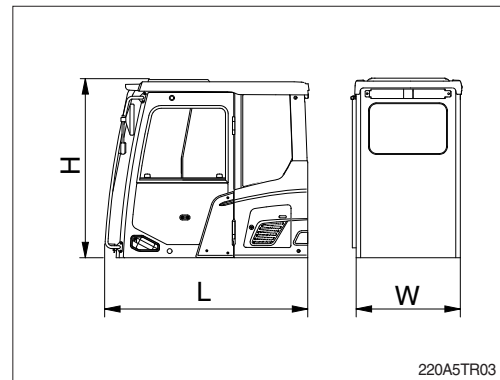

(7) Counterweight

Mark	Description	Unit	Specification
L	Length	mm (ft-in)	2740 (9' 0")
H	Height	mm (ft-in)	1255 (4' 2")
W	Width	mm (ft-in)	560 (1' 10")
Wt	Weight	kg (lb)	5300 (11680)

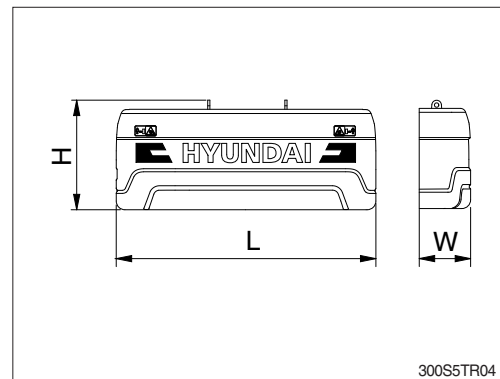

3) HX220A HW

(1) Base machine

Mark	Description	Unit	Specification
L	Length	mm (ft-in)	4990 (16' 4")
H	Height	mm (ft-in)	3200 (10' 6")
W	Width	mm (ft-in)	3395 (11' 2")
Wt	Weight	kg (lb)	20545 (45290)

※ With 600 mm (24") triple grouser shoes and 3800 kg (8380 lb) counterweight.

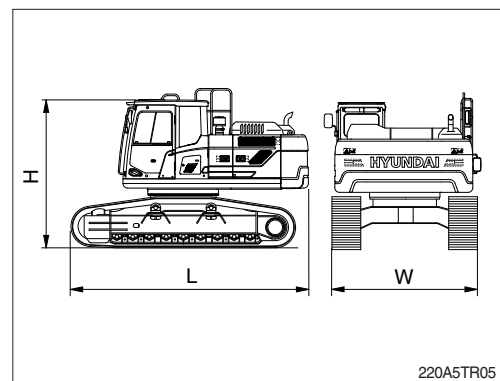

3. LOADING THE MACHINE

- 1) Load and unload the machine on flat ground.
- 2) Use the gangplank with sufficient length, width, thickness and gradient.
- 3) Place the swing lock/fine switch to the LOCK position (if equipped) before fixing the machine at the bed of trailer and confirm if the machine is parallel the bed of trailer.
Keep the travel motor in the rear when loading and in the front when unloading.

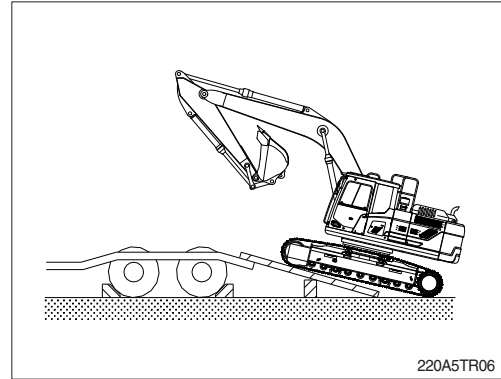

- 4) Do the following after loading the machine to the trailer.
 - (1) Stop loading when the machine is located horizontally with the rear wheel of trailer.

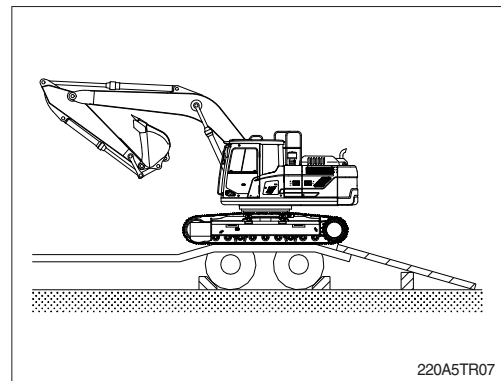

- (2) Place the swing lock/fine switch to the LOCK position (if equipped) after the swinging the machine 180°.

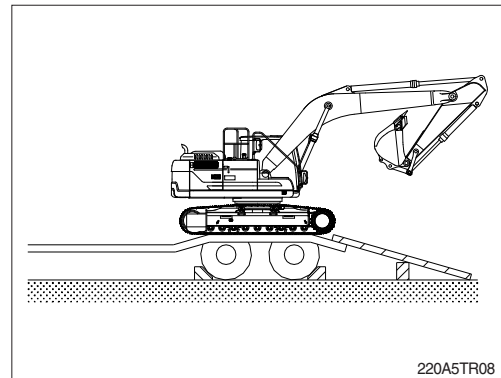

- (3) Lower the working equipment gently after the location is determined.
- ※ Place rectangular timber under the bucket cylinder to prevent the damage of it during transportation.
 - ▲ Be sure to keep the travel speed switch on the LOW (turtle mark) while loading and unloading the machine.
 - ▲ Avoid using the working equipment for loading and unloading as it will be very dangerous.
 - ▲ Do not operate any other device when loading.
 - ▲ Be careful as to the boundaries of loading plate or trailer as the balance of machine will abruptly be change.

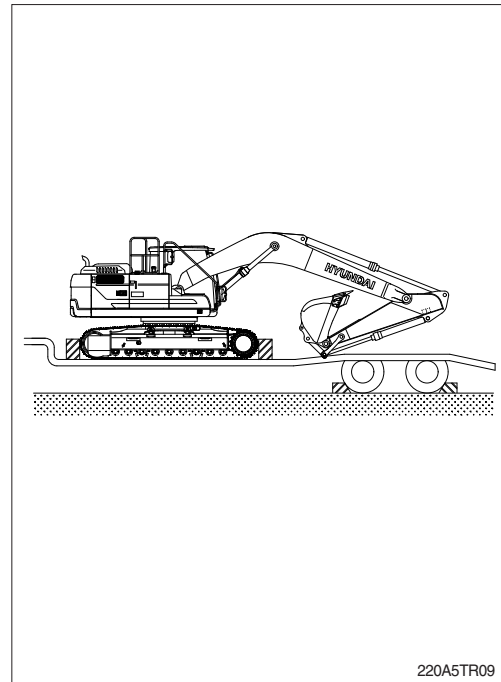

4. FIXING THE MACHINE

- 1) Lower down the working device on the loading plate of trailer.
- 2) Keep the safety knob in the LOCK position.
- 3) Turn OFF all the switches and remove the key.

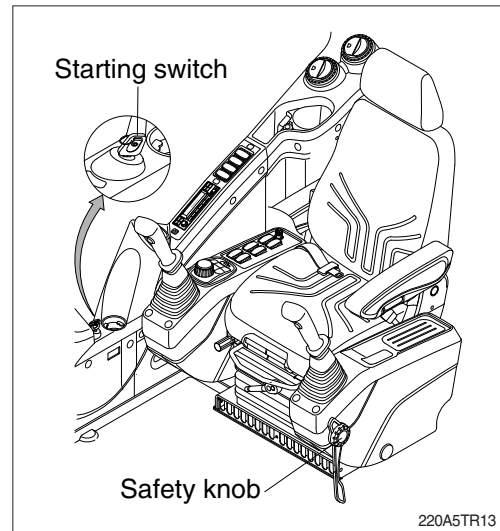

- 4) Secure all locks.

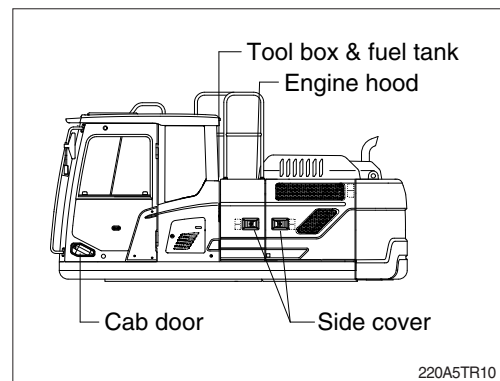

- 5) Place timbers behind the tracks, secure the machine to trailer with chains or straps which are in good condition and approved for the weight which they will be securing, to prevent the machine from moving in any direction.

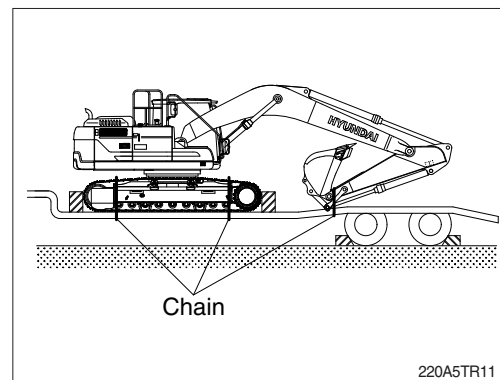

5. LOADING AND UNLOADING BY CRANE

▲ The wrong hoisting method or installation of lifting device can cause serious injury, death, or damage to the machine.

- 1) Check the weight, length, width and height of the machine referring to chapter 7, Specification when you are going to hoist the machine.
- 2) Use approved lifting device and ensure distance between lifting device and machine to avoid contact between the two.
- 3) Place rubber plates at lifting points to avoid any damage to the machine.
- 4) Place crane in the proper place.
- 5) Install approved lifting device as shown in the illustration.

▲ Ensure that lifting device is free from any damage and is approved for the weight being lifted and supported.

▲ Place the safety knob to LOCK position to prevent the machine from moving when hoisting the machine.

▲ Do not load abruptly.

▲ Keep area clear of any and all personnel.

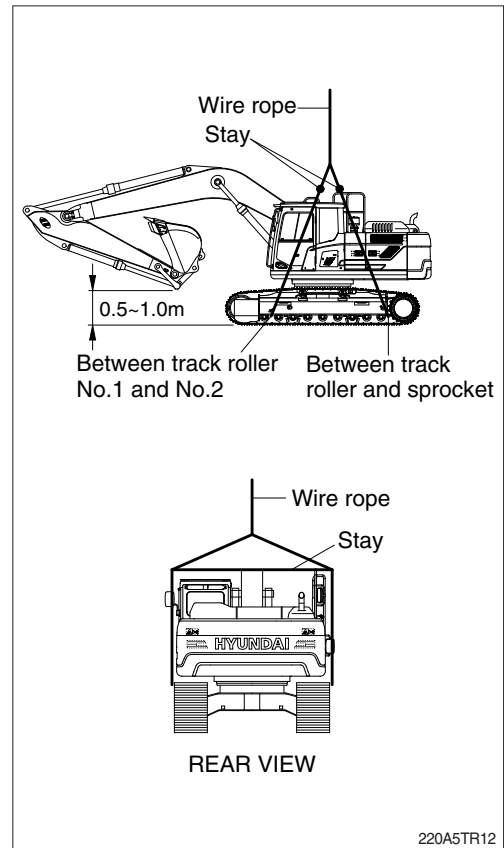

TROUBLESHOOTING GUIDE

1. ENGINE

※ This guide is not intended to cover every condition, however many of the more common possibilities are listed.

Trouble	Service	Remark
The engine oil pressure lamp lights up when engine speed is raised after completion of warm up.	<ul style="list-style-type: none"> · Add the oil to the specified level. · Replace the oil filter cartridge. · Check oil leakage from the pipe or the joint. · Replace the monitor. 	
Steam is emitted from the top part of the radiator (the pressure valve). Coolant level warning lamp lights up.	<ul style="list-style-type: none"> · Supply coolant and check leakage. · Adjust fan belt tension. · Wash out inside of cooling system. · Clean or repair the radiator fin. · Check the thermostat. · Tighten the radiator cap firmly or replace the cap itself. · Replace the monitor. 	
The engine does not start when the starting motor is turned over.	<ul style="list-style-type: none"> · Confirm fuel supply. · Repair where air is leaking into fuel system. · Check the injection pump or the nozzle. · Check the valve clearance. · Check engine compression. · In cold weather, check if fuel warmer system is working normal. 	Refer to the pages 2-4 and 3-41.
Exhaust gas is white or blue.	<ul style="list-style-type: none"> · Adjust to specified oil quantity. · Replace with specified fuel. 	
Exhaust gas occasionally turns black.	<ul style="list-style-type: none"> · Clean or replace the air cleaner element. · Check the nozzle. · Check engine compression. · Clean or replace the turbocharger. 	
Combustion noise occasionally changes to breathing sound.	<ul style="list-style-type: none"> · Check the nozzle. 	
Unusual combustion noise or mechanical noise.	<ul style="list-style-type: none"> · Confirm fuel quality. · Check over-heating · Replace the muffler. · Adjust valve clearance. 	

2. ELECTRICAL SYSTEM

Trouble	Service	Remark
Work lamp does not glow brightly or flickers even when engine runs at high idle.	<ul style="list-style-type: none"> · Check for loose terminals and open-circuit wiring. · Adjust belt tension. 	
Battery charging lamp does not go out even when engine runs at high speed.	<ul style="list-style-type: none"> · Check the alternator. · Check and repair wiring. 	
Unusual noise is emitted from the alternator.	<ul style="list-style-type: none"> · Check the alternator. 	
Starting motor does not turn when starting switch is turned ON.	<ul style="list-style-type: none"> · Check and repair the wiring. · Charge the battery. · Check the starting motor. · Check the safety relay. 	
The pinion of the starting motor keeps going in and out.	<ul style="list-style-type: none"> · Charge the battery. · Check the safety relay. 	
Starting motor turns the engine sluggishly.	<ul style="list-style-type: none"> · Charge the battery. · Check the starting motor. 	
The starting motor disengages before the engine starts up.	<ul style="list-style-type: none"> · Check and repair the wiring. · Charge the battery. 	
The engine warming up lamp does not go ON.	<ul style="list-style-type: none"> · Check and repair wiring. · Check the monitor. 	
The engine oil pressure lamp does not light up when engine is stationary (when the starting switch is in ON position.)	<ul style="list-style-type: none"> · Check the monitor. · Check the caution lamp switch. 	
Battery charging lamp does not light up when the engine is stationary. (when the starting switch is in ON position.)	<ul style="list-style-type: none"> · Check the monitor. · Check and repair the wiring. 	

3. OTHERS

Trouble	Service	Remark
Track slips out of place. Excessive wear of the sprocket.	<ul style="list-style-type: none">· Adjust tension of track.	
Bucket either rises slowly or not at all.	<ul style="list-style-type: none">· Add oil to specified level.	
Slow speed of travel, swing, boom, arm and bucket.	<ul style="list-style-type: none">· Add oil to specified level.	
Unusual noise emitted from pump.	<ul style="list-style-type: none">· Clean the hydraulic tank strainer.	
Excessive oil temperature rise of hydraulic oil.	<ul style="list-style-type: none">· Clean and check the oil cooler.· Adjust fan belt tension.· Add oil to specified level.	

SPECIFICATIONS

1. MAJOR COMPONENT

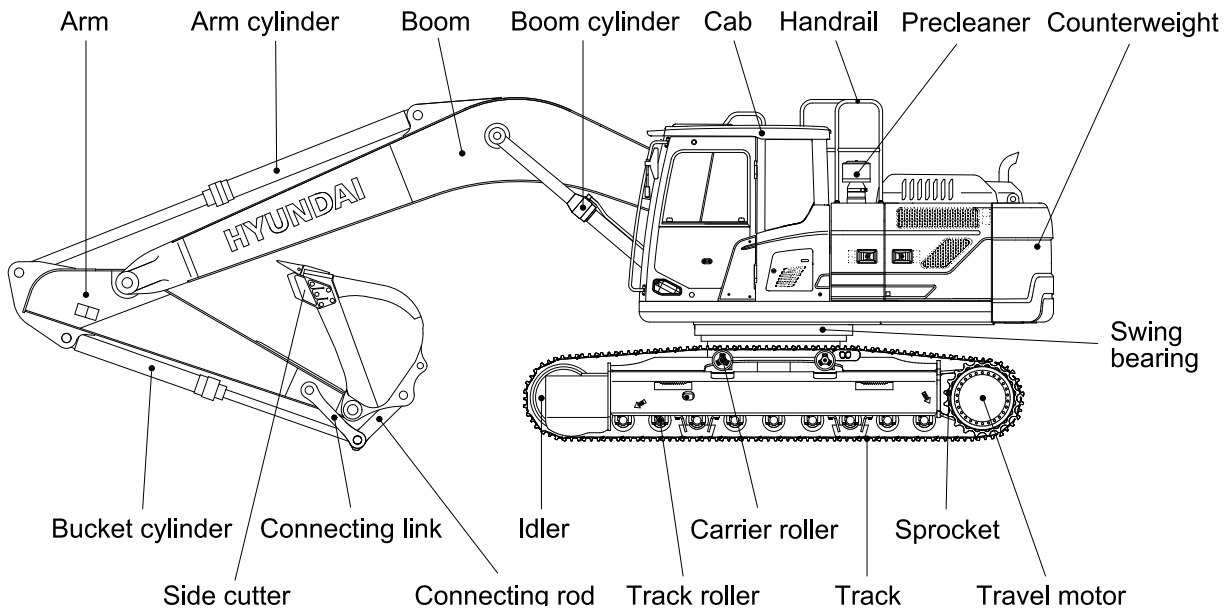
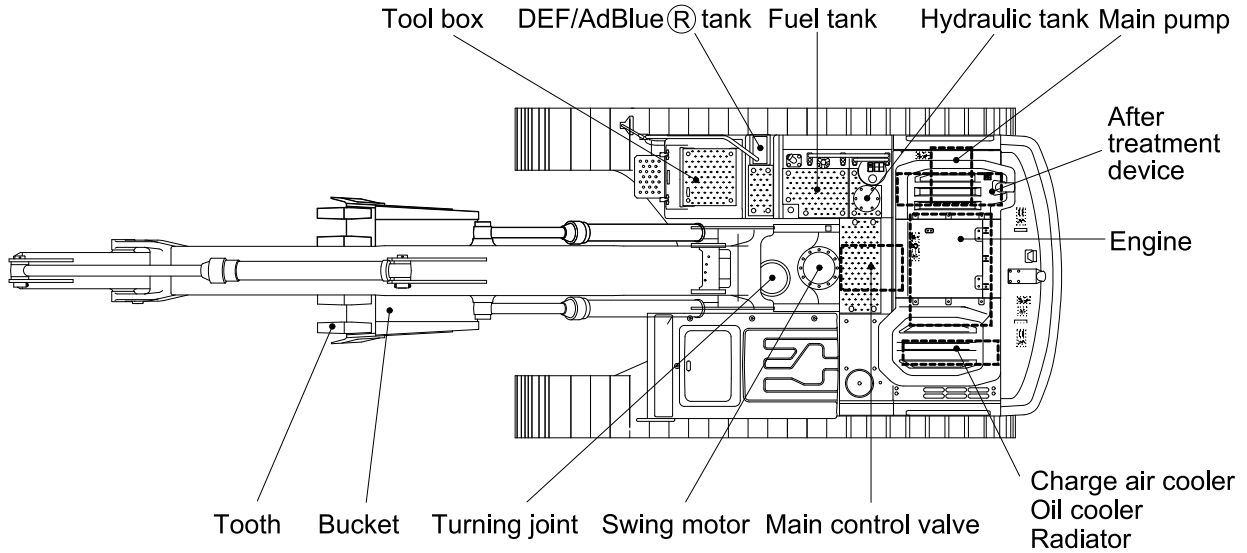

220A2SP01

2. SPECIFICATIONS

1) HX220A L, MONO BOOM

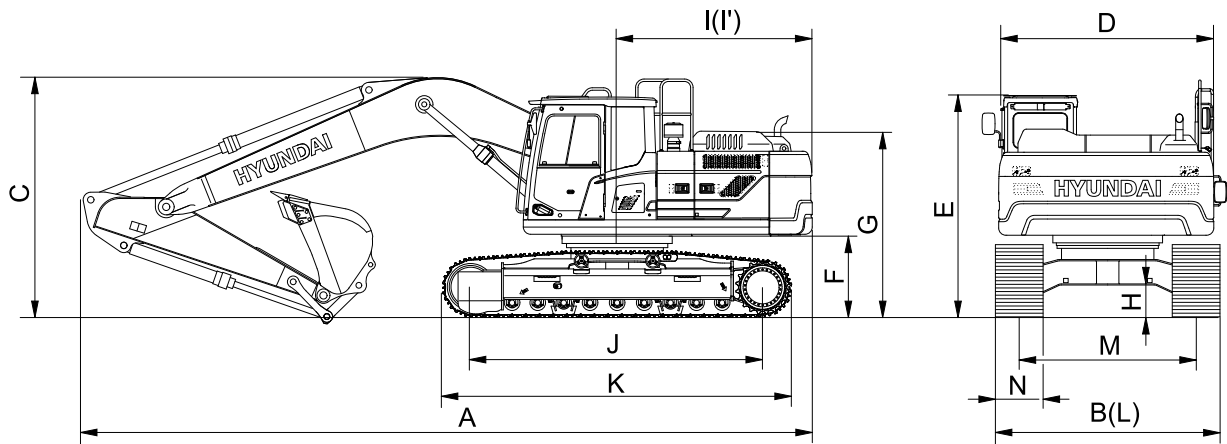

220A2SP02

Description	Unit		Specification			
	m (ft-in)	Boom	5.68 (18' 8")			
		Arm	2.92 (9' 7")	2.00 (6' 7")	2.40 (7' 10")	3.90 (12' 10")
mm (in)	Shoe	600 (24)				
Operating weight	kg (lb)	22280 (49120)	22130 (48790)	22190 (48920)	22510 (49630)	
Bucket capacity (SAE heaped), standard	m ³ (yd ³)	0.92 (1.2)	0.92 (1.2)	0.92 (1.2)	0.92 (1.2)	
Overall length	A	9530 (31' 3")	9650 (31' 8")	9570 (31' 5")	9520 (31' 3")	
Overall width	B	2990 (9' 10")	2990 (9' 10")	2990 (9' 10")	2990 (9' 10")	
Overall height of boom	C	3030 (9' 11")	3200 (10' 6")	3110 (10' 2")	3480 (11' 5")	
Superstructure width	D	2740 (9' 0")	2740 (9' 0")	2740 (9' 0")	2740 (9' 0")	
Overall height of cab	E	3000 (9' 10")	3000 (9' 10")	3000 (9' 10")	3000 (9' 10")	
Ground clearance of counterweight	F	1060 (3' 6")	1060 (3' 6")	1060 (3' 6")	1060 (3' 6")	
Overall height of engine hood	G	2520 (8' 3")	2520 (8' 3")	2520 (8' 3")	2520 (8' 3")	
Overall height of handrail	G'	3210 (10' 6")	3210 (10' 6")	3210 (10' 6")	3210 (10' 6")	
Minimum ground clearance	H	470 (1' 7")	470 (1' 7")	470 (1' 7")	470 (1' 7")	
Rear-end distance	I	2770 (9' 1")	2770 (9' 1")	2770 (9' 1")	2770 (9' 1")	
Rear-end swing radius	I'	2890 (9' 6")	2890 (9' 6")	2890 (9' 6")	2890 (9' 6")	
Distance between tumblers	J	3650 (12' 0")	3650 (12' 0")	3650 (12' 0")	3650 (12' 0")	
Undercarriage length	K	4404 (14' 5")	4404 (14' 5")	4404 (14' 5")	4404 (14' 5")	
Undercarriage width	L	2990 (9' 10")	2990 (9' 10")	2990 (9' 10")	2990 (9' 10")	
Track gauge	M	2390 (7' 10")	2390 (7' 10")	2390 (7' 10")	2390 (7' 10")	
Track shoe width, standard	N	600 (24")	600 (24")	600 (24")	600 (24")	
Travel speed (low/high)	km/hr (mph)	3.5/5.4 (2.2/3.4)	3.5/5.4 (2.2/3.4)	3.5/5.4 (2.2/3.4)	3.5/5.4 (2.2/3.4)	
Swing speed	rpm	11.4	11.4	11.4	11.4	
Gradeability	Degree (%)	35 (70)	35 (70)	35 (70)	35 (70)	
Ground pressure	kgf/cm ² (psi)	0.48 (6.76)	0.47 (6.72)	0.47 (6.74)	0.48 (6.83)	
Max traction force	kg (lb)	20830 (45922)	20830 (45922)	20830 (45922)	20830 (45922)	

2) HX220A L, 2-PIECE BOOM

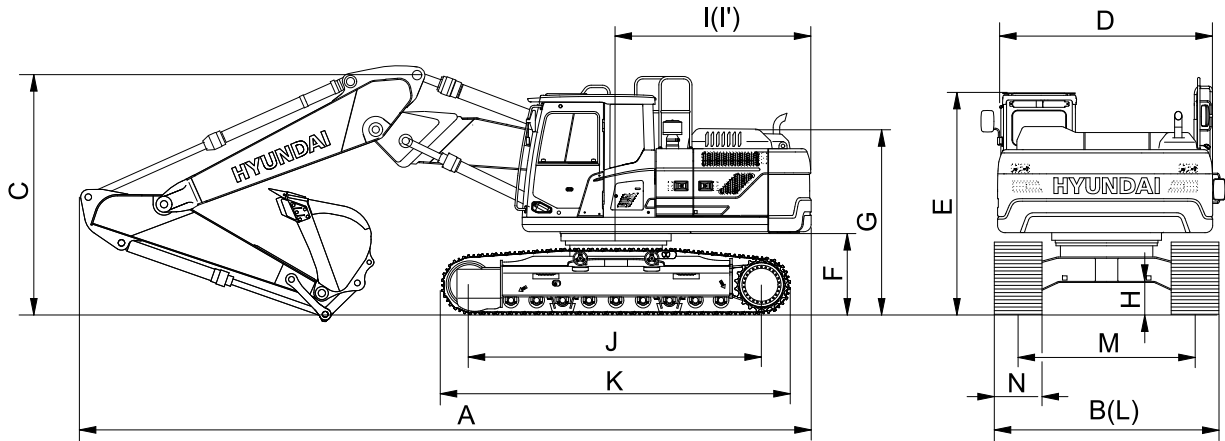

220A2SP08

Description		Unit		Specification
		m (ft-in)	Boom	5.65 (18' 7")
			Arm	2.92 (9' 7")
		mm (in)	Shoe	600 (24)
Operating weight		kg (lb)		22990 (50680)
Bucket capacity (SAE heaped), standard		m ³ (yd ³)		0.92 (1.2)
Overall length	A	mm (ft-in)		9530 (31' 3")
Overall width	B			2990 (9' 10")
Overall height of boom	C			3030 (9' 11")
Superstructure width	D			2740 (9' 0")
Overall height of cab	E			3000 (9' 10")
Ground clearance of counterweight	F			1060 (3' 6")
Overall height of engine hood	G			2520 (8' 3")
Overall height of handrail	G'			3210 (10' 6")
Minimum ground clearance	H			470 (1' 7")
Rear-end distance	I			2770 (9' 1")
Rear-end swing radius	I'			2890 (9' 6")
Distance between tumblers	J			3650 (12' 0")
Undercarriage length	K			4404 (14' 5")
Undercarriage width	L			2990 (9' 10")
Track gauge	M			2390 (7' 10")
Track shoe width, standard	N			600 (24")
Travel speed (low/high)				km/hr (mph)
Swing speed		rpm		11.2
Gradeability		Degree (%)		35 (70)
Ground pressure		kgf/cm ² (psi)		0.49 (6.98)
Max traction force		kg (lb)		20830 (45922)

3) HX220A LR

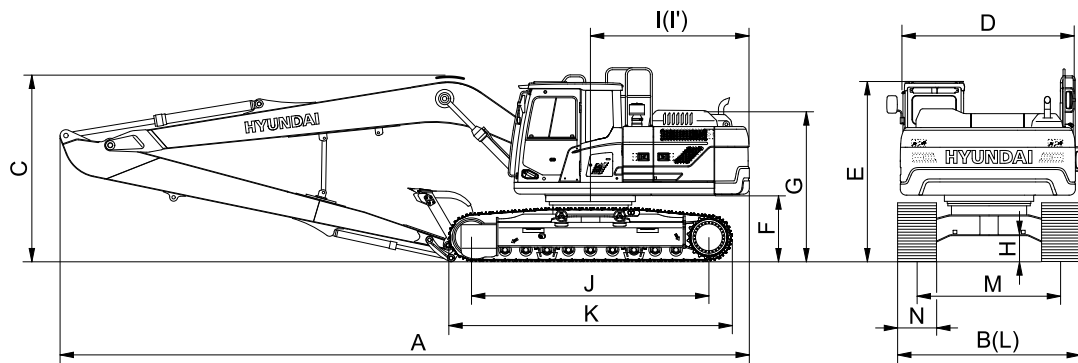

220A2SP03

Description		Unit		Specification
		m (ft-in)	Boom	8.2 (26' 11")
			Arm	6.30 (20' 8")
		mm (in)	Shoe	800 (32)
Operating weight		kg (lb)		25420 (56040)
Bucket capacity (SAE heaped), standard		m ³ (yd ³)		0.92 (1.2)
Overall length	A	mm (ft-in)		12030 (39' 6")
Overall width	B			3190 (10' 6")
Overall height of boom	C			3280 (10' 9")
Superstructure width	D			2740 (9' 0")
Overall height of cab	E			3000 (9' 10")
Ground clearance of counterweight	F			1060 (3' 6")
Overall height of engine hood	G			2520 (8' 3")
Overall height of handrail	G'			3210 (10' 6")
Minimum ground clearance	H			470 (1' 7")
Rear-end distance	I			2770 (9' 1")
Rear-end swing radius	I'			2890 (9' 6")
Distance between tumblers	J			3650 (12' 0")
Undercarriage length	K			4404 (14' 5")
Undercarriage width	L			3190 (10' 6")
Track gauge	M			2390 (7' 10")
Track shoe width, standard	N			800 (32")
Travel speed (low/high)				km/hr (mph)
Swing speed		rpm		11.4
Gradeability		Degree (%)		35 (70)
Ground pressure		kgf/cm ² (psi)		0.41 (5.79)
Max traction force		kg (lb)		20830 (45922)

4) HX220A HW, MONO BOOM

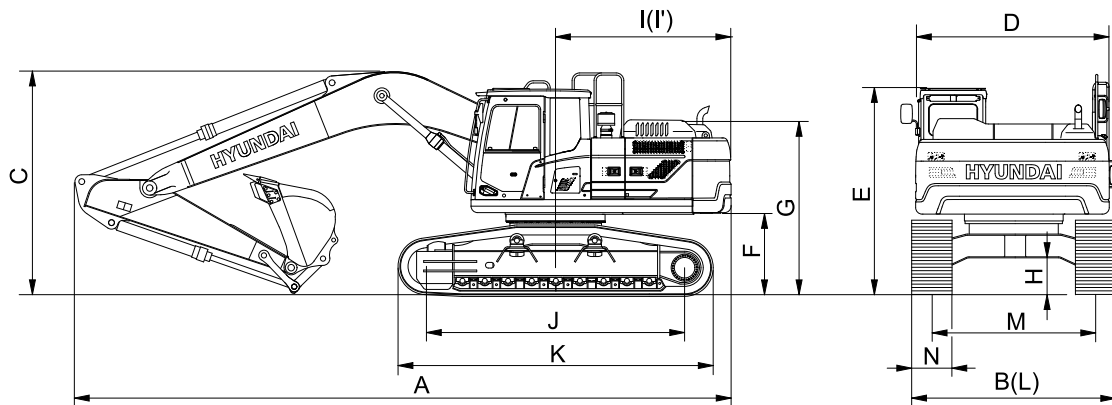

220A2SP04

Description	Unit		Specification			
	m (ft-in)	Boom	5.68 (20' 6")			
		Arm	2.92 (9' 7")	2.00 (6' 7")	2.40 (7' 10")	3.90 (12' 10")
	mm (in)	Shoe	600 (24)			
Operating weight	kg (lb)		23570 (51960)	23410 (51610)	23480 (51760)	23800 (52470)
Bucket capacity (SAE heaped), standard	m ³ (yd ³)		0.92 (1.2)	0.92 (1.2)	0.92 (1.2)	0.92 (1.2)
Overall length	A	mm (ft-in)	9470 (31' 1")	9650 (31' 8")	9550 (31' 4")	9560 (31' 4")
Overall width	B		3395 (11' 2")	3395 (11' 2")	3395 (11' 2")	3395 (11' 2")
Overall height of boom	C		3060 (10' 0")	3290 (10' 10")	3170 (10' 5")	3450 (11' 4")
Superstructure width	D		2740 (9' 0")	2740 (9' 0")	2740 (9' 0")	2740 (9' 0")
Overall height of cab	E		3200 (10' 6")	3200 (10' 6")	3200 (10' 6")	3200 (10' 6")
Ground clearance of counterweight	F		1260 (4' 2")	1260 (4' 2")	1260 (4' 2")	1260 (4' 2")
Overall height of engine hood	G		2720 (8' 11")	2720 (8' 11")	2720 (8' 11")	2720 (8' 11")
Overall height of handrail	G'		3410 (11' 2")	3410 (11' 2")	3410 (11' 2")	3410 (11' 2")
Minimum ground clearance	H		660 (2' 2")	660 (2' 2")	660 (2' 2")	660 (2' 2")
Rear-end distance	I		2770 (9' 1")	2770 (9' 1")	2770 (9' 1")	2770 (9' 1")
Rear-end swing radius	I'		2890 (9' 6")	2890 (9' 6")	2890 (9' 6")	2890 (9' 6")
Distance between tumblers	J		3650 (12' 0")	3650 (12' 0")	3650 (12' 0")	3650 (12' 0")
Undercarriage length	K		4404 (14' 5")	4404 (14' 5")	4404 (14' 5")	4404 (14' 5")
Undercarriage width	L		3395 (11' 2")	3395 (11' 2")	3395 (11' 2")	3395 (11' 2")
Track gauge	M		2795 (9' 2")	2795 (9' 2")	2795 (9' 2")	2795 (9' 2")
Track shoe width, standard	N		600 (24")	600 (24")	600 (24")	600 (24")
Travel speed (low/high)	km/hr (mph)		2.9 (5.1)	2.9 (5.1)	2.9 (5.1)	2.9 (5.1)
Swing speed	rpm		11.4	11.4	11.4	11.4
Gradeability	Degree (%)		35 (70)	35 (70)	35 (70)	35 (70)
Ground pressure	kgf/cm ² (psi)		0.50 (7.15)	0.50 (7.11)	0.50 (7.13)	0.51 (7.22)
Max traction force	kg (lb)		22190 (48921)	22190 (48921)	22190 (48921)	22190 (48921)

3. WORKING RANGE AND DIGGING FORCE

1) HX220A L, MONO BOOM

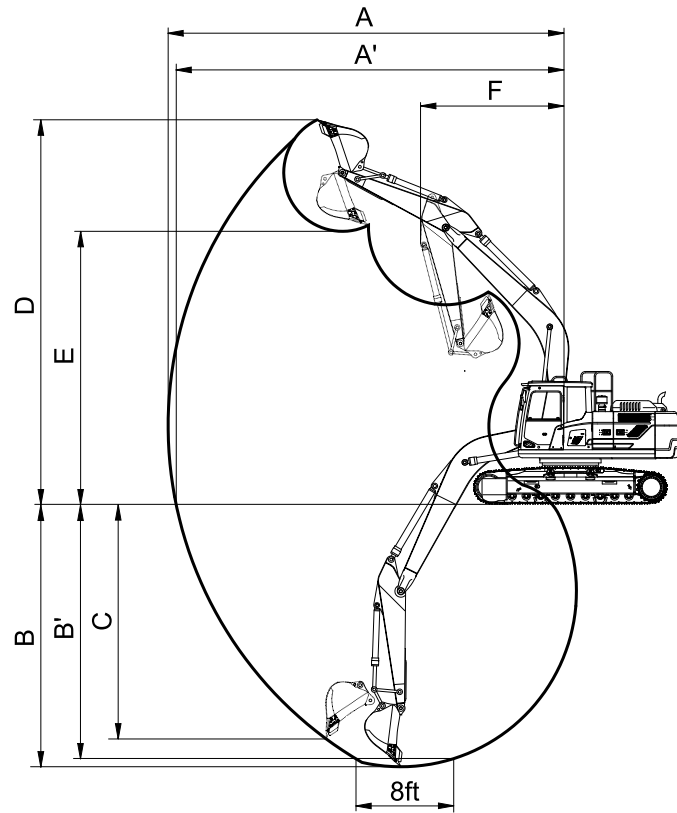

220A2SP05

Description	m (ft-in)	Boom	5.68 (18' 8")			
		Arm	2.92 (9' 7")	2.00 (6' 7")	2.40 (7' 10")	3.90 (12' 10")
Max digging reach	mm (ft-in)	A	9980 (32' 9")	9140 (30' 0")	9500 (31' 2")	10910 (35' 10")
Max digging reach on ground		A'	9820 (32' 3")	8960 (29' 5")	9330 (30' 7")	10770 (35' 4")
Max digging depth		B	6730 (22' 1")	5820 (19' 1")	6220 (20' 5")	7720 (25' 4")
Max digging depth (8 ft level)		B'	6560 (21' 6")	5580 (18' 4")	6010 (19' 9")	7580 (24' 10")
Max vertical wall digging depth		C	6280 (20' 7")	5280 (17' 4")	5720 (18' 9")	7240 (23' 9")
Max digging height		D	9600 (31' 6")	9140 (30' 0")	9340 (30' 8")	10110 (33' 2")
Max dumping height		E	6780 (22' 3")	6330 (20' 9")	6520 (21' 5")	7290 (23' 11")
Min swing radius		F	3670 (12' 0")	3750 (12' 4")	3740 (12' 3")	3700 (12' 2")
Bucket digging force	kN	SAE	133.4 [144.8]	133.4 [144.8]	133.4 [144.8]	133.4 [144.8]
	kgf		13600 [14770]	13600 [14770]	13600 [14770]	13600 [14770]
	lbf		29980 [32560]	29980 [32560]	29980 [32560]	29980 [32560]
	kN	ISO	152.0 [165.0]	152.0 [165.0]	152.0 [165.0]	152.0 [165.0]
	kgf		15500 [16830]	15500 [16830]	15500 [16830]	15500 [16830]
	lbf		34170 [37100]	34170 [37100]	34170 [37100]	34170 [37100]
Arm digging force	kN	SAE	102.0 [110.7]	144.2 [156.5]	119.6 [129.9]	84.3 [91.6]
	kgf		10400 [11290]	14700 [15960]	12200 [13250]	8600 [9340]
	lbf		22930 [24890]	32410 [35190]	26900 [29210]	18960 [20590]
	kN	ISO	106.9 [116.0]	151.0 [164.0]	106.9 [116.0]	87.3 [94.7]
	kgf		10900 [11830]	15400 [16720]	10900 [11830]	8900 [9660]
	lbf		24030 [26080]	33950 [36860]	24030 [26080]	19620 [21300]

[] : Power boost

2) HX220A L, 2-PIECE BOOM

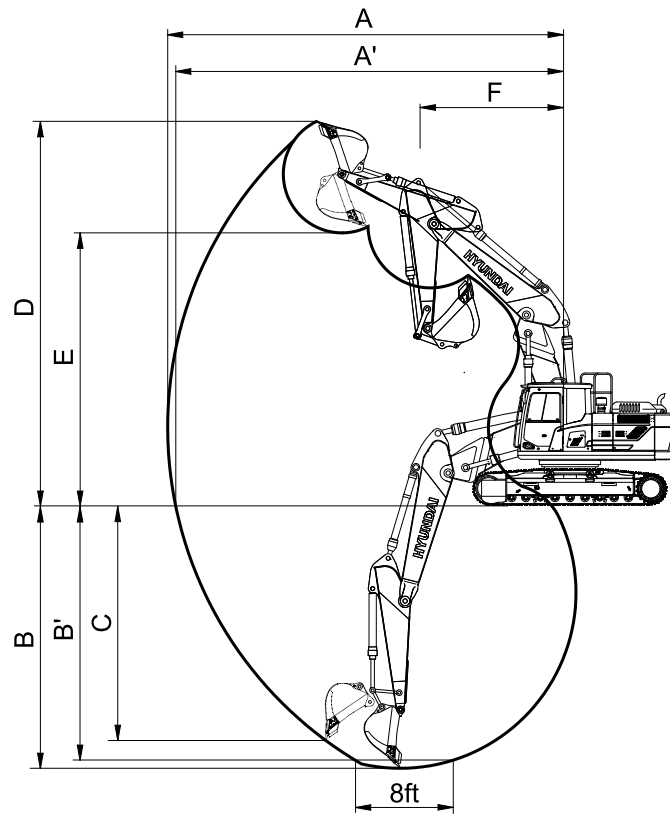

220A2SP10

Description	m (ft-in)	Boom	5.65 (18' 7")
		Arm	2.92 (9' 7")
Max digging reach	mm (ft-in)	A	10020 (32' 10")
Max digging reach on ground		A'	9860 (32' 4")
Max digging depth		B	6400 (21' 0")
Max digging depth (8 ft level)		B'	6290 (20' 8")
Max vertical wall digging depth		C	5560 (18' 3")
Max digging height		D	11090 (36' 5")
Max dumping height		E	8160 (26' 9")
Min swing radius		F	2530 (8' 4")
Bucket digging force	kN	SAE	133.4 [144.8]
	kgf		13600 [14770]
	lbf		29980 [32560]
	kN	ISO	152.0 [165.0]
	kgf		15500 [16830]
	lbf		34170 [37100]
Arm digging force	kN	SAE	102.0 [110.7]
	kgf		10400 [11290]
	lbf		22930 [24890]
	kN	ISO	106.9 [116.0]
	kgf		10900 [11830]
	lbf		24030 [26080]

[] : Power boost

3) HX220A LR

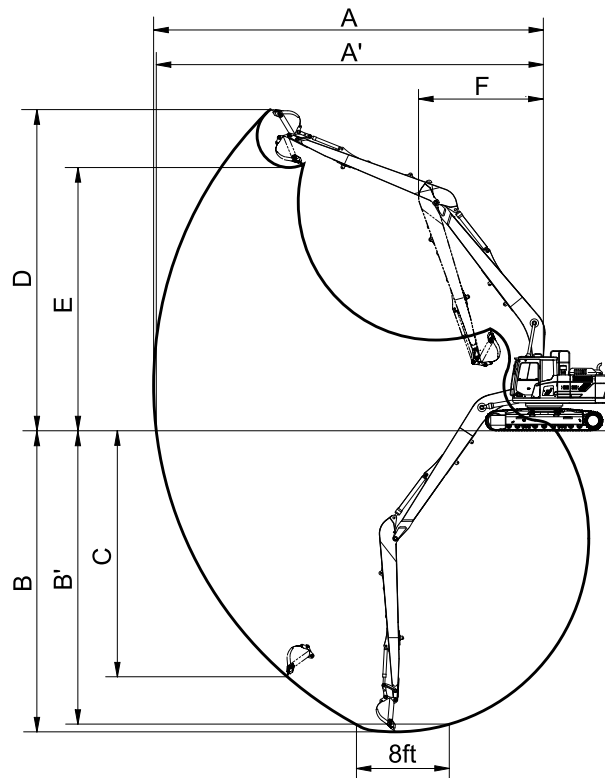

220A2SP06

Description	m (ft-in)	Boom	8.2 (26' 11")
		Arm	6.30 (20' 8")
Max digging reach	mm (ft-in)	A	15220 (49' 11")
Max digging reach on ground		A'	15120 (49' 7")
Max digging depth		B	11760 (38' 7")
Max digging depth (8 ft level)		B'	11650 (38' 3")
Max vertical wall digging depth		C	9610 (31' 6")
Max digging height		D	12550 (41' 2")
Max dumping height		E	10280 (33' 9")
Min swing radius		F	4870 (16' 0")
Bucket digging force	kN	SAE	72.7 [72.7]
	kgf		7410 [7410]
	lbf		16340 [16340]
	kN	ISO	85.0 [85.0]
	kgf		8670 [8670]
	lbf		19110 [19110]
Arm digging force	kN	SAE	48.9 [48.9]
	kgf		4990 [4990]
	lbf		11000 [11000]
	kN	ISO	49.9 [49.9]
	kgf		5090 [5090]
	lbf		11220 [11220]

[] : Power boost

4) HX220A HW

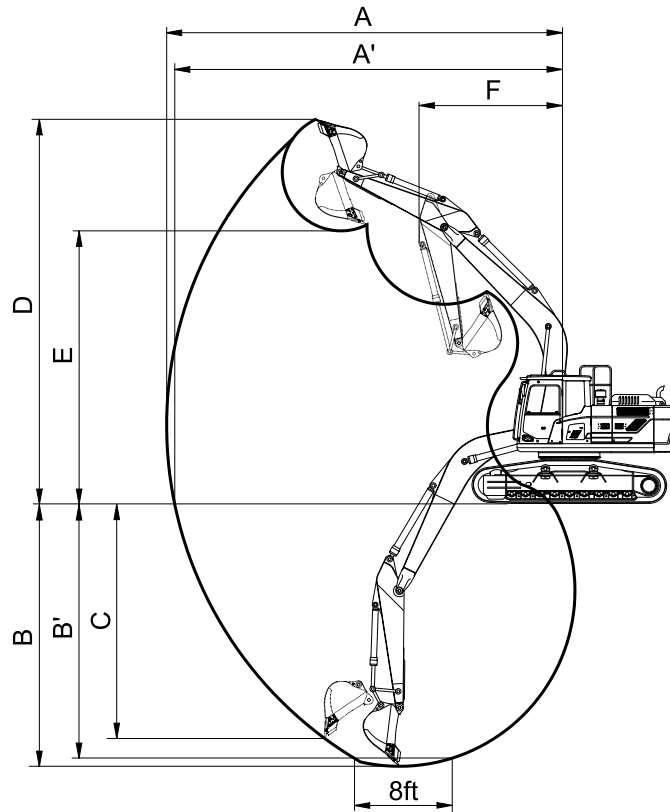

220A2SP07

Description	m (ft-in)	Boom	5.68 (20' 6")			
		Arm	2.92 (9' 7")	2.00 (6' 7")	2.40 (7' 10")	3.90 (12' 10")
Max digging reach		A	9980 (32' 9")	9140 (30' 0")	9500 (31' 2")	10910 (35' 10")
Max digging reach on ground		A'	9820 (32' 3")	8920 (29' 3")	9290 (30' 6")	10730 (35' 2")
Max digging depth		B	6550 (21' 6")	5630 (18' 6")	6010 (19' 9")	7530 (24' 8")
Max digging depth (8 ft level)		B'	6380 (20' 11")	5390 (17' 8")	5820 (19' 1")	7390 (24' 3")
Max vertical wall digging depth		C	6100 (20' 0")	5090 (16' 8")	5630 (18' 6")	7050 (23' 2")
Max digging height		D	9780 (32' 1")	9330 (30' 7")	9530 (31' 3")	10300 (33' 10")
Max dumping height		E	6960 (22' 10")	6520 (21' 5")	6710 (22' 0")	7480 (24' 6")
Min swing radius		F	3670 (12' 0")	3750 (12' 4")	3740 (12' 3")	3700 (12' 2")
Bucket digging force	kN		133.4 [144.8]	133.4 [144.8]	133.4 [144.8]	133.4 [144.8]
	kgf	SAE	13600 [14770]	13600 [14770]	13600 [14770]	13600 [14770]
	lbf		29980 [32560]	29980 [32560]	29980 [32560]	29980 [32560]
	kN		152.0 [165.0]	152.0 [165.0]	152.0 [165.0]	152.0 [165.0]
	kgf	ISO	15500 [16830]	15500 [16830]	15500 [16830]	15500 [16830]
	lbf		34170 [37100]	34170 [37100]	34170 [37100]	34170 [37100]
Arm digging force	kN		102.0 [110.7]	144.2 [156.5]	119.6 [129.9]	84.3 [91.6]
	kgf	SAE	10400 [11290]	14700 [15960]	12200 [13250]	8600 [9340]
	lbf		22930 [24890]	32410 [35190]	26900 [29210]	18960 [20590]
	kN		106.9 [116.0]	151.0 [164.0]	106.9 [116.0]	87.3 [94.7]
	kgf	ISO	10900 [11830]	15400 [16720]	10900 [11830]	8900 [9660]
	lbf		24030 [26080]	33950 [36860]	24030 [26080]	19620 [21300]

[] : Power boost

4. WEIGHT

Item	HX220A L		HX220A LR		HX220A HW	
	kg	lb	kg	lb	kg	lb
Upperstructure assembly						
· Main frame weld assembly	1,890	4,170	1,890	4,170	1,930	4,260
· Engine assembly	583	1,285	583	1,285	583	1,285
· Aftertreatment assembly	74	162	74	162	74	162
· Main pump assembly	140	309	140	309	140	309
· Main control valve assembly	220	485	220	485	220	485
· Swing motor assembly	240	529	240	529	240	529
· Hydraulic oil tank WA	220	485	220	485	220	485
· Fuel tank WA	210	463	210	463	210	463
· Counterweight	3,800	8,380	5,300	11,680	3,800	8,380
· Cab assembly	490	1,080	490	1,080	490	1,080
Lower chassis assembly						
· Track frame weld assembly	2,530	5,580	2,530	5,580	3,605	7,950
· Swing bearing	280	620	280	620	299	660
· Travel motor assembly (2EA)	609	1,340	609	1,340	609	1,340
· Turning joint	57	130	57	130	57	130
· Sprocket (2EA)	112	247	112	247	103	227
· Track recoil spring (2EA)	279	615	279	615	326	719
· Idler (2EA)	301	664	301	664	301	664
· Upper roller (2EA)	93	205	93	205	177	390
· Lower roller (18EA)	797	1,757	797	1,757	797	1,757
· Track-chain assembly (600 mm triple grouser shoe) (2EA)	2,712	5,979	-	-	2,902	6,398
· Track-chain assembly (700 mm triple grouser shoe) (2EA)	3,184	7,020	-	-	3,184	7,020
· Track-chain assembly (800 mm triple grouser shoe) (2EA)	3,468	7,646	3,468	7,646	3,468	7,646
· Track-chain assembly (900 mm triple grouser shoe) (2EA)	3,750	8,267	-	-	3,750	8,267
· Track-chain assembly (700 mm double grouser shoe) (2EA)	3,458	7,624	-	-	3,458	7,624
Front attachment assembly						
· 5.68 m boom assembly	1,520	3,351	-	-	1,520	3,351
· 2.92 m arm assembly	760	1,676	-	-	760	1,676
· 0.92 m³ SAE heaped bucket	820	1,808	-	-	820	1,808
· 8.2 m boom assembly	-	-	2,110	4,652	-	-
· 6.3 m arm assembly	-	-	1,100	2,425	-	-
· 0.52 m³ SAE heaped bucket	-	-	470	1,036	-	-
· Boom cylinder assembly (2EA)	180	397	180	397	180	397
· Arm cylinder assembly	280	617	270	595	280	617
· Bucket cylinder assembly	170	375	100	220	170	375
· Bucket control linkage total	200	441	170	375	200	441

※ This information is different with operating and transportation weight because it is not including harness, pipe, oil, fuel so on.

※ Refer to Transportation for actual weight information and Specifications for operating weight.









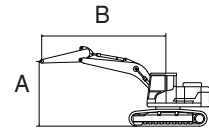

5. LIFTING CAPACITIES

Model	Type	Boom	Arm	Counterweight	Shoe	Wheel	Dozer		Outrigger	
HX220A L	MONO BOOM	Length [mm]	Length [mm]	weight [kg]	width [mm]	width [mm]	Front	Rear	Front	Rear
		5680	2000	3800	600	-	-	-	-	-

·  : Rating over-front

·  : Rating over-side or 360 degree



Lift-point height (A)		Lift-point radius (B)								At max. reach		
		3.0 m (9.8 ft)		4.5 m (14.8 ft)		6.0 m (19.7 ft)		7.5 m (24.6 ft)		Capacity		Reach
												kg
7.5 m (24.6 ft)	kg									*5720	*5720	5.00
	lb									*12610	*12610	(16.4)
6.0 m (19.7 ft)	kg				*5460	5440				*5530	4940	6.35
	lb				*12040	11990				*12190	10890	(20.8)
4.5 m (14.8 ft)	kg			*6900	*6900	*5810	5310			*5570	4040	7.14
	lb			*15210	*15210	*12810	11710			*12280	8910	(23.4)
3.0 m (9.8 ft)	kg			*8690	7640	*6540	5090	5640	3670	5580	3630	7.55
	lb			*19160	16840	*14420	11220	12430	8090	12300	8000	(24.8)
1.5 m (4.9 ft)	kg					*7270	4880	5550	3590	5400	3500	7.64
	lb					*16030	10760	12240	7910	11900	7720	(25.1)
0.0 m (0.0 ft)	kg			*10520	7090	7580	4760			5580	3590	7.43
	lb			*23190	15630	16710	10490			12300	7910	(24.4)
-1.5 m (-4.9 ft)	kg			*10220	7100	7560	4750			6230	3980	6.88
	lb			*22530	15650	16670	10470			13730	8770	(22.6)
-3.0 m (-9.8 ft)	kg	*12370	*12370	*9130	7240					*6670	4980	5.90
	lb	*27270	*27270	*20130	15960					*14700	10980	(19.4)
-4.5 m (-14.8 ft)	kg											
	lb											

Note 1. Lifting capacity are based on ISO 10567.

2. Lifting capacity of the HX series does not exceed 75% of tipping load with the machine on firm, level ground or 87% of full hydraulic capacity.

3. The Lift-point is bucket pivot mounting pin on the arm (without bucket mass).

4. *Indicates load limited by hydraulic capacity.

※ Lifting capacities are based upon a standard machine conditions.

Lifting capacities will vary with different work tools, ground conditions and attachments.

The difference between the weight of a work tool attachment must be subtracted.

Consult with your local Hyundai dealer regarding the lifting capacities for specific work tools and attachments.









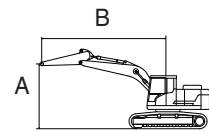

▲ Failure to comply to the rated load can cause serious injury, death, or property damage. Make adjustments to the rated load as necessary for non-standard configurations.

Model	Type	Boom	Arm	Counterweight	Shoe	Wheel	Dozer		Outrigger	
		Length [mm]	Length [mm]	weight [kg]	width [mm]	width [mm]	Front	Rear	Front	Rear
HX220A L	MONO BOOM	5680	2400	3800	600	-	-	-	-	-

·  : Rating over-front

·  : Rating over-side or 360 degree



Lift-point height (A)	Lift-point radius (B)								At max. reach			
	3.0 m (9.8 ft)		4.5 m (14.8 ft)		6.0 m (19.7 ft)		7.5 m (24.6 ft)		Capacity		Reach	
											m (ft)	
7.5 m (24.6 ft)	kg									*5080	*5080	5.58
	lb									*11200	*11200	(18.3)
6.0 m (19.7 ft)	kg				*5010	*5010				*4610	4430	6.82
	lb				*11050	*11050				*10160	9770	(22.4)
4.5 m (14.8 ft)	kg		*6350	*6350	*5450	5340	*5000	3750	*4490	3700	7.55	
	lb		*14000	*14000	*12020	11770	*11020	8270	*9900	8160	(24.8)	
3.0 m (9.8 ft)	kg		*8150	7740	*6230	5110	*5420	3670	*4580	3360	7.94	
	lb		*17970	17060	*13730	11270	*11950	8090	*10100	7410	(26.1)	
1.5 m (4.9 ft)	kg		*9710	7270	*7030	4880	5530	3570	*4860	3230	8.03	
	lb		*21410	16030	*15500	10760	12190	7870	*10710	7120	(26.3)	
0.0 m (0.0 ft)	kg		*10410	7060	7550	4730	5460	3500	5140	3310	7.83	
	lb		*22950	15560	16640	10430	12040	7720	11330	7300	(25.7)	
-1.5 m (-4.9 ft)	kg	*10830	*10830	*10330	7040	7500	4690		5660	3620	7.31	
	lb	*23880	*23880	*22770	15520	16530	10340		12480	7980	(24.0)	
-3.0 m (-9.8 ft)	kg	*13260	*13260	*9490	7140	*6960	4770		*6300	4390	6.40	
	lb	*29230	*29230	*20920	15740	*15340	10520		*13890	9680	(21.0)	
-4.5 m (-14.8 ft)	kg			*7150	*7150				*6320	*6320	4.89	
	lb			*15760	*15760				*13930	*13930	(16.0)	

Note 1. Lifting capacity are based on ISO 10567.

2. Lifting capacity of the HX series does not exceed 75% of tipping load with the machine on firm, level ground or 87% of full hydraulic capacity.

3. The Lift-point is bucket pivot mounting pin on the arm (without bucket mass).

4. *Indicates load limited by hydraulic capacity.

※ Lifting capacities are based upon a standard machine conditions.

Lifting capacities will vary with different work tools, ground conditions and attachments.

The difference between the weight of a work tool attachment must be subtracted.

Consult with your local Hyundai dealer regarding the lifting capacities for specific work tools and attachments.

▲ Failure to comply to the rated load can cause serious injury, death, or property damage. Make adjustments to the rated load as necessary for non-standard configurations.

Model	Type	Boom	Arm	Counterweight	Shoe	Wheel	Dozer		Outrigger	
HX220A L	MONO BOOM	Length [mm]	Length [mm]	weight [kg]	width [mm]	width [mm]	Front	Rear	Front	Rear
		5680	2920	3800	600	-	-	-	-	-



: Rating over-front



: Rating over-side or 360 degree

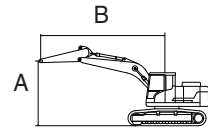

Lift-point height (A)		Lift-point radius (B)										At max. reach				
		1.5 m (4.9 ft)		3.0 m (9.8 ft)		4.5 m (14.8 ft)		6.0 m (19.7 ft)		7.5 m (24.6 ft)		Capacity		Reach		
														kg	lb	m (ft)
7.5 m (24.6 ft)	kg							*4460	*4460					*3370	*3370	6.26
	lb							*9830	*9830					*7430	*7430	(20.5)
6.0 m (19.7 ft)	kg							*4460	*4460					*3100	*3100	7.38
	lb							*9830	*9830					*6830	*6830	(24.2)
4.5 m (14.8 ft)	kg							*4970	*4970	*4710	3780	*3020	*3020	8.07		
	lb							*10960	*10960	*10380	8330	*6660	*6660	(26.5)		
3.0 m (9.8 ft)	kg					*7410	*7410	*5800	5140	*5070	3670	*3070	3050	8.43		
	lb					*16340	*16340	*12790	11330	*11180	8090	*6770	6720	(27.7)		
1.5 m (4.9 ft)	kg					*9140	7340	*6680	4890	*5520	3550	*3250	2940	8.51		
	lb					*20150	16180	*14730	10780	*12170	7830	*7170	6480	(27.9)		
0.0 m (0.0 ft)	kg			*5930	*5930	*10140	7040	*7330	4700	5410	3450	*3590	2990	8.32		
	lb			*13070	*13070	*22350	15520	*16160	10360	11930	7610	*7910	6590	(27.3)		
-1.5 m (-4.9 ft)	kg	*6500	*6500	*10400	*10400	*10350	6950	7440	4620	5380	3420	*4200	3230	7.84		
	lb	*14330	*14330	*22930	*22930	*22820	15320	16400	10190	11860	7540	*9260	7120	(25.7)		
-3.0 m (-9.8 ft)	kg	*11120	*11120	*14180	13660	*9820	7010	*7250	4650			*5420	3800	7.00		
	lb	*24520	*24520	*31260	30120	*21650	15450	*15980	10250			*11950	8380	(23.0)		
-4.5 m (-14.8 ft)	kg			*11610	*11610	*8190	7220					*6080	5250	5.65		
	lb			*25600	*25600	*18060	15920					*13400	11570	(18.5)		

Note 1. Lifting capacity are based on ISO 10567.

- Lifting capacity of the HX series does not exceed 75% of tipping load with the machine on firm, level ground or 87% of full hydraulic capacity.
- The Lift-point is bucket pivot mounting pin on the arm (without bucket mass).
- *Indicates load limited by hydraulic capacity.

※ Lifting capacities are based upon a standard machine conditions.

Lifting capacities will vary with different work tools, ground conditions and attachments.

The difference between the weight of a work tool attachment must be subtracted.

Consult with your local Hyundai dealer regarding the lifting capacities for specific work tools and attachments.









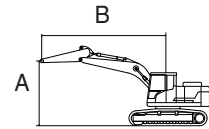





▲ Failure to comply to the rated load can cause serious injury, death, or property damage. Make adjustments to the rated load as necessary for non-standard configurations.

Model	Type	Boom	Arm	Counterweight	Shoe	Wheel	Dozer		Outrigger	
HX220A L	MONO BOOM	Length [mm]	Length [mm]	weight [kg]	width [mm]	width [mm]	Front	Rear	Front	Rear
		5680	2920	3800	800	-	-	-	-	-

·  : Rating over-front

·  : Rating over-side or 360 degree



Lift-point height (A)		Lift-point radius (B)										At max. reach				
		1.5 m (4.9 ft)		3.0 m (9.8 ft)		4.5 m (14.8 ft)		6.0 m (19.7 ft)		7.5 m (24.6 ft)		Capacity		Reach		
																m (ft)
7.5 m (24.6 ft)	kg							*4460	*4460					*3370	*3370	6.26
	lb							*9830	*9830					*7430	*7430	(20.5)
6.0 m (19.7 ft)	kg							*4460	*4460					*3100	*3100	7.38
	lb							*9830	*9830					*6830	*6830	(24.2)
4.5 m (14.8 ft)	kg							*4970	*4970	*4710	3900	*3020	*3020	8.07		
	lb							*10960	*10960	*10380	8600	*6660	*6660	(26.5)		
3.0 m (9.8 ft)	kg					*7410	*7410	*5800	5300	*5070	3790	*3070	*3070	8.43		
	lb					*16340	*16340	*12790	11680	*11180	8360	*6770	*6770	(27.7)		
1.5 m (4.9 ft)	kg					*9140	7570	*6680	5040	*5520	3670	*3250	3040	8.51		
	lb					*20150	16690	*14730	11110	*12170	8090	*7170	6700	(27.9)		
0.0 m (0.0 ft)	kg			*5930	*5930	*10140	7270	*7330	4860	5600	3570	*3590	3090	8.32		
	lb			*13070	*13070	*22350	16030	*16160	10710	12350	7870	*7910	6810	(27.3)		
-1.5 m (-4.9 ft)	kg	*6500	*6500	*10400	*10400	*10350	7180	*7590	4780	5560	3540	*4200	3350	7.84		
	lb	*14330	*14330	*22930	*22930	*22820	15830	*16730	10540	12260	7800	*9260	7390	(25.7)		
-3.0 m (-9.8 ft)	kg	*11120	*11120	*14180	14090	*9820	7240	*7250	4810			*5420	3940	7.00		
	lb	*24520	*24520	*31260	31060	*21650	15960	*15980	10600			*11950	8690	(23.0)		
-4.5 m (-14.8 ft)	kg			*11610	*11610	*8190	7450					*6080	5420	5.65		
	lb			*25600	*25600	*18060	16420					*13400	11950	(18.5)		

Note 1. Lifting capacity are based on ISO 10567.

2. Lifting capacity of the HX series does not exceed 75% of tipping load with the machine on firm, level ground or 87% of full hydraulic capacity.

3. The Lift-point is bucket pivot mounting pin on the arm (without bucket mass).

4. *Indicates load limited by hydraulic capacity.

※ Lifting capacities are based upon a standard machine conditions.

Lifting capacities will vary with different work tools, ground conditions and attachments.

The difference between the weight of a work tool attachment must be subtracted.

Consult with your local Hyundai dealer regarding the lifting capacities for specific work tools and attachments.









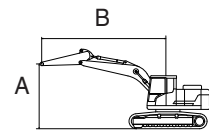





▲ Failure to comply to the rated load can cause serious injury, death, or property damage. Make adjustments to the rated load as necessary for non-standard configurations.

Model	Type	Boom	Arm	Counterweight	Shoe	Wheel	Dozer		Outrigger	
		Length [mm]	Length [mm]	weight [kg]	width [mm]	width [mm]	Front	Rear	Front	Rear
HX220A L	MONO BOOM	5680	3900	3800	600	-	-	-	-	-

·  : Rating over-front

·  : Rating over-side or 360 degree



Lift-point height (A)	Lift-point radius (B)												At max. reach					
	1.5 m (4.9 ft)		3.0 m (9.8 ft)		4.5 m (14.8 ft)		6.0 m (19.7 ft)		7.5 m (24.6 ft)		9.0 m (29.5 ft)		Capacity	Reach				
															m (ft)			
7.5 m (24.6 ft)	kg															*2330	*2330	7.49
	lb															*5140	*5140	(24.6)
6.0 m (19.7 ft)	kg								*3680	*3680					*2170	*2170	8.44	
	lb								*8110	*8110					*4780	*4780	(27.7)	
4.5 m (14.8 ft)	kg								*3920	3820	*2330	*2330	*2120	*2120	*2120	*2120	9.05	
	lb								*8640	8420	*5140	*5140	*4670	*4670	*4670	*4670	(29.7)	
3.0 m (9.8 ft)	kg				*5890	*5890	*4880	*4880	*4370	3680	*3530	2710	*2150	*2150	*2150	*2150	9.37	
	lb				*12990	*12990	*10760	*10760	*9630	8110	*7780	5970	*4740	*4740	*4740	*4740	(30.7)	
1.5 m (4.9 ft)	kg			*8630	*8630	*7850	7470	*5870	4900	*4920	3510	*4080	2630	*2250	*2250	*2250	*2250	9.45
	lb			*19030	*19030	*17310	16470	*12940	10800	*10850	7740	*8990	5800	*4960	*4960	*4960	*4960	(31.0)
0.0 m (0.0 ft)	kg			*7210	*7210	*9310	7000	*6730	4640	5330	3370	*3890	2570	*2440	*2440	*2440	*2440	9.28
	lb			*15900	*15900	*20530	15430	*14840	10230	11750	7430	*8580	5670	*5380	*5380	*5380	*5380	(30.4)
-1.5 m (-4.9 ft)	kg	*5430	*5430	*9370	*9370	*10030	6770	*7260	4480	5240	3280			*2780	2610	2610	8.85	
	lb	*11970	*11970	*20660	*20660	*22110	14930	*16010	9880	11550	7230			*6130	5750	5750	(29.0)	
-3.0 m (-9.8 ft)	kg	*8510	*8510	*13040	*13040	*10030	6730	7250	4440	5220	3270			*3380	2950	2950	8.12	
	lb	*18760	*18760	*28750	*28750	*22110	14840	15980	9790	11510	7210			*7450	6500	6500	(26.6)	
-4.5 m (-14.8 ft)	kg	*12380	*12380	*13530	13400	*9220	6840	*6720	4520					*4660	3700	3700	6.99	
	lb	*27290	*27290	*29830	29540	*20330	15080	*14820	9960					*10270	8160	8160	(22.9)	
-6.0 m (-19.7 ft)	kg			*10120	*10120	*6860	*6860							*5510	*5510	*5510	5.21	
	lb			*22310	*22310	*15120	*15120							*12150	*12150	*12150	(17.1)	

Note 1. Lifting capacity are based on ISO 10567.

2. Lifting capacity of the HX series does not exceed 75% of tipping load with the machine on firm, level ground or 87% of full hydraulic capacity.

3. The Lift-point is bucket pivot mounting pin on the arm (without bucket mass).

4. *Indicates load limited by hydraulic capacity.

※ Lifting capacities are based upon a standard machine conditions.

Lifting capacities will vary with different work tools, ground conditions and attachments.

The difference between the weight of a work tool attachment must be subtracted.

Consult with your local Hyundai dealer regarding the lifting capacities for specific work tools and attachments.









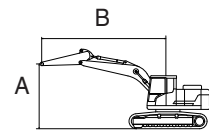

▲ Failure to comply to the rated load can cause serious injury, death, or property damage. Make adjustments to the rated load as necessary for non-standard configurations.

Model	Type	Boom	Arm	Counterweight	Shoe	Wheel	Dozer		Outrigger	
		Length [mm]	Length [mm]	weight [kg]	width [mm]	width [mm]	Front	Rear	Front	Rear
HX220A L	2-PIECE BOOM	5650	2920	3800	600	-	-	-	-	-

·  : Rating over-front

·  : Rating over-side or 360 degree



Lift-point height (A)	Lift-point radius (B)								At max. reach			
	3.0 m (9.8 ft)		4.5 m (14.8 ft)		6.0 m (19.7 ft)		7.5 m (24.6 ft)		Capacity		Reach	
											m (ft)	
9.0 m (29.5 ft)	kg									*4550	*4550	4.46
	lb									*10030	*10030	(14.6)
7.5 m (24.6 ft)	kg		*6200	*6200	*5300	*5300				*3630	*3630	6.32
	lb		*13670	*13670	*11680	*11680				*8000	*8000	(20.7)
6.0 m (19.7 ft)	kg		*6430	*6430	*5760	5560				*3300	*3300	7.43
	lb		*14180	*14180	*12700	12260				*7280	*7280	(24.4)
4.5 m (14.8 ft)	kg	*10530	*10530	*8050	*8050	*6090	5370	*4920	3730	*3180	*3180	8.11
	lb	*23210	*23210	*17750	*17750	*13430	11840	*10850	8220	*7010	*7010	(26.6)
3.0 m (9.8 ft)	kg		*10100	7820	*6730	5080	*5130	3610	*3200	2950	8.47	
	lb		*22270	17240	*14840	11200	*11310	7960	*7050	6500	(27.8)	
1.5 m (4.9 ft)	kg		*11830	7210	*7620	4800	*5440	3470	*3350	2840	8.55	
	lb		*26080	15900	*16800	10580	*11990	7650	*7390	6260	(28.1)	
0.0 m (0.0 ft)	kg		11830	6880	7480	4590	5370	3370	*3640	2890	8.36	
	lb		26080	15170	16490	10120	11840	7430	*8020	6370	(27.4)	
-1.5 m (-4.9 ft)	kg	*11710	*11710	*10960	6790	7380	4510	5340	3340	*4180	3140	7.88
	lb	*25820	*25820	*24160	14970	16270	9940	11770	7360	*9220	6920	(25.9)
-3.0 m (-9.8 ft)	kg	*11250	*11250	*8920	6870	*6680	4560			*4770	3710	7.05
	lb	*24800	*24800	*19670	15150	*14730	10050			*10520	8180	(23.1)

Note 1. Lifting capacity are based on ISO 10567.

- Lifting capacity of the HX series does not exceed 75% of tipping load with the machine on firm, level ground or 87% of full hydraulic capacity.
- The Lift-point is bucket pivot mounting pin on the arm (without bucket mass).
- *Indicates load limited by hydraulic capacity.

※ Lifting capacities are based upon a standard machine conditions.

Lifting capacities will vary with different work tools, ground conditions and attachments.

The difference between the weight of a work tool attachment must be subtracted.

Consult with your local Hyundai dealer regarding the lifting capacities for specific work tools and attachments.









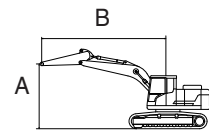

▲ Failure to comply to the rated load can cause serious injury, death, or property damage. Make adjustments to the rated load as necessary for non-standard configurations.

Model	Type	Boom	Arm	Counterweight	Shoe	Wheel	Dozer		Outrigger	
		Length [mm]	Length [mm]	weight [kg]	width [mm]	width [mm]	Front	Rear	Front	Rear
HX220A L	2-PIECE BOOM	5650	2920	5300	600	-	-	-	-	-

·  : Rating over-front

·  : Rating over-side or 360 degree



Lift-point height (A)	Lift-point radius (B)								At max. reach			
	3.0 m (9.8 ft)		4.5 m (14.8 ft)		6.0 m (19.7 ft)		7.5 m (24.6 ft)		Capacity		Reach	
											m (ft)	
9.0 m (29.5 ft)	kg									*3940	*3940	4.46
	lb									*8690	*8690	(14.6)
7.5 m (24.6 ft)	kg			*6020	*6020	*4590	*4590			*3130	*3130	6.32
	lb			*13270	*13270	*10120	*10120			*6900	*6900	(20.7)
6.0 m (19.7 ft)	kg			*6170	*6170	*4950	*4950			*2830	*2830	7.43
	lb			*13600	*13600	*10910	*10910			*6240	*6240	(24.4)
4.5 m (14.8 ft)	kg	*9140	*9140	*6930	*6930	*5220	*5220	*4200	*4200	*2730	*2730	8.11
	lb	*20150	*20150	*15280	*15280	*11510	*11510	*9260	*9260	*6020	*6020	(26.6)
3.0 m (9.8 ft)	kg			*8690	*8690	*5770	*5770	*4380	4290	*2750	*2750	8.47
	lb			*19160	*19160	*12720	*12720	*9660	9460	*6060	*6060	(27.8)
1.5 m (4.9 ft)	kg			*10100	8540	*6520	5700	*4640	4160	*2870	*2870	8.55
	lb			*22270	18830	*14370	12570	*10230	9170	*6330	*6330	(28.1)
0.0 m (0.0 ft)	kg			*10150	8220	*7260	5500	*4890	4060	*3130	*3130	8.36
	lb			*22380	18120	*16010	12130	*10780	8950	*6900	*6900	(27.4)
-1.5 m (-4.9 ft)	kg	*10190	*10190	*9300	8130	*6970	5420	*5040	4030	*3600	*3600	7.88
	lb	*22470	*22470	*20500	17920	*15370	11950	*11110	8880	*7940	*7940	(25.9)
-3.0 m (-9.8 ft)	kg	*9460	*9460	*7530	*7530	*5620	5470			*3990	*3990	7.05
	lb	*20860	*20860	*16600	*16600	*12390	12060			*8800	*8800	(23.1)

Note 1. Lifting capacity are based on ISO 10567.

- Lifting capacity of the HX series does not exceed 75% of tipping load with the machine on firm, level ground or 87% of full hydraulic capacity.
- The Lift-point is bucket pivot mounting pin on the arm (without bucket mass).
- *Indicates load limited by hydraulic capacity.

※ Lifting capacities are based upon a standard machine conditions.

Lifting capacities will vary with different work tools, ground conditions and attachments.

The difference between the weight of a work tool attachment must be subtracted.

Consult with your local Hyundai dealer regarding the lifting capacities for specific work tools and attachments.

▲ Failure to comply to the rated load can cause serious injury, death, or property damage. Make adjustments to the rated load as necessary for non-standard configurations.

Model	Type	Boom	Arm	Counterweight	Shoe	Wheel	Dozer		Outrigger	
HX220A L	LONG REACH	Length [mm]	Length [mm]	weight [kg]	width [mm]	width [mm]	Front	Rear	Front	Rear
		8200	6300	5300	800	-	-	-	-	-



Rating over-front



Rating over-side or 360 degree

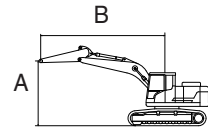

Lift-point height (A)	Lift-point radius (B)																		At max. reach							
	1.5 m (4.9 ft)		3.0 m (9.8 ft)		4.5 m (14.8 ft)		6.0 m (19.7 ft)		7.5 m (24.6 ft)		9.0 m (29.5 ft)		10.5 m (34.4 ft)		12.0 m (39.4 ft)		13.5 m (44.3 ft)		Capacity	Reach						
																					m (ft)					
10.5m 34.4ft	kg lb													*1180 *2600	*1180 *2600					*870 *1920	*870 *1920	10.88 (35.7)				
9.0m 29.5ft	kg lb																			*820 *1810	*820 *1810	11.94 (39.2)				
7.5m 24.6ft	kg lb													*1870 *4120	*1870 *4120	*1410 *3110	*1410 *3110			*790 *1740	*790 *1740	12.74 (41.8)				
6.0m 19.7ft	kg lb													*1990 *4390	*1990 *4390	*1780 *3920	*1780 *3920			*790 *1740	*790 *1740	13.31 (43.7)				
4.5m 14.8ft	kg lb													*2290 *5050	*2290 *5050	*2170 *4780	*2170 *4780	*2080 *4590	*2080 *4590	*1050 *2310	*1050 *2310	*800 *1760	*800 *1760	13.70 (45.0)		
3.0m 9.8ft	kg lb													*2980 *6570	*2980 *6570	*2630 *5800	*2630 *5800	*2400 *5290	*2400 *5290	*2250 *4960	2000 4410	*1340 *2950	*1340 *2950	*830 *1830	*830 *1830	13.92 (45.7)
1.5m 4.9ft	kg lb			*2800 *6170	*2800 *6170	*6330 *13960	*6330 *13960	*4470 *9850	*4470 *9850	*3530 *7780	*3530 *7780	*2990 *6590	*2990 *6590	*2640 *5820	2400 5290	*2410 *5310	1910 4210	*1490 *3280	*1490 *3280	*880 *1940	*880 *1940	*880 *1940	*880 *1940	13.97 (45.8)		
0.0m 0.0ft	kg lb			*2410 *5310	*2410 *5310	*6270 *13820	*6270 *13820	*5260 *11600	5020 11070	*4050 *8930	3710 8180	*3340 *7360	2870 6330	*2880 *6350	2270 5000	*2580 *5690	1830 4030	*1470 *3240	*1470 *3240	*950 *2090	*950 *2090	*950 *2090	*950 *2090	13.85 (45.4)		
-1.5m -4.9ft	kg lb	*1990 *4390	*1990 *4390	*2980 *6570	*2980 *6570	*5610 *12370	*5610 *12370	*5830 *12850	4690 10340	*4460 *9830	3480 7670	*3630 *8000	2710 5970	*3090 *6810	2160 4760	*2720 *6000	1760 3880	*1170 *2580	*1170 *2580	*1040 *2290	*1040 *2290	13.57 (44.5)				
-3.0m -9.8ft	kg lb	*2870 *6330	*2870 *6330	*3800 *8380	*3800 *8380	*6050 *13340	*6050 *13340	*6170 *13600	4510 9940	*4750 *10470	3330 7340	*3850 *8490	2600 5730	*3250 *7170	2090 4610	*2810 *6190	1710 3770			*1180 *2600	*1180 *2600	13.11 (43.0)				
-4.5m -14.8ft	kg lb	*3790 *8360	*3790 *8360	*4800 *10580	*4800 *10580	*7020 *15480	6750 14880	*6290 *13870	4450 9810	*4880 *10760	3270 7210	*3960 *8730	2540 5600	*3320 *7320	2050 4520	*2380 *5250	1700 3750			*1390 *3060	*1390 *3060	12.45 (40.9)				
-6.0m -19.7ft	kg lb	*4800 *10580	*4800 *10580	*5970 *13160	*5970 *13160	*8340 *18390	6840 15080	*6190 *13650	4470 9850	*4850 *10690	3270 7210	*3930 *8660	2550 5620	*3250 *7170	2070 4560					*1720 *3790	*1720 *3790	11.56 (37.9)				
-7.5m -24.6ft	kg lb	*5950 *13120	*5950 *13120	*7410 *16340	*7410 *16340	*7740 *17060	7040 15520	*5830 *12850	4590 10120	*4600 *10140	3350 7390	*3700 *8160	2620 5780							*2300 *5070	2190 4830	10.37 (34.0)				
-9.0m -29.5ft	kg lb			*9290 *20480	*9290 *20480	*6700 *14770	*6700 *14770	*5100 *11240	4790 10560	*3980 *8770	3520 7760									*3160 *6970	2880 6350	8.77 (28.8)				
-10.5m -34.4ft	kg lb																									

Note 1. Lifting capacity are based on ISO 10567.

2. Lifting capacity of the HX series does not exceed 75% of tipping load with the machine on firm, level ground or 87% of full hydraulic capacity.

3. The Lift-point is bucket pivot mounting pin on the arm (without bucket mass).

4. *Indicates load limited by hydraulic capacity.

※ Lifting capacities are based upon a standard machine conditions.

Lifting capacities will vary with different work tools, ground conditions and attachments.

The difference between the weight of a work tool attachment must be subtracted.

Consult with your local Hyundai dealer regarding the lifting capacities for specific work tools and attachments.









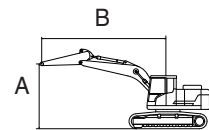

▲ Failure to comply to the rated load can cause serious injury, death, or property damage. Make adjustments to the rated load as necessary for non-standard configurations.

Model	Type	Boom	Arm	Counterweight	Shoe	Wheel	Dozer		Outrigger	
		Length [mm]	Length [mm]	weight [kg]	width [mm]	width [mm]	Front	Rear	Front	Rear
HX220A HW	MONO BOOM	5680	2000	3800	600	-	-	-	-	-

·  : Rating over-front

·  : Rating over-side or 360 degree



Lift-point height (A)	Lift-point radius (B)								At max. reach			
	3.0 m (9.8 ft)		4.5 m (14.8 ft)		6.0 m (19.7 ft)		7.5 m (24.6 ft)		Capacity		Reach	
											m (ft)	
7.5 m (24.6 ft)	kg									*5670	*5670	5.23
	lb									*12500	*12500	(17.1)
6.0 m (19.7 ft)	kg				*5470	*5470				*5530	5060	6.48
	lb				*12060	*12060				*12190	11160	(21.3)
4.5 m (14.8 ft)	kg		*7120	*7120	*5900	5600				*5580	4220	7.21
	lb		*15700	*15700	*13010	12350				*12300	9300	(23.7)
3.0 m (9.8 ft)	kg		*8930	8030	*6650	5370	*5740	3900		*5720	3840	7.58
	lb		*19690	17700	*14660	11840	*12650	8600		*12610	8470	(24.9)
1.5 m (4.9 ft)	kg				*7340	5170	5910	3820		5760	3730	7.63
	lb				*16180	11400	13030	8420		12700	8220	(25.0)
0.0 m (0.0 ft)	kg		*10520	7550	*7710	5070				6010	3870	7.37
	lb		*23190	16640	*17000	11180				13250	8530	(24.2)
-1.5 m (-4.9 ft)	kg	*12400	*12400	*10130	7580	*7550	5070			*6470	4340	6.78
	lb	*27340	*27340	*22330	16710	*16640	11180			*14260	9570	(22.2)
-3.0 m (-9.8 ft)	kg	*12040	*12040	*8890	7730					*6690	5540	5.73
	lb	*26540	*26540	*19600	17040					*14750	12210	(18.8)
-4.5 m (-14.8 ft)	kg											
	lb											

Note 1. Lifting capacity are based on ISO 10567.

- Lifting capacity of the HX series does not exceed 75% of tipping load with the machine on firm, level ground or 87% of full hydraulic capacity.
- The Lift-point is bucket pivot mounting pin on the arm (without bucket mass).
- *Indicates load limited by hydraulic capacity.

※ Lifting capacities are based upon a standard machine conditions.

Lifting capacities will vary with different work tools, ground conditions and attachments.

The difference between the weight of a work tool attachment must be subtracted.

Consult with your local Hyundai dealer regarding the lifting capacities for specific work tools and attachments.









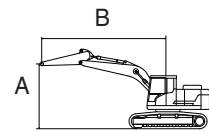

▲ Failure to comply to the rated load can cause serious injury, death, or property damage. Make adjustments to the rated load as necessary for non-standard configurations.

Model	Type	Boom	Arm	Counterweight	Shoe	Wheel	Dozer		Outrigger	
HX220A HW	MONO BOOM	Length [mm]	Length [mm]	weight [kg]	width [mm]	width [mm]	Front	Rear	Front	Rear
		5680	2400	3800	600	-	-	-	-	-

·  : Rating over-front

·  : Rating over-side or 360 degree



Lift-point height (A)	Lift-point radius (B)								At max. reach			
	3.0 m (9.8 ft)		4.5 m (14.8 ft)		6.0 m (19.7 ft)		7.5 m (24.6 ft)		Capacity		Reach	
											m (ft)	
7.5 m (24.6 ft)	kg									*4990	*4990	5.79
	lb									*11000	*11000	(19.0)
6.0 m (19.7 ft)	kg				*5040	*5040				*4580	4560	6.94
	lb				*11110	*11110				*10100	10050	(22.8)
4.5 m (14.8 ft)	kg		*6570	*6570	*5540	*5540	*5190	3980	*4490	3870	7.62	
	lb		*14480	*14480	*12210	*12210	*11440	8770	*9900	8530	(25.0)	
3.0 m (9.8 ft)	kg		*8390	8120	*6350	5390	*5470	3900	*4600	3550	7.97	
	lb		*18500	17900	*14000	11880	*12060	8600	*10140	7830	(26.1)	
1.5 m (4.9 ft)	kg		*9850	7690	*7120	5170	*5830	3800	*4920	3450	8.02	
	lb		*21720	16950	*15700	11400	*12850	8380	*10850	7610	(26.3)	
0.0 m (0.0 ft)	kg		*10440	7510	*7600	5040	5820	3730	*5520	3560	7.78	
	lb		*23020	16560	*16760	11110	12830	8220	*12170	7850	(25.5)	
-1.5 m (-4.9 ft)	kg	*11820	*11820	*10270	7500	*7600	5010		*6070	3940	7.22	
	lb	*26060	*26060	*22640	16530	*16760	11050		*13380	8690	(23.7)	
-3.0 m (-9.8 ft)	kg	*12960	*12960	*9300	7620	*6760	5110		*6330	4860	6.25	
	lb	*28570	*28570	*20500	16800	*14900	11270		*13960	10710	(20.5)	
-4.5 m (-14.8 ft)	kg											
	lb											

Note 1. Lifting capacity are based on ISO 10567.

2. Lifting capacity of the HX series does not exceed 75% of tipping load with the machine on firm, level ground or 87% of full hydraulic capacity.

3. The Lift-point is bucket pivot mounting pin on the arm (without bucket mass).

4. *Indicates load limited by hydraulic capacity.

※ Lifting capacities are based upon a standard machine conditions.

Lifting capacities will vary with different work tools, ground conditions and attachments.

The difference between the weight of a work tool attachment must be subtracted.

Consult with your local Hyundai dealer regarding the lifting capacities for specific work tools and attachments.









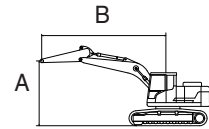



▲ Failure to comply to the rated load can cause serious injury, death, or property damage. Make adjustments to the rated load as necessary for non-standard configurations.

Model	Type	Boom	Arm	Counterweight	Shoe	Wheel	Dozer		Outrigger	
HX220A HW	MONO BOOM	Length [mm]	Length [mm]	weight [kg]	width [mm]	width [mm]	Front	Rear	Front	Rear
		5680	2920	3800	600	-	-	-	-	-

·  : Rating over-front

·  : Rating over-side or 360 degree



Lift-point height (A)	Lift-point radius (B)										At max. reach			
	1.5 m (4.9 ft)		3.0 m (9.8 ft)		4.5 m (14.8 ft)		6.0 m (19.7 ft)		7.5 m (24.6 ft)		Capacity		Reach	
													m (ft)	
7.5 m (24.6 ft)	kg							*4490	*4490			*3320	*3320	6.44
	lb							*9900	*9900			*7320	*7320	(21.1)
6.0 m (19.7 ft)	kg							*4500	*4500			*3080	*3080	7.49
	lb							*9920	*9920			*6790	*6790	(24.6)
4.5 m (14.8 ft)	kg							*5070	*5070	*4750	4010	*3020	*3020	8.13
	lb							*11180	*11180	*10470	8840	*6660	*6660	(26.7)
3.0 m (9.8 ft)	kg				*7670	*7670	*5920	5420	*5130	3900	*3090	*3090	8.46	
	lb				*16910	*16910	*13050	11950	*11310	8600	*6810	*6810	(27.7)	
1.5 m (4.9 ft)	kg				*9330	7740	*6780	5170	*5570	3770	*3290	3140	8.50	
	lb				*20570	17060	*14950	11400	*12280	8310	*7250	6920	(27.9)	
0.0 m (0.0 ft)	kg		*6460	*6460	*10210	7480	*7390	5000	5770	3680	*3650	3220	8.28	
	lb		*14240	*14240	*22510	16490	*16290	11020	12720	8110	*8050	7100	(27.2)	
-1.5 m (-4.9 ft)	kg	*7100	*7100	*11080	*11080	*10330	7410	*7580	4930	5750	3660	*4320	3510	7.75
	lb	*15650	*15650	*24430	*24430	*22770	16340	*16710	10870	12680	8070	*9520	7740	(25.4)
-3.0 m (-9.8 ft)	kg	*11800	*11800	*13920	*13920	*9690	7480	*7130	4980			*5670	4190	6.86
	lb	*26010	*26010	*30690	*30690	*21360	16490	*15720	10980			*12500	9240	(22.5)
-4.5 m (-14.8 ft)	kg			*11110	*11110	*7820	7730					*6090	5970	5.42
	lb			*24490	*24490	*17240	17040					*13430	13160	(17.8)

Note 1. Lifting capacity are based on ISO 10567.

2. Lifting capacity of the HX series does not exceed 75% of tipping load with the machine on firm, level ground or 87% of full hydraulic capacity.

3. The Lift-point is bucket pivot mounting pin on the arm (without bucket mass).

4. *Indicates load limited by hydraulic capacity.

※ Lifting capacities are based upon a standard machine conditions.

Lifting capacities will vary with different work tools, ground conditions and attachments.

The difference between the weight of a work tool attachment must be subtracted.

Consult with your local Hyundai dealer regarding the lifting capacities for specific work tools and attachments.

▲ Failure to comply to the rated load can cause serious injury, death, or property damage. Make adjustments to the rated load as necessary for non-standard configurations.

Model	Type	Boom	Arm	Counterweight	Shoe	Wheel	Dozer		Outrigger	
HX220A HW	MONO BOOM	Length [mm]	Length [mm]	weight [kg]	width [mm]	width [mm]	Front	Rear	Front	Rear
		5680	3900	3800	600	-	-	-	-	-



: Rating over-front



: Rating over-side or 360 degree

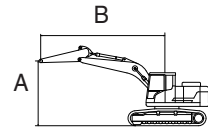

Lift-point height (A)	Lift-point radius (B)												At max. reach			
	1.5 m (4.9 ft)		3.0 m (9.8 ft)		4.5 m (14.8 ft)		6.0 m (19.7 ft)		7.5 m (24.6 ft)		9.0 m (29.5 ft)		Capacity	Reach		
															m (ft)	
7.5 m (24.6 ft)	kg									*2760	*2760			*2300	*2300	7.64
	lb									*6080	*6080			*5070	*5070	(25.1)
6.0 m (19.7 ft)	kg									*3690	*3690			*2160	*2160	8.54
	lb									*8140	*8140			*4760	*4760	(28.0)
4.5 m (14.8 ft)	kg							*4100	*4100	*3970	*3970	*2560	*2560	*2120	*2120	9.11
	lb							*9040	*9040	*8750	*8750	*5640	*5640	*4670	*4670	(29.9)
3.0 m (9.8 ft)	kg			*9120	*9120	*6160	*6160	*5010	*5010	*4440	3890	*3630	2900	*2150	*2150	9.40
	lb			*20110	*20110	*13580	*13580	*11050	*11050	*9790	8580	*8000	6390	*4740	*4740	(30.8)
1.5 m (4.9 ft)	kg			*7910	*7910	*8080	7850	*6000	5170	*4990	3730	*4110	2820	*2270	*2270	9.44
	lb			*17440	*17440	*17810	17310	*13230	11400	*11000	8220	*9060	6220	*5000	*5000	(31.0)
0.0 m (0.0 ft)	kg			*7390	*7390	*9450	7410	*6820	4920	*5470	3590	*3760	2750	*2480	*2480	9.23
	lb			*16290	*16290	*20830	16340	*15040	10850	*12060	7910	*8290	6060	*5470	*5470	(30.3)
-1.5 m (-4.9 ft)	kg	*5820	*5820	*9770	*9770	*10070	7210	*7300	4780	5590	3510			*2840	2840	8.77
	lb	*12830	*12830	*21540	*21540	*22200	15900	*16090	10540	12320	7740			*6260	6260	(28.8)
-3.0 m (-9.8 ft)	kg	*8970	*8970	*13670	*13670	*9970	7190	*7310	4750	5600	3510			*3500	3240	7.99
	lb	*19780	*19780	*30140	*30140	*21980	15850	*16120	10470	12350	7740			*7720	7140	(26.2)
-4.5 m (-14.8 ft)	kg	*13000	*13000	*13200	*13200	*9020	7330	*6540	4860					*4940	4130	6.80
	lb	*28660	*28660	*29100	*29100	*19890	16160	*14420	10710					*10890	9110	(22.3)
-6.0 m (-19.7 ft)	kg					*6270	*6270									
	lb					*13820	*13820									

Note 1. Lifting capacity are based on ISO 10567.

2. Lifting capacity of the HX series does not exceed 75% of tipping load with the machine on firm, level ground or 87% of full hydraulic capacity.

3. The Lift-point is bucket pivot mounting pin on the arm (without bucket mass).

4. *Indicates load limited by hydraulic capacity.

※ Lifting capacities are based upon a standard machine conditions.

Lifting capacities will vary with different work tools, ground conditions and attachments.

The difference between the weight of a work tool attachment must be subtracted.

Consult with your local Hyundai dealer regarding the lifting capacities for specific work tools and attachments.

▲ Failure to comply to the rated load can cause serious injury, death, or property damage. Make adjustments to the rated load as necessary for non-standard configurations.

Model	Type	Boom	Arm	Counterweight	Shoe	Wheel	Dozer		Outrigger	
HX220A HW	LONG REACH	Length [mm]	Length [mm]	weight [kg]	width [mm]	width [mm]	Front	Rear	Front	Rear
		8200	6300	5300	800	-	-	-	-	-



: Rating over-front



: Rating over-side or 360 degree

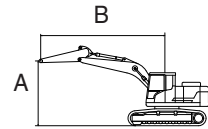

Lift-point height (A)		Lift-point radius (B)																		At max. reach			
		1.5 m (4.9 ft)		3.0 m (9.8 ft)		4.5 m (14.8 ft)		6.0 m (19.7 ft)		7.5 m (24.6 ft)		9.0 m (29.5 ft)		10.5 m (34.4 ft)		12.0 m (39.4 ft)		13.5 m (44.3 ft)		Capacity	Reach		
																						m (ft)	
10.5m 34.4ft	kg lb													*1280 *2820	*1280 *2820					*860 *1900	*860 *1900	11.04 (36.2)	
9.0m 29.5ft	kg lb															*880 *1940	*880 *1940			*810 *1790	*810 *1790	12.06 (39.6)	
7.5m 24.6ft	kg lb													*1880 *4140	*1880 *4140	*1470 *3240	*1470 *3240			*790 *1740	*790 *1740	12.82 (42.1)	
6.0m 19.7ft	kg lb													*2010 *4430	*2010 *4430	*1820 *4010	*1820 *4010			*790 *1740	*790 *1740	13.38 (43.9)	
4.5m 14.8ft	kg lb												*2330 *5140	*2330 *5140	*2200 *4850	*2200 *4850	*2120 *4670	*2120 *4670	*1090 *2400	*1090 *2400	*800 *1760	*800 *1760	13.74 (45.1)
3.0m 9.8ft	kg lb						*3680 *8110	*3680 *8110	*3050 *6720	*3050 *6720	*2670 *5890	*2670 *5890	*2430 *5360	*2430 *5360	*2270 *5000	2110 4650	*1360 *3000	*1360 *3000	*830 *1830	*830 *1830	13.93 (45.7)		
1.5m 4.9ft	kg lb			*2610 *5750	*2610 *5750	*6530 *14400	*6530 *14400	*4580 *10100	*4580 *10100	*3610 *7960	*3610 *7960	*3040 *6700	*3040 *6700	*2670 *5890	2530 5580	*2430 *5360	2020 4450	*1490 *3280	*1490 *3280	*880 *1940	*880 *1940	13.96 (45.8)	
0.0m 0.0ft	kg lb			*2460 *5420	*2460 *5420	*6060 *13360	*6060 *13360	*5350 *11790	5250 11570	*4110 *9060	3890 8580	*3380 *7450	3010 6640	*2910 *6420	2390 5270	*2600 *5730	1940 4280	*1450 *3200	*1450 *3200	*960 *2120	*960 *2120	13.83 (45.4)	
-1.5m -4.9ft	kg lb	*2110 *4650	*2110 *4650	*3080 *6790	*3080 *6790	*5620 *12390	*5620 *12390	*5890 *12990	4940 10890	*4510 *9940	3670 8090	*3670 *8090	2860 6310	*3120 *6880	2290 5050	*2730 *6020	1870 4120	*1100 *2430	*1100 *2430	*1060 *2340	*1060 *2340	13.52 (44.4)	
-3.0m -9.8ft	kg lb	*2990 *6590	*2990 *6590	*3930 *8660	*3930 *8660	*6160 *13580	*6160 *13580	*6200 *13670	4770 10520	*4770 *10520	3530 7780	*3870 *8530	2760 6080	*3260 *7190	2220 4890	*2820 *6220	1830 4030			*1210 *2670	*1210 *2670	13.03 (42.8)	
-4.5m -14.8ft	kg lb	*3920 *8640	*3920 *8640	*4940 *10890	*4940 *10890	*7180 *15830	7160 15790	*6290 *13870	4720 10410	*4890 *10780	3470 7650	*3970 *8750	2710 5970	*3320 *7320	2190 4830	*2210 *4870	1830 4030			*1430 *3150	*1430 *3150	12.35 (40.5)	
-6.0m -19.7ft	kg lb	*4950 *10910	*4950 *10910	*6150 *13560	*6150 *13560	*8280 *18250	7270 16030	*6160 *13580	4760 10490	*4830 *10650	3490 7690	*3920 *8640	2720 6000	*3230 *7120	2220 4890					*1780 *3920	*1780 *3920	11.42 (37.5)	
-7.5m -24.6ft	kg lb	*6110 *13470	*6110 *13470	*7630 *16820	*7630 *16820	*7630 *16820	7480 16490	*5760 *12700	4880 10760	*4540 *10010	3570 7870	*3640 *8020	2800 6170							*2410 *5310	2400 5290	10.19 (33.4)	
-9.0m -29.5ft	kg lb			*9180 *20240	*9180 *20240	*6510 *14350	*6510 *14350	*4960 *10930	*4960 *10930	*3850 *8490	3760 8290									*3190 *7030	*3190 *7030	8.51 (27.9)	
-10.5m -34.4ft	kg lb																						

Note 1. Lifting capacity are based on ISO 10567.

2. Lifting capacity of the HX series does not exceed 75% of tipping load with the machine on firm, level ground or 87% of full hydraulic capacity.

3. The Lift-point is bucket pivot mounting pin on the arm (without bucket mass).

4. *Indicates load limited by hydraulic capacity.

※ Lifting capacities are based upon a standard machine conditions.

Lifting capacities will vary with different work tools, ground conditions and attachments.

The difference between the weight of a work tool attachment must be subtracted.

Consult with your local Hyundai dealer regarding the lifting capacities for specific work tools and attachments.

▲ Failure to comply to the rated load can cause serious injury, death, or property damage. Make adjustments to the rated load as necessary for non-standard configurations.

6. BUCKET SELECTION GUIDE

1) BUCKET SELECTION



General bucket



Heavy duty
(without side cutter)



Rock heavy duty

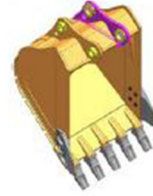

Long reach

Type	Capacity		Width	Weight	Tooth	MONO				2-PIECE			L/Reach			
	SAE Heaped	CECE heaped	Without side cutter			Recommendation										
						5.68 m (18' 8") Boom				5.65 m (18' 6") Boom				8.2 m (26' 11") Boom		
						2.0 m (6' 7") Arm	2.4 m (7' 10") Arm	2.92 m (9' 7") Arm	3.9 m (12' 10") Arm	2.0m (6' 7") Arm	2.4 m (7' 10") Arm	2.92 m (9' 7") Arm			6.3 m (20' 8") Arm	
General bucket	0.80 (1.05)	0.70 (0.92)	1,070 (42.1")	770 (1,700)	5	●	●	●	◐	●	●	●	X			
	0.92 (1.20)	0.80 (1.05)	1,190 (46.9")	820 (1,810)	5	●	●	●	■	●	●	●	X			
	1.10 (1.44)	0.96 (1.26)	1,375 (54.1")	890 (1,960)	5	●	●	◐	▲	●	◐	■	X			
	1.20 (1.57)	1.05 (1.37)	1,390 (54.7")	920 (2,030)	5	●	◐	■	▲	◐	◐	■	X			
	1.34 (1.75)	1.17 (1.53)	1,525 (60.0")	990 (2,180)	6	◐	■	▲	X	◐	■	▲	X			
Heavy duty	0.90 (1.18)	0.79 (1.03)	1,210 (47.6")	880 (1,940)	5	●	●	●	■	●	●	●	X			
	1.05 (1.37)	0.92 (1.20)	1,355 (53.3")	940 (2,070)	5	●	●	◐	▲	●	●	◐	X			
Rock heavy duty	0.87 (1.14)	0.77 (1.01)	1,195 (47.0")	940 (2,070)	5	●	●	●	-	●	●	●	X			
	1.20 (1.57)	1.05 (1.37)	1,520 (59.8")	1,120 (2,470)	6	◐	◐	■	-	◐	■	■	X			
LR	0.52 (0.68)	0.45 (0.59)	945 (37.2")	460 (1,010)	5	X	X	X	X	X	X	X	◐			

●	Applicable for materials with density of 2100 kg/m ³ (3500 lb/yd ³) or less
◐	Applicable for materials with density of 1800 kg/m ³ (3000 lb/yd ³) or less
■	Applicable for materials with density of 1500 kg/m ³ (2500 lb/yd ³) or less
▲	Applicable for materials with density of 1200 kg/m ³ (2000 lb/yd ³) or less
X	Not recommended

※ These recommendations are for general conditions and average use.

Work tools and ground conditions have effects on machine performance.

Select an optimum combination according to the working conditions and the type of work that is being done.

Consult with your local Hyundai dealer for information on selecting the correct boom—arm—bucket combination.

7. UNDERCARRIAGE

1) TYPES OF SHOES

Model	Description	Unit		Triple grouser								Double grouser	
		width	mm	(in)	600	(24)	700	(28)	800	(32)	900	(36)	700
HX220A L	Operating weight	kg	(lb)	22280	49120	22760	50180	23040	50790	23320	51410	23040	50790
	Ground pressure	kgf/cm ²	(psi)	0.48	6.76	0.42	5.92	0.37	5.25	0.33	4.72	0.42	5.99
	Overall width	mm	(ft-in)	2990	9'10"	3090	10'2"	3190	10'6"	3290	10'10"	3090	10'2"
	Link quantity	EA		49		49		49		49		49	
HX220A LR	Operating weight	kg	(lb)	-	-	-	-	25460	56130	-	-	-	-
	Ground pressure	kgf/cm ²	(psi)	-	-	-	-	0.41	5.8	-	-	-	-
	Overall width	mm	(ft-in)	-	-	-	-	3190	10'6"	-	-	-	-
	Link quantity	EA		-		-		49		-		-	
HX220A HW	Operating weight	kg	(lb)	23650	52140	24120	53180	24400	53790	24690	54430	24410	53810
	Ground pressure	kgf/cm ²	(psi)	0.5	7.18	0.44	6.28	0.39	5.55	0.35	5	0.45	6.35
	Overall width	mm	(ft-in)	3395	11'2"	3495	11'6"	3595	11'10"	3695	12'2"	3495	11'6"
	Link quantity	EA		49		49		49		49		49	

2) SELECTION OF TRACK SHOE

Suitable track shoes should be selected according to operating conditions.

Method of selecting shoes

Confirm the category from the list of applications in **table 2**, then use **table 1** to select the shoe. Wide shoes (categories B and C) have limitations on applications. Before using wide shoes, check the precautions, then investigate and study the operating conditions to confirm if these shoes are suitable.

Select the narrowest shoe possible to meet the required flotation and ground pressure. Application of wider shoes than recommendations will cause unexpected problem such as bending of shoes, crack of link, breakage of pin, loosening of shoe bolts and the other various problems.

Table 1

Track shoe	Specification	Category
600 mm triple grouser	Standard	A
700 mm triple grouser	Option	B
700 mm double grouser	Option	B
800 mm triple grouser	Option	C
800 mm triple grouser (long reach)	Standard	C
900 mm triple grouser	Option	C

Table 2

Category	Applications	Precautions
A	Rocky ground, river beds, normal soil	<ul style="list-style-type: none">· Travel at low speed on rough ground with large obstacles such as boulders or fallen trees or a wide range of general civil engineering work
B	Normal soil, soft ground	<ul style="list-style-type: none">· These shoes cannot be used on rough ground with large obstacles such as boulders or fallen trees· Travel at high speed only on flat ground· Travel slowly at low speed if it is impossible to avoid going over obstacles
C	Extremely soft ground (swampy ground)	<ul style="list-style-type: none">· Use the shoes only in the conditions that the machine sinks and it is impossible to use the shoes of category A or B· These shoes cannot be used on rough ground with large obstacles such as boulders or fallen trees· Travel at high speed only on flat ground· Travel slowly at low speed if it is impossible to avoid going over obstacles

8. SPECIFICATIONS FOR MAJOR COMPONENTS

1) ENGINE

Item	Specification
Maker / Model	CUMMINS / B6.7
Type	4-cycle, turbocharged, charge air cooled, electronic controlled diesel engine
Cooling method	Water cooled
Number of cylinders and arrangement	6 cylinders, in-line
Firing order	1-5-3-6-2-4
Combustion chamber type	Direct injection type
Cylinder bore × stroke	107 × 124 mm (4.21" × 4.88")
Displacement	6.7 ℓ (408 cu in)
Compression ratio	17.3 : 1
Gross power	173 Hp (129 kW) at 2200 rpm
Net power	170 Hp (127 kW) at 2200 rpm
Max. power	195 Hp (145 kW) at 2000 rpm
Peak Torque	881 N · m (650 lb · ft) at 1,300 rpm
Engine oil quantity	23.1 ℓ (6.1 U.S. gal)
Wet weight or Dry weight	583 kg (1,285 lb)
Starter motor	24 V-4.8 kW
Alternator	24 V-95 A

2) MAIN PUMP

Item	Specification
Type	Variable displacement tandem axis piston pumps
Capacity	2 × 130 cc/rev
Maximum pressure	350 kgf/cm ² (4980 psi) [380 kgf/cm ² (5400 psi)]
Rated oil flow	2 × 221 ℓ /min (58.4 U.S. gpm / 48.6 U.K. gpm)
Rated speed	1700 rpm

[] : Power boost

3) GEAR PUMP

Item	Specification
Type	Fixed displacement gear pump single stage
Capacity	10 cc/rev
Maximum pressure	40 kgf/cm ² (570 psi)
Rated oil flow	17 ℓ /min (4.5 U.S. gpm/3.7 U.K. gpm)

4) MAIN CONTROL VALVE

Item	Specification	
Type	9 spools two-block	
Operating method	Hydraulic pilot system	
Main relief valve pressure	350 kgf/cm ² (4980 psi) [380 kgf/cm ² (5400 psi)] *1 350 kgf/cm ² (4980 psi) [Not applied power boost]	
Port relief valve pressure	Boom	400 kgf/cm ² (5690 psi)
	Arm	400 kgf/cm ² (5690 psi), *1 300 kgf/cm ² (4270 psi)
	Bucket	400 kgf/cm ² (5690 psi), *1 280 kgf/cm ² (3980 psi)

[] : Power boost *1 : Long reach only

5) SWING MOTOR

Item	Specification
Type	Axial piston motor
Capacity	142.8 cc/rev
Relief pressure	290 kgf/cm ² (4125 psi)
Braking system	Automatic, spring applied hydraulic released
Braking torque	1183 kgf · m (8560 lbf · ft) over
Brake release pressure	20.9 kgf/cm ² (297 psi) over
Reduction gear type	2 - stage planetary

6) TRAVEL MOTOR

Item	Specification	
	HX220A L/LR	HX220A HW
Type	Variable displacement axial piston motor	
Capacity	171.2/108.5 cc/rev	182.4/105.4 cc/rev
Relief pressure	350 kgf/cm ² (4980 psi)	
Braking system	Automatic, spring applied hydraulic released	
Braking torque	3028 kgf · m (21900 lbf · ft)	3180 kgf · m (23000 lbf · ft)
Brake release pressure	13.5 kgf/cm ² (192 psi)	14.2 kgf/cm ² (202 psi)
Reduction gear type	2-stage planetary	

7) CYLINDER

Item		Specification
Boom cylinder	Bore dia × Stroke	Ø120 × 1290 mm
	Cushion	Extend only
Arm cylinder	Bore dia × Stroke	Ø140 × 1510 mm
	Cushion	Extend and retract
Arm cylinder (2-piece boom)	Bore dia × Stroke	Ø140 × 1510 mm
	Cushion	Extend and retract
Adjust cylinder (2-piece boom)	Bore dia × Stroke	Ø160 × 1060 mm
	Cushion	NA
Bucket cylinder	Bore dia × Stroke	Ø120 × 1055 mm
	Cushion	Extend only
Bucket cylinder (Long reach)	Bore dia × Stroke	Ø100 × 870 mm
	Cushion	Extend only

- ※ Discoloration of cylinder rod can occur when the friction reduction additive of lubrication oil spreads on the rod surface.
- ※ Discoloration does not cause any harmful effect on the cylinder performance.

9. RECOMMENDED OILS

HYUNDAI genuine lubricating oils have been developed to offer the best performance and service life for your equipment. These oils have been tested according to the specifications of HYUNDAI and, therefore, will meet the highest safety and quality requirements.

We recommend that you use only HYUNDAI genuine lubricating oils and grease officially approved by HYUNDAI.

Service point	Kind of fluid	Capacity ℓ (U.S. gal)	Ambient temperature °C (°F)										
			-50 (-58)	-30 (-22)	-20 (-4)	-10 (14)	0 (32)	10 (50)	20 (68)	30 (86)	40 (104)		
Engine oil pan	Engine oil	23.1 (6.1)	★SAE 0W-40										
			SAE 5W-40										
			SAE 15W-40										
DEF/ AdBlue® tank	Mixture of urea and deionized water	48 (12.6)	ISO 22241, High-purity urea + deionized water (32.5:67.5)										
Swing drive	Gear oil	6.2 (1.6)	★SAE 75W-90										
Final drive		4.5×2 (1.2×2)	SAE 80W-90										
Hydraulic tank	Hydraulic oil	Tank 160 (42.3)	★ISO VG 15										
			ISO VG 32										
		System 275 (72.6)	ISO VG 46, HBHO VG 46★ ³										
			ISO VG 68										
Fuel tank	Diesel fuel★ ¹	400 (106)	★ASTM D975 NO.1										
			ASTM D975 NO.2										
Fitting (grease nipple)	Grease	As required	★NLGI NO.1										
			NLGI NO.2										
Radiator (reservoir tank)	Mixture of antifreeze and soft water★ ²	40 (10.6)	Ethylene glycol base permanent type (50 : 50)										
			★Ethylene glycol base permanent type (60 : 40)										

SAE : Society of Automotive Engineers

API : American Petroleum Institute

ISO : International Organization for Standardization

NLGI : National Lubricating Grease Institute

ASTM : American Society of Testing and Material

DEF : Diesel Exhaust Fluid, DEF compatible with AdBlue®

★ : Cold region (Russia, CIS, Mongolia)

★¹ : Ultra low sulfur diesel
- sulfur content ≤ 15 ppm

★² : Soft water
City water or distilled water

★³ : Hyundai Bio Hydraulic Oil

※ Using any lubricating oils other than HYUNDAI genuine products may lead to a deterioration of performance and cause damage to major components.

※ Do not mix HYUNDAI genuine oil with any other lubricating oil as it may result in damage to the systems of major components.

※ Do not use any engine oil other than that specified above, as it may clog the diesel particulate filter(DPF).

※ For HYUNDAI genuine lubricating oils and grease for use in regions with extremely low temperatures, please contact your local Hyundai dealer.

HYDRAULIC BREAKER AND QUICK CLAMP

1. SELECTING HYDRAULIC BREAKER

- 1) Become familiar with the manual and select breakers suitable to machine specifications.
- 2) Make careful selection in consideration of oil quantity, pressure and striking force, to enable satisfied performance.
- 3) When apply a breaker to the machine, consult your local dealer of Hyundai for further explanation.

2. CIRCUIT CONFIGURATION

- 1) As for breaker oil pressure line, use extra spool of main control valve.
- 2) Set proper breaker pressure on load relief valve.
※ **The initial setting pressure of load relief valve for breaker is 200 bar.**
- 3) The pressure of the HX220A L system is 350 kgf/cm² (4980 psi).

4) Adjusting oil quantity

- (1) Use the breaker mode from work tool of cluster.
Use select switch to control the oil flow quantity.
· Setting oil quantity (170 lpm)

Flow set

- Max flow : Set the maximum flow for the attachment.
- (2) If the quantity of hydraulic oil is not controlled properly, it causes short lifecycle of the breaker and the machine by increased breaking force and count.

- 5) The accumulator should be used to the breaker charging and return line.
If the accumulator is not used, it can cause damage as the input wave is delivered.
※ **Keep the pressure pulsation of pump below 60 kgf/cm² (853 psi) by installing the accumulator.**
- 6) Do not connect the breaker return line to the main control, but connect to the return line in front of oil cooler.
- 7) Do not connect the breaker return line to drain lines, such as swing motor, travel motor or pump, otherwise they will be damaged.
- 8) One spool of the main control valve should be connected to the tank.
- 9) Select the size of pipe required considering the amount of back pressure.
- 10) Shimless tube should be used for the piping. The hose and seal should be Hyundai genuine parts.
- 11) Weld the bracket for pipe clamp to prevent damage caused by vibration.

Oil quantity setting



3. MAINTENANCE

1) MAINTENANCE OF HYDRAULIC OIL AND FILTER

- (1) A machine with hydraulic breaker can cause the hydraulic oil to become severely contaminated.
- (2) Therefore machine may go down if not maintained properly.
- (3) Inspect and maintain hydraulic oil, hydraulic oil return filter, pilot line filter element and drain filter.

2) RELEASING THE PRESSURE IN BREAKER CIRCUIT

When breaker operating is finished, stop engine and push pedal or switch for breaker to release pressure in breaker circuit.

If you allow pressure to remain on the system, the lifetime of the diaphragm in the accumulator will be shortened.

- 3) Be careful to prevent contamination by dust, sand etc.
If such pollution becomes mixed into the oil, the pump's moving parts will wear abnormally, shorten lifetime and become damaged. This could also contaminate the entire hydraulic system.
- 4) When operating breaker, bolts and nuts of main equipment may be loosened by vibration. Therefore, it must be inspected periodically.

Service interval unit : hours

Attachment	Operating rate	Hydraulic oil	Filter element
Breaker	100 %	600* ¹	200
		1000* ²	

*¹: Conventional hydraulic oil

*²: Hyundai genuine long life hydraulic oil

● Replace following filter at same time

- Hydraulic return oil filter : 1 EA
- Pilot line filter element: 1 EA
- Drain filter : 1 EA

Hyd oil change guide for hydraulic breaker

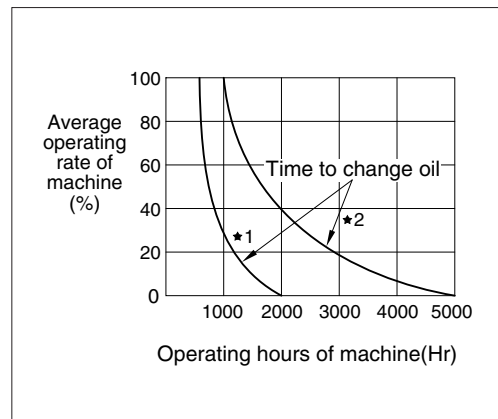

*¹: Conventional hydraulic oil

*²: Hyundai genuine long life hydraulic oil

4. PRECAUTIONS WHILE OPERATING THE BREAKER

1) DO NOT BREAK ROCK WHILE LOWERING

As the breaker is heavy in comparison with bucket, it must be operated slowly.

If breaker is rapidly pushed down, working device may be damaged.

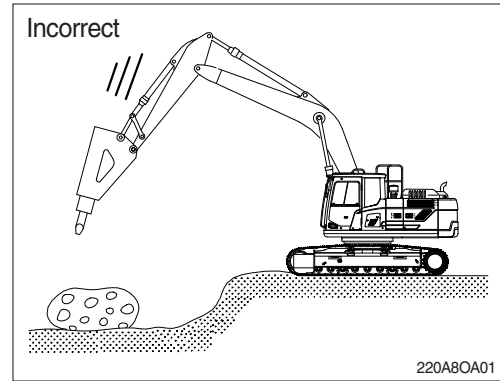

2) DO NOT USE BREAKER TO CARRY BROKEN STONE OR ROCK BY SWING OPERATING

This may damage the operation device and swing system.

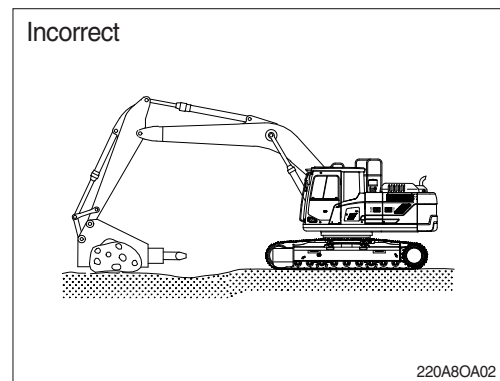

3) OPERATE BREAKER WITH A GAP IN EXCESS OF 100 mm (4 inches) FROM THE END OF THE STROKE TIP

If breaker is operated with the end tip, the cylinder may be damaged.

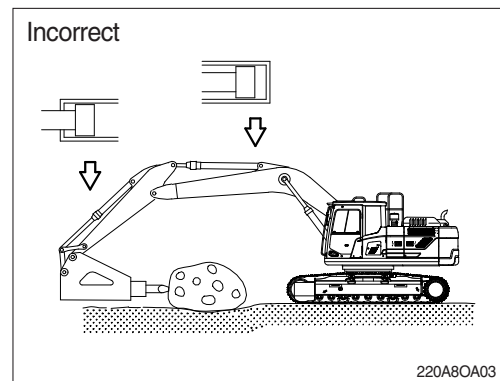

4) IF THE HYDRAULIC HOSES VIBRATE EXCESSIVELY

If the machine is used in this condition continuously this will effect the machine severely such as loosening bolts, oil leakage, damage of pump pipes etc.

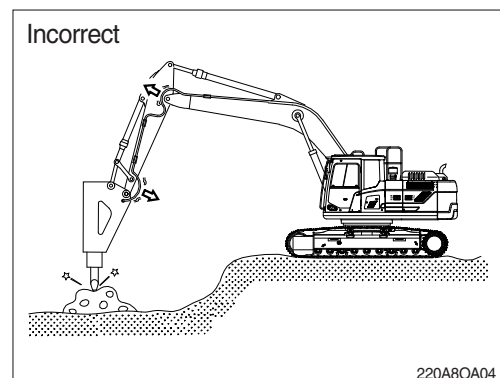

5) DO NOT CONTINUE TO USE BREAKER OVER ONE MINUTE IN THE SAME POSITION

This will increase the temperature of the oil, and cause problems with the accumulator and seals.

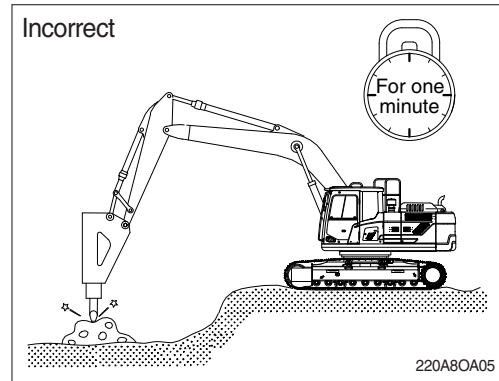

6) DO NOT MOVE MACHINE OR BREAKER WHILE STRIKING

Do not move hammer while striking.
This will cause damage to the working device and the swing system.

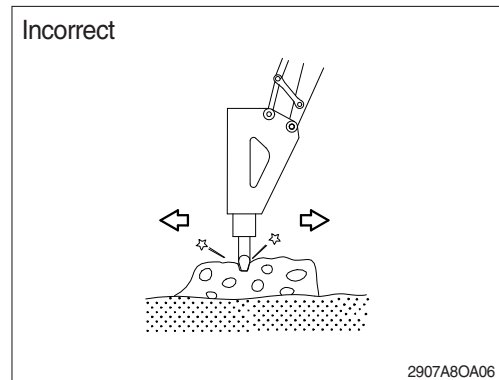

7) DO NOT WORK WHILE IN A SWING STATE

Do not work while swinging the upper structure. It cause oil leakage of the bend in the track shoe and rollers.

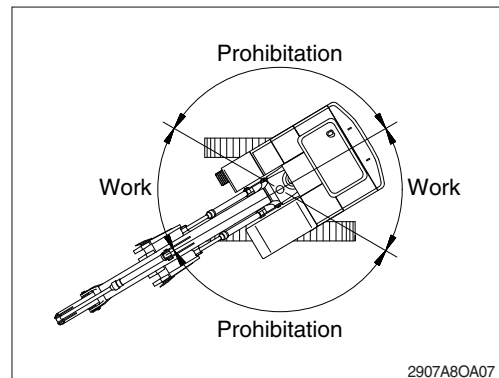

8) TAKE CARE OF CHISEL AND BOOM INTERFACE

Be aware of clearance between breaker tip and the underside of boom as shown in the illustration.

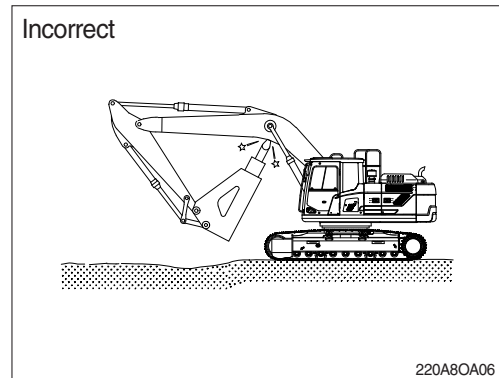

5. QUICK CLAMP

1) FIXING BUCKET WITH QUICK CLAMP

- (1) Before fixing bucket, remove safety pin of the moving hook.
- (2) Pulling safety button, press the quick clamp switch to unlock position. Then, the moving hook is placed in the release position.

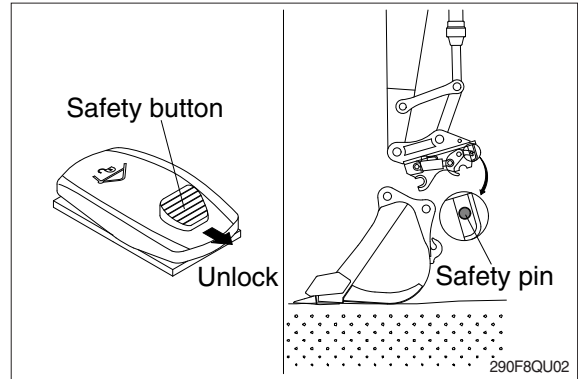

- (3) Aligning the arm and bucket, insert static hook of quick clamp to the bucket pin.

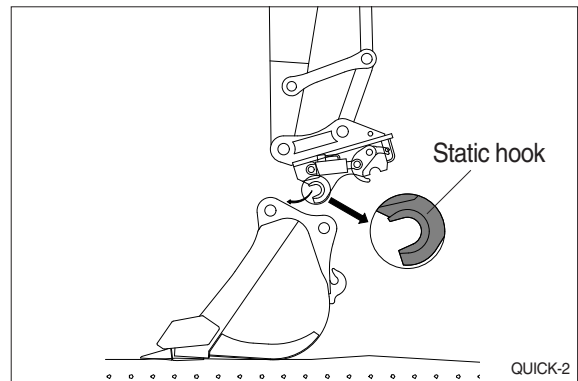

- (4) Operate RCV lever to bucket-in position. Then, the moving hook is coupled with the bucket link pin. Make sure that the moving hook is completely contacted with bucket link pin.

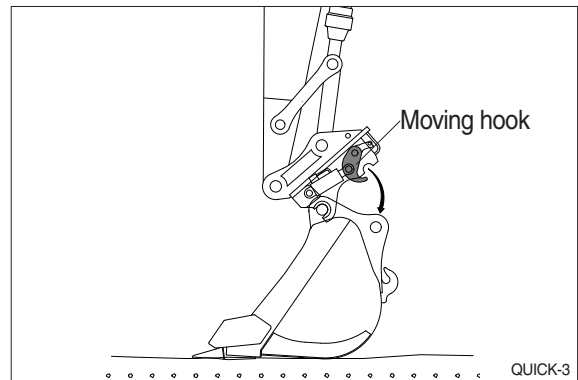

- (5) Push safety button to lock position. Operate RCV lever to bucket-in position.
※ **Be sure to check connection status between bucket pins and hooks of quick clamp.**

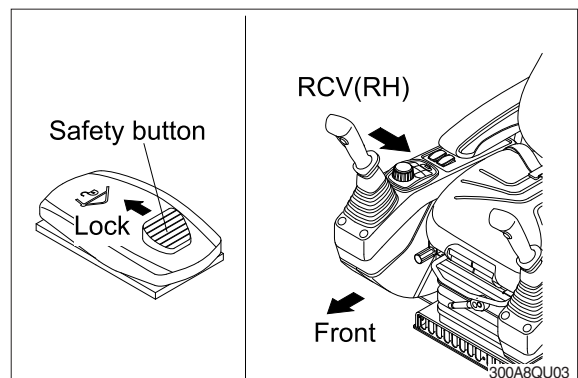

- (6) After checking the connection status between bucket pins and hooks of quick clamp, insert safety pin of moving hook to lock position.

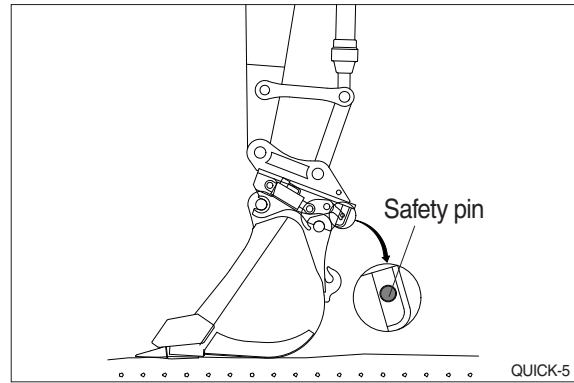

2) REMOVE BUCKET FROM QUICK CLAMP

Removing procedure is reverse of fixing.

3) PRECAUTION OF USING QUICK CLAMP

- ▲ When operating the machine with quick clamp, confirm that the quick clamp switch is in the LOCK position and safety pin of moving hook is inserted. Operating the machine with quick clamp switch unlocked and without safety pin of moving hook can cause the bucket to drop off and could result in personal injury, death, machine damage or property damage.

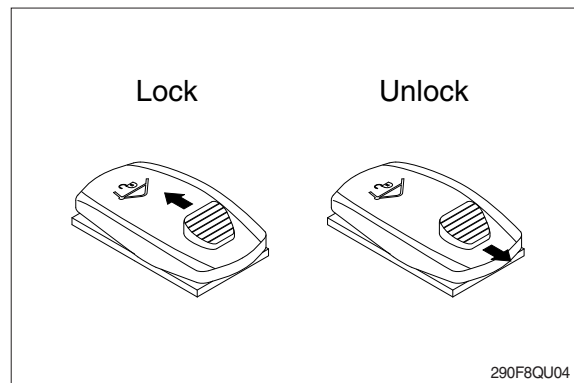

- ▲ Be careful of the operating the machine which is equipped with quick clamp. The bucket may hit cab, boom and boom cylinders when it reaches the vicinity of them as shown in the illustration.

HYUNDAI will not be responsible for any injury, death or damage in the event that the coupler, attachment and safety pin are not installed correctly.

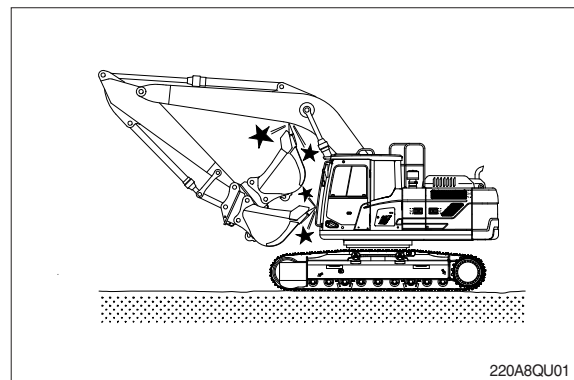

A	
AAVM	3-36
After engine start	2-5
Air breather element	4-42
Air cleaner filter	4-39
Air conditioner & heater	3-37
Air conditioner filter	4-54
Alternate exit	1-37
Attachment lowering	2-23
Auto safety lock	3-15
B	
Battery	4-51
Battery cable and connection	4-53
Before starting engine	2-2
Bluetooth	3-60
Boom lowering	2-23
Bucket clearance adjustment	4-49
Bucket replacement	4-47
Bucket selection guide	7-23
Bucket tooth replacement	4-48
C	
Cab air filter	4-54
Cab device	3-1
Changing machine control pattern	2-26
Charge air cooler	4-25
Charge air piping	4-30
Cigar lighter	3-49
Cluster	3-2
Cooling fan	4-26
D	
DEF/AdBlue® supply module filter	4-33
DEF/AdBlue® tank	4-31
DEF/AdBlue® tank filter	4-32
Dimension and weight	5-2
DPF	4-34
Drain filter	4-42
E	
Emergency engine speed connector	3-79
Engine cleaning	4-34
Engine oil filter	4-20
Engine oil level	4-20
Engine starting & stop	2-3
Engine starting by booster	4-52
Engine stop	2-6
Exhaust system cleaning	2-28
F	
Fan belt	4-26
Fuel pre-filter	4-29
Fuel filter	4-30
Fuel leakage	4-31
Fuel system bleeding	4-30
Fuel tank	4-28
Fuse & relay box	3-78
G	
Gauge	3-3
Getting on and off	1-19
H	
HEST.....	3-10
Hydraulic breaker	8-1
Hydraulic oil changing	4-41
Hydraulic oil filling	4-3
Hydraulic oil level	4-40
Hydraulic oil return filter	4-42
J	
Jog dial module	3-66
L	
LCD	3-2
Levers & pedals	3-46
Lifting capacities	7-11
Lubricant specification.....	7-29
M	
Maintenance check list	4-11
Major component	7-1
MCU (Machine Control Unit)	3-78
Mode selection system	2-7
Monitor panel	3-2
Multimodal dial	3-66
N	
New machine operation	2-1
O	
Oil cooler	4-25
Operating pattern	2-26

Overhead set	4-36	Track adjustment	4-46
Owner menu editing	3-31	Track shoe selection	7-24
P		Transportation	5-1
Pedals	3-47	Travel reduction gear oil	4-45
Periodical replacement parts	4-5	Traveling machine	2-13
Pilot line filter element	4-43	Troubleshooting guide	6-1
Pin & bushing lubrication	4-50	U	
Pilot lamps	3-13	Undercarriage	7-24
Q		USB port	3-66
Quick clamp	8-6	V	
R		Vibration damper	4-35
Radiator coolant	4-22	W	
Radiator flushing	4-22	Warming up operation	2-5
Radio & USB player	3-50	Warning lamps	3-6
RCV lever lubricate	4-45	Weight	7-10
Recommended oils	4-10,7-29	Welding repair	4-53
Relieving pressure	4-3	Windshield	3-80
RCV lever operating pattern	2-26	Working device operation	2-12
S		Working method	2-16
Safety labels	1-31	Working range	7-8
Safety instructions	1-2		
Safety parts	4-5		
Seat	3-70		
Seat belt	3-77		
Service meter	3-79		
Service socket	3-79		
Smart key tag	3-41		
Specification for major component	7-26		
Specification	7-2		
Start switch	3-41		
Storage	2-24		
Suction strainer	4-41		
Surge tank	4-22		
Swing bearing grease	4-43		
Swing gear & pinion grease	4-44		
Swing reduction gear oil	4-43		
Switch panel	3-41		
Switches	3-16,3-41		
T			
Torques-major component	4-8		
Torques-fastener	4-6		
Towing machine	2-15		