

CONTENTS

EC declaration of conformity	0-1	9. Operation in the special work sites	4-23
Foreword	0-2	10. Storage	4-25
Emission-related components warranty (USA and CANADA only)	0-2-1	11. Exhaust system cleaning	4-27
Before servicing this machine	0-3	12. Open the engine hood	4-28
Table to enter S/No and distribution	0-4	13. Attachment manually lowering	4-31
EC regulation approved	0-5		
Safety labels	0-6	5. TRANSPORTATION	
Machine data plate	0-17	1. Road traveling	5-1
Guide (direction, S/No, symbol)	0-18	2. Preparation for transportation	5-2
		3. Loading the machine	5-3
1. SAFETY HINTS		4. Fixing the machine	5-4
1. California proposition 65	1-1	5. Loading and unloading by crane	5-6
2. Safety rules	1-2	6. Towing the machine	5-7
		6. MAINTENANCE	
2. SPECIFICATIONS		1. Instructions	6-1
1. Major components	2-1	2. Tightening torque	6-5
2. Specifications	2-2	3. Spec of fuel, coolant and lubricants	6-8
3. Weight	2-6	4. Maintenance check list	6-10
4. Specification for major components	2-7	5. Maintenance chart	6-13
		6. Service instruction	6-15
3. CONTROL DEVICES		7. Electrical system	6-50
1. Cab devices	3-1	8. Air conditioner and heater	6-53
2. Cluster	3-2		
3. Monitors	3-13	7. TROUBLESHOOTING GUIDE	
4. Switches	3-44	1. Engine	7-1
5. Control device	3-49	2. Electrical system	7-2
6. Air conditioner and heater	3-53	3. Power train system	7-3
7. Others	3-56	4. Hydraulic system	7-4
		8. OTHERS	
4. OPERATION		1. Central grease lubrication system	8-1
1. Suggestion for new machine	4-1	2. Quick coupler	8-9
2. Check before starting the engine	4-2		
3. Starting and stop the engine	4-3	INDEX	9-1
4. Warming-up operation	4-8		
5. Operation of the working device	4-9		
6. Traveling of the machine	4-10		
7. Efficient working method	4-15		
8. Adjustment of the work equipment	4-22		

EC Declaration of Conformity
(Original instruction)

This declaration of conformity is issued under the sole responsibility of manufacturer:

HYUNDAI CONSTRUCTION EQUIPMENT CO., LTD.
12th Fl., Hyundai Bldg. 75, Yulgok-ro, Jongno-gu,
Seoul 03058, Korea

Hyundai Construction Equipment Europe N.V located at Hyundailaan 4, 3980 Tessenderlo, Belgium, as authorized representative in the European Community is authorized to compile the technical construction file and declares that the product:

Type: *****
Model: *****
Serial number (PIN): *****

is in conformity with the relevant provisions of the Community harmonization legislation:

2006/42/EC - Machinery directive
2014/30/EU - Electromagnetic compatibility directive
2000/14/EC - Noise emission outdoor equipment directive
2002/44/EU - Exposure of workers to vibration risks directive
their amendments, and other applicable directives.

EMC (2014/30/EU)

Certificate number: *****
Date: DD/MM/YYYY
Notified body: *****

Noise levels (2000/14/EC)

Certificate number: *****
Date: DD/MM/YYYY
Conformity assessment proc.: Annex VIII Full Quality Assurance
Notified body: *****

Measured sound power level: nnn.n dB(A)
Guaranteed sound power level: nnn.n dB(A)

Engine information

Manufacturer : *****
Engine model name: *****
Type-approval number: *****
Stage (Regulation) : STAGE ** (**/**/**)
Gross Power (SAE J1995): ***kW / ****rpm
Net Power (SAE J1349): ***kW / ****rpm

Harmonized standards, other technical standards and specifications applied:

EN 474-1:2006+A*:**** (EMM - Safety - Part 1); EN 474-3:2006+A*:**** (EMM - Safety - Part 3); EN ISO 3471:2008 (EMM - ROPS: Lateral/Vertical/Longitudinal loads); EN ISO 3449:2008 (EMM - FOPS: Level II cabin); ISO 2631-1:1997 & ISO 2631-1:1997/Amd1 :2010 (Whole-body vibration); EN ISO 5349-1:2001 & EN ISO 5349-2:2001 & EN ISO 5349-2:2001/A1:2015 (Hand-arm vibration)

Managing Director
Place, date of issue: Tessenderlo Belgium, DD MM YYYY

FOREWORD

This manual contains a number of instructions and safety recommendations regarding driving, handling, lubrication, maintenance, inspection and adjustment of the machine.

The manual is to promote safety maintenance and enhance machine performance.

Keep this manual handy and have all personnel read it periodically.

If you sell the machine, be sure to give this manual to the new owners.

This machine complies with EC directive "2006/42/EC".

1. **Read** and **understand** this manual before operating the machine.

This operator's manual may contain attachments and optional equipment that are not available in your area. Please consult your local Hyundai distributor for those items you require.

Improper operation and maintenance of this machine can be hazardous and could result in serious injury or death.

Some actions involved in operation and maintenance of the machine can cause a serious accident, if they are not done in a manner described in this manual.

The procedures and precautions given in this manual apply only to intended uses of the machine. If you use your machine for any unintended uses that are not specifically prohibited, you must be sure that it is safe for you and others. In no event should you or others engage in prohibited uses of actions as described in this manual.

Some illustrations in this manual show details or attachments that can be different from your machine. Covers and guards might have been removed for illustrative purposes.

2. **Inspect** the jobsite and **follow** the safety recommendations in the **safety hints** section before operating the machine.

3. Use **genuine Hyundai spare parts** for the replacement of parts.

We expressly point out that Hyundai will not accept any responsibility for defects resulting from non-genuine parts or non workmanlike repair.

In such cases Hyundai cannot assume liability for any damage.

Continuing improvements in the design of this machine can lead to changes in detail which may not be reflected in this manual. Consult Hyundai or your Hyundai distributor for the latest available information for your machine or for questions regarding information in this manual.

EMISSION-RELATED COMPONENTS WARRANTY (USA AND CANADA ONLY)

Hyundai shall have obligation under the EPA (Environmental Protection Agency) regulation of warranty about Emission-related components. This warranty shall exist for 3,000 hours or five years, whichever occurs first.

Naturally, this warranty does not cover to damage arising from accident, misuse or negligence, use of non-Hyundai parts, or from alterations not authorized by Hyundai.

※ Emission-related components according to the EPA regulation.

1. Air-induction system.
2. Fuel system.
3. Ignition system.
4. Exhaust gas recirculation systems.
5. After treatment devices.
6. Crankcase ventilation valves.
7. Sensors.
8. Electronic control units.

BEFORE SERVICING THIS MACHINE

It is the responsibility of the owner and all service and maintenance personnel to avoid accidents and serious injury by keeping this machine properly maintained.

It also is the responsibility of the owner and all service and maintenance personnel to avoid accidents and serious injury while servicing the machine.

No one should service or attempt to repair this machine without proper training and supervision.

All service and maintenance personnel should be thoroughly familiar with the procedures and precautions contained in this manual.

All personnel also must be aware of any federal, state, provincial or local laws or regulations covering the use and service of construction equipment.

The procedures in this manual do not supersede any requirements imposed by federal, state, provincial or local laws.

Hyundai can not anticipate every possible circumstance or environment in which this machine may be used and serviced.

All personnel must remain alert to potential hazards.

Work within your level of training and skill.

Ask your supervisor if you are uncertain about a particular task. Do not try to do too much too fast.

Use your common sense.

※ How to adjust the language of monitor

User can select preferable language and all displays are changed the selected language.

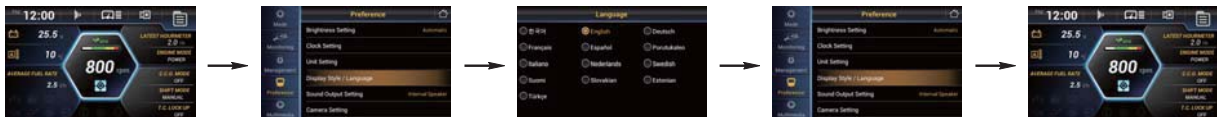

※ Please refer to the page 3-34 for the monitor.

TABLE TO ENTER SERIAL NO. AND DISTRIBUTOR

Machine Serial No.	
Engine Serial No.	
Manufacturing year	
Manufacturer Address	Hyundai Construction Equipment co., Ltd. 12th, Fl., Hyundai Bldg. 75, Yulgok-ro, Jongno-Gu, Seoul, 03058, Korea
Distributor for U.S.A Address	Hyundai Construction Equipment U.S.A, Inc 6100 Atlantic Boulevard Norcross GA 30071 U.S.A
Distributor for Europe Address	Hyundai Construction Equipment Europe N. V. Hyundailaan 4 3980 Tessenderlo Belgium
Dealer Address	

EC REGULATION APPROVED

- Noise level (EN474-1 : 2006 and 2000/14/EC) are as followings.
LWA : 105 dB (EU only)
LPA : 68 dB
- The value of vibrations transmitted by the operator's seat are lower than standard value of (EN474-1 : 2006 and 2002/44/EC)



SAFETY LABELS

1. LOCATION

Always keep these labels clean. If they are lost or damaged, attach them again or replace them with a new label.

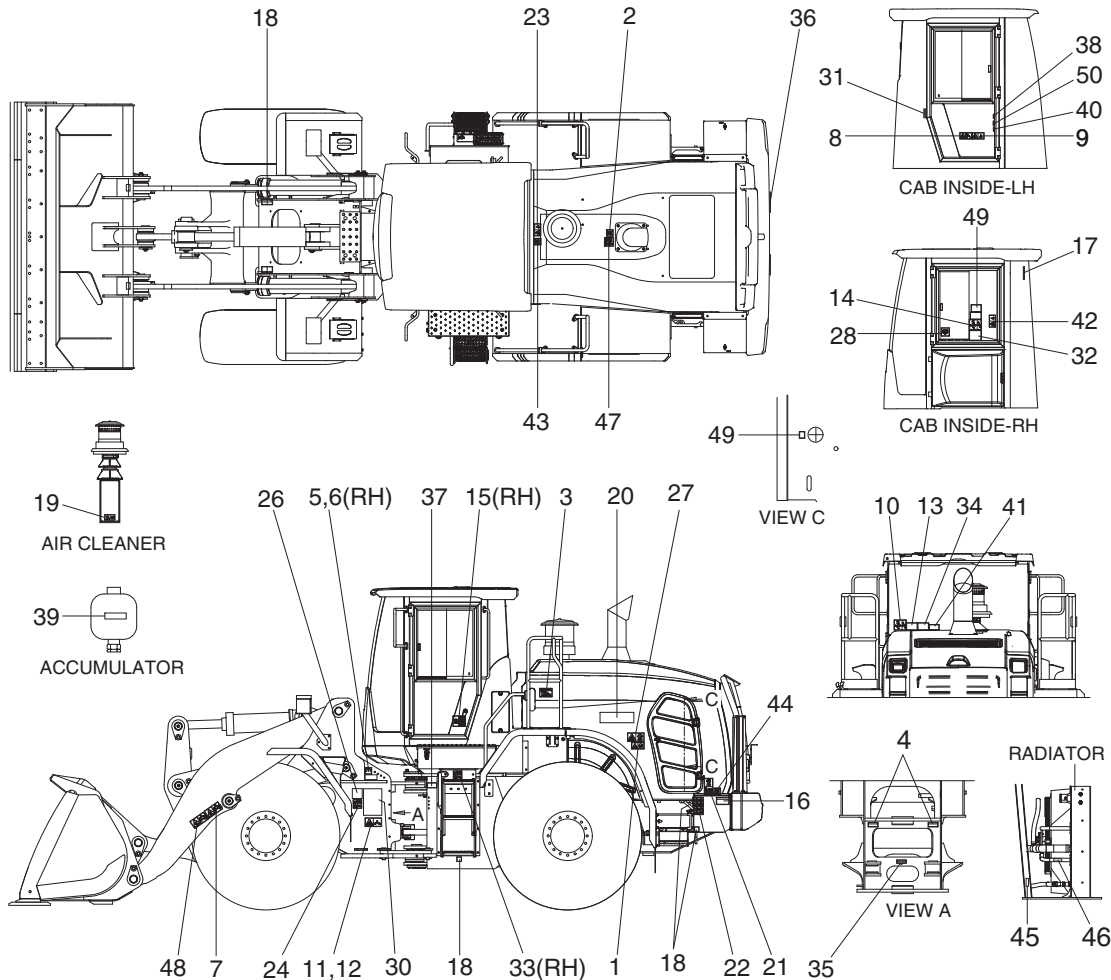

1	Start motor	18	Lift & tie	35	Grease (center)
2	Turbocharger cover	19	Air cleaner	36	Keep clear/Reflect
3	Hyd oil level	20	Bio oil	37	Name plate
4	Ride control (option)	21	Fueling	38	ROPS plate
5	Grease (A)	22	Battery accident	39	Accumulator
6	Grease (B)	23	Hyd oil lub	40	Joystick steering (option)
7	Bucket stopper	24	High pressure hose	41	Caution (water separator, turbocharger)
8	Max h/reach	26	Manual lowering valve	42,43	Tilt handle, Fuel cut off
9	Roll over	27	Engine door shearing	44	Ultra low sulfur diesel
10	ROPS cab	28	Alternate exit	45	Refrigerant
11,12	Steering warning-LH/RH	29	Low emission engine	46	Use handrail
13	Engine start caution	30	Service instruction	47	No step
14	Control ideogram	31	Fire extinguisher	48	Quick coupler (option)
15	Air conditioner filter	32	Start procedure	49	Emergency fire hole
16	Electric welding	33	Diesel exhaust fluid	50	Engine name plate
17	Hammer	34	Specification sheet		

2. DESCRIPTION

There are several specific warning labels on this machine please become familiarized with all warning labels. Replace any safety label that is damaged, or missing. If a safety label is attached to a part that is replaced, install a safety label on the replacement part.

1) START MOTOR (item 1)

This warning label is positioned on the left side of the engine hood.

- ▲ Start the engine only from the operator's compartment. Never short across the starter terminals or across the batteries. Shorting could bypass the engine neutral start system. Shorting could also damage the electrical system.

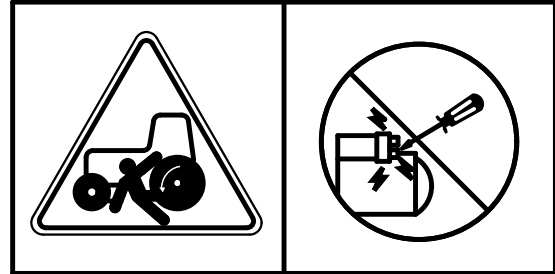

77070FW05

2) TURBOCHARGER COVER (item 2)

This warning label is positioned on the turbocharger cover.

- ▲ Do not touch turbocharger or it may cause severe burn. When the engine is running or immediately after engine shut down.



21070FW02

3) HYDRAULIC OIL LEVEL (item 3)

This warning label is positioned on the left side of hydraulic oil tank.

- ▲ Place the bucket on the ground whenever servicing the hydraulic system.
- ※ Check oil level on the level gauge.
- ※ Refill the recommended hydraulic oil up to specified level if necessary.

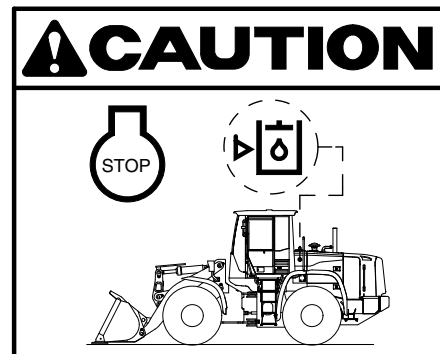

7609A0FW06

4) RIDE CONTROL (item 4)

This warning label is positioned on the front frame.

Before checking the boom operation system,

1. Bucket should be laid on the ground.
2. Turn start switch to "ON" position and press the button on monitor to operate ride control function.
3. Depressurize boom head by joystick.
(boom down or floating)

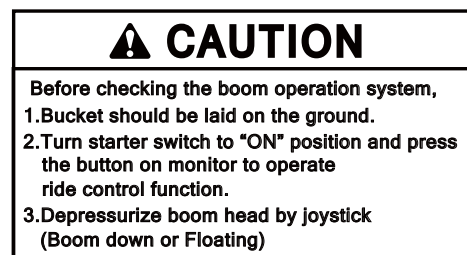

970A0FW90

5) **BUCKET STOPPER** (item 7)

This warning label is positioned on the middle of the boom.

- ⚠ **When working under or around the bucket or linkage, with bucket raised, proper support must be provided for the bucket and/or the linkage.**

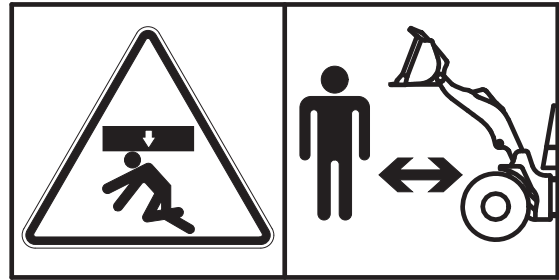

7803AFW05

6) **MAX HEIGHT** (item 8)

This warning label is positioned on the left side window of the cab.

- ⚠ **Serious injury or death can result from contact with electric lines.**
An electric shock being received by merely coming into the vicinity of an electric lines, the minimum distance should be kept considering the supply voltage as page 1-6.

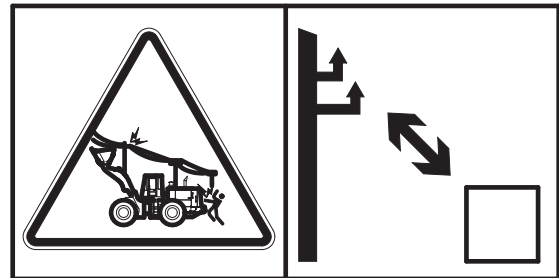

7803AFW16

7) **ROLL OVER** (item 9)

This warning label is positioned on the left side window of the cab.

- ⚠ **Structural damage, an overturn, modification, alternation, or improper repair can impair this structure's protection capability thereby voiding this certification.**
- ⚠ **Always use seat belt when operating your machine. Always check the condition of the seat belt and the condition of the mounting hardware before you operate the machine.**



77070FW14

8) **STEERING WARNING** (item 11, 12)

The warning label is positioned on the both side of the front frame.

- ⚠ **No clearance for person in this area when machine turns.**
- ⚠ **Severe injury or death from crushing could occur.**

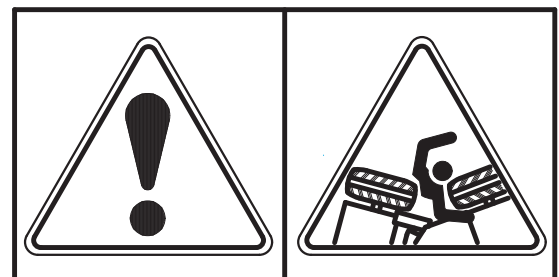

77070FW07

9) ENGINE START CAUTION (item 13)

This warning label is positioned on the rear side window of the cab.

▲ Study the operator's manual before starting and operating machine.

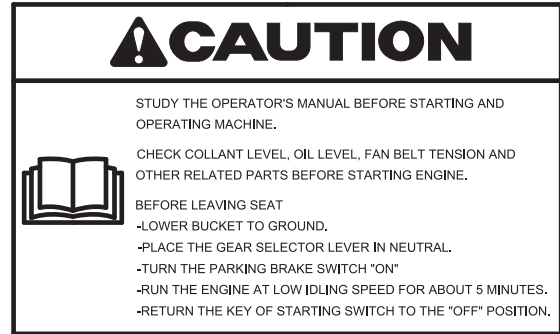

77070FW08

10) CONTROL IDEOGRAM (item 14)

This warning label is positioned on the right side window of the cab.

▲ Confirm the operation of control lever and working device before operating the machine.

※ Refer to the page 4-9 for details.

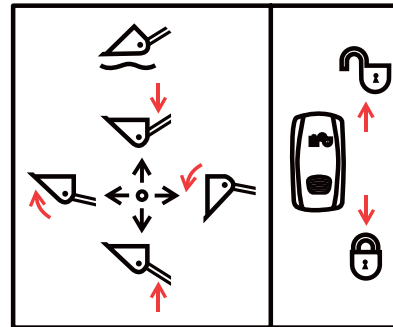

74090FW04

11) AIR CONDITIONER FILTER (item 15)

This warning label is positioned on the air conditioner filter.

※ Periodic and proper inspection, cleaning and change of filter prolong air conditioner life time and maintain good performance.

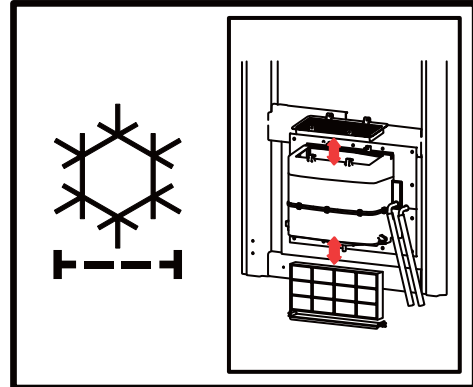

760F0FW10

12) ELECTRIC WELDING (item 16)

This warning label is positioned on the side of the battery box.

▲ Before carrying out any electric welding on this machine

- Pull the connectors out of all electronic control units.
- Connect the ground lead of the welding equipment as close to the welding point as possible.

※ Refer to the page 6-48 for details.

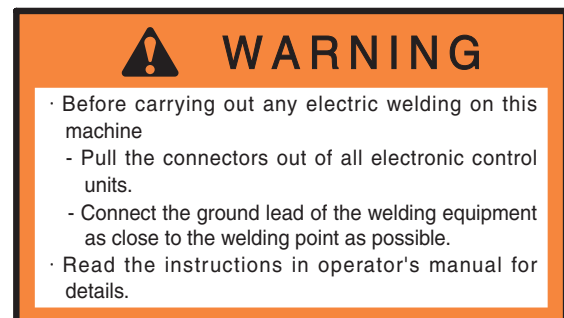

7803AFW20

13) LIFT & TIE (item 18)

This label is positioned on the both side of the front and rear frame.

- Lifting point

In order to lift the machine, attach the lifting devices to the lifting points.

- Tying point

In order to tie down the machine, attach the tie-downs to the tying points.

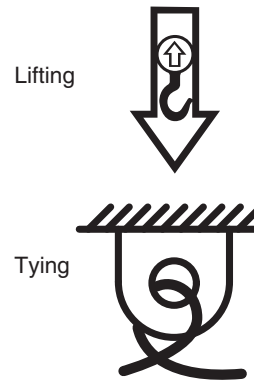

75790FW04

14) AIR CLEANER (item 19)

The warning label is positioned on the air cleaner.

⚠ Periodic and proper inspection, cleaning and change of elements prolong engine life time and maintain the good performance of engine.

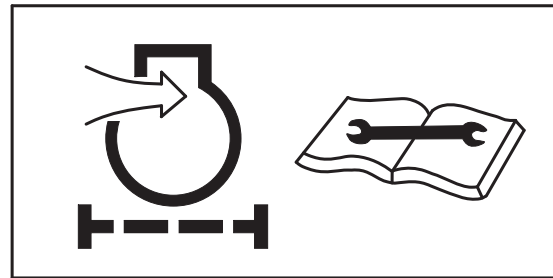

21070FW01

15) BIO OIL (item 20)

This warning label is positioned on the right side of the engine hood.

⚠ Do not mix with other bio-oil.



960A0FW11

16) FUELING (item 21)

This warning label is positioned on the left side of fuel filler neck.

⚠ Stop the engine when refueling. All lights or flames shall be kept at a safe distance while refueling.

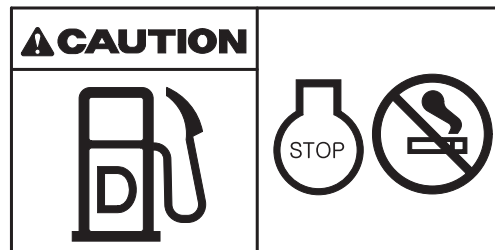

21070FW04

17) BATTERY ACCIDENT (item 22)

This warning label is positioned on the battery box.

- ⚠ **Electrolyte containing sulfuric acid cause severe burns. Avoid being in contact with skin, eyes or clothes. In the event of accident flush with sufficient water, call a physician immediately.**
- ※ **Maintain the electrolyte at the recommended level. Add distilled water to the battery only when starting up, never when shutting down.**
With electrolyte at proper level, less space may cause the gases to be accumulated in the battery.
- ⚠ **Extinguish all smoking materials and open flames before checking the battery.**
- ⚠ **Do not use matches, lighters or torches as a light source near the battery for the probable presence of explosive gas.**
- ⚠ **Do not allow unauthorized personnel to change the battery or to use booster cables.**
- ⚠ **For safety from electric shock, do not battery terminal with a wet hand.**

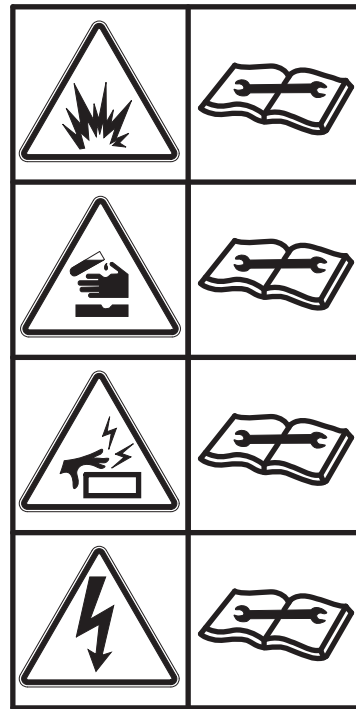

7579A0FW30

18) HYDRAULIC OIL LUB (item 23)

This warning label is positioned on the top of the hydraulic oil tank.

- ※ **Do not mix with different brand oils.**
- ⚠ **Never open the filler cap while engine running or at high coolant temperature.**
- ⚠ **Loosen the cap slowly and release internal pressure completely.**



14070FW08

19) **HIGH PRESSURE HOSE** (item 24)

This warning label is positioned on the left side of the front frame.

- ▲ Escaping fluid under pressure can penetrate the skin causing serious injury.
- ▲ Avoid the hazard by relieving pressure before disconnecting hydraulic lines or other lines.
- ※ See the maintenance section for details.



14070FW29

20) **MANUAL LOWERING VALVE** (item 26)

The warning label is positioned on the left side of the front frame.

- ▲ Be sure no one is under or near the attachment before lowering the boom.
- ※ Refer to the page 4-30.

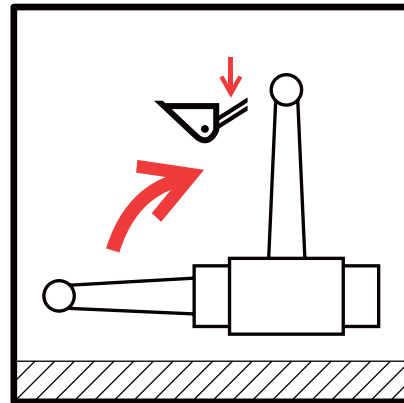

760F0FW12

21) **ENGINE DOOR SHEARING** (item 27)

This warning label is positioned on the left side of the engine side door.

- ▲ Don't open the engine door during the engine's running. Stay clear of rotating parts.
- ▲ Don't touch exhaust pipe or it may cause severe burn.

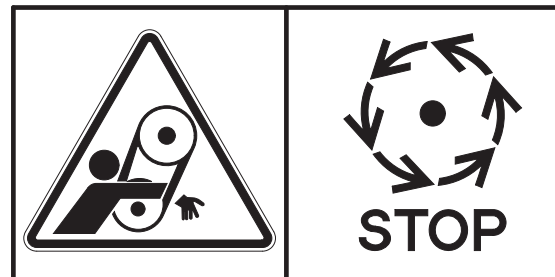

21070FW15

22) **ALTERNATE EXIT** (item 28)

This warning label is positioned on the right side window of the cab.

- ※ The right window serve as an alternate exit.
- ※ Refer to the page 3-60.

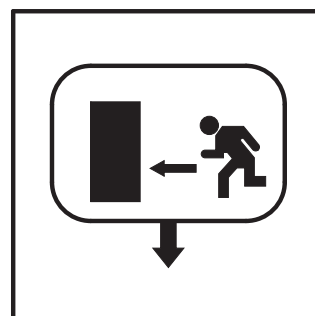

77070FW12

23) START PROCEDURE (item 32)

This warning label is positioned on the right side window of the cab.

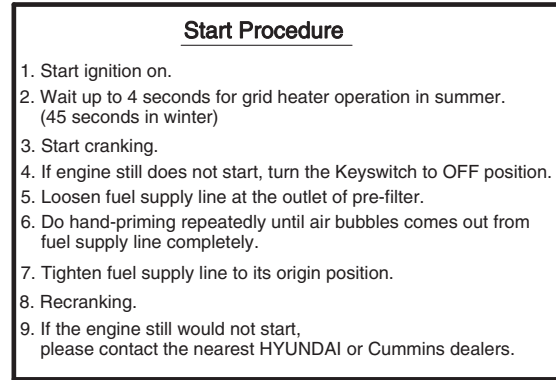

7609A0FW07

24) DIESEL EXHAUST FLUID (item 33)

This warning label is positioned on the right side of the rear frame.

- ※ Fill only the DEF/AdBlue® (Diesel Exhaust Fluid, standardised as ISO 22241).

Aqueous urea solution made with 32.5% high-purity urea and 67.5% deionized water.

- ※ Do not fill the diesel fuel.



760F0FW13

25) ACCUMULATOR (item 39)

This warning label is positioned on the accumulator of the solenoid valve.

- ※ The accumulator is filled with high-pressure nitrogen gas, and it is extremely dangerous if it is handled in the wrong way. Always observe the following precautions.

- ⚠ Never make any hole in the accumulator expose it to flame or fire.
- ⚠ Do not weld anything to the accumulator. When carrying out disassembly or maintenance of the accumulator, or when disposing of the accumulator, it is necessary to release the gas from the accumulator. A special air bleed valve is necessary for this operation, so please contact your Hyundai distributor.



1107A0FW46

26) JOYSTICK STEERING (item 40)

This warning label is positioned on the left side of the cab.

- ※ While traveling on public roads, the steering wheel must be used and joystick steering must be prohibited.
- ※ Please refer to the page 3-51 for details.

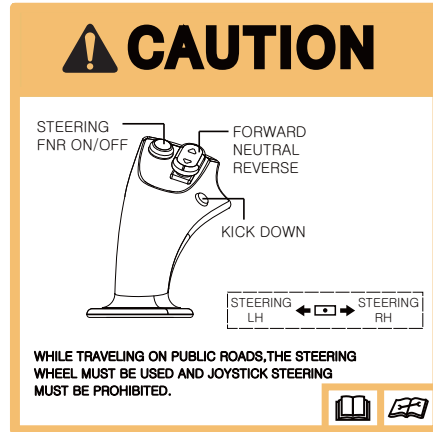

960A0FW05

27) CAUTION (WATER SEPARATOR, TURBOCHARGER) (item 41)

This warning label is positioned on the rear side window of the cab.

- ▲ In order to protect high pressure fuel system, please drain water in water separator before starting the engine.
- ▲ In order to prevent turbocharger failure, please allow more than 5 minutes' cool down period (no load low idle operation) before shutting the engine off.

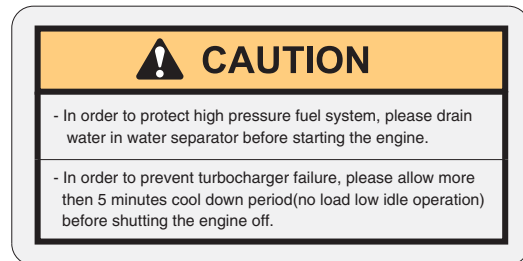

120090SL02

28) TILT HANDLE (item 42)

This warning label is positioned on the right side window of the cab.

- ※ The right side window can be used as an alternate exit.
- ※ Refer to the page 3-60.

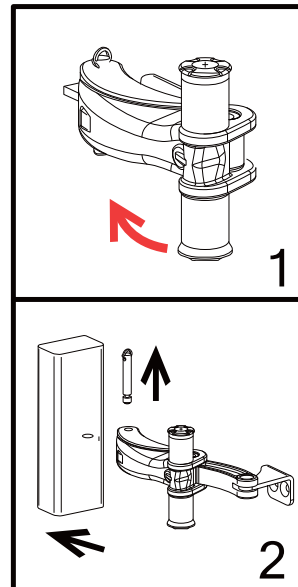

760F0FW14

29) FUEL SHUT OFF (item 43)

This warning label is positioned on the hydraulic tank.

- ※ Fill only the hydraulic oil.
- ※ Do not fill the diesel fuel.
- ⚠ Relieve tank pressure with the engine off by removing the cap slowly to prevent burns from hot oil.

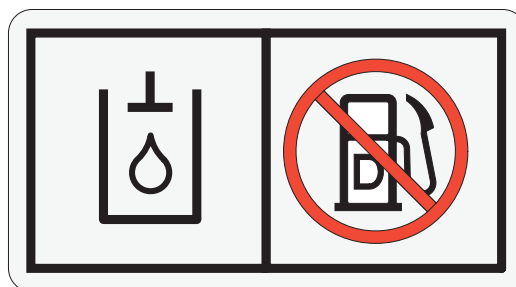

140WH90FW51

30) ULTRA LOW SULFUR DIESEL (item 44)

This warning label is positioned on the left side of fuel filler neck.

- ※ Use ultra low sulfur fuel only.
- ※ Ultra low sulfur fuel sulfur content ≤ 15 ppm
- ※ If ultra low sulfur diesel is not used, the aftertreatment diesel particulate filter can be damaged.

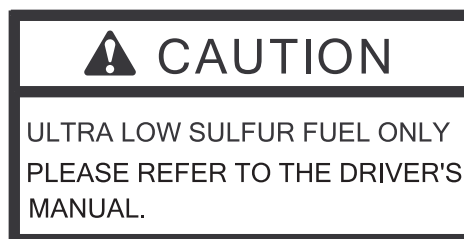

2609A0SL03

31) REFRIGERANT (item 45)

This warning label is positioned on the right side of engine hood.

- ⚠ Inhaling air conditioner refrigerant gas through a lit cigarette or other smoking method or inhaling fumes released from a flame contacting air conditioner refrigerant gas, can cause bodily harm or death.
- ※ Refer to the page 6-50.

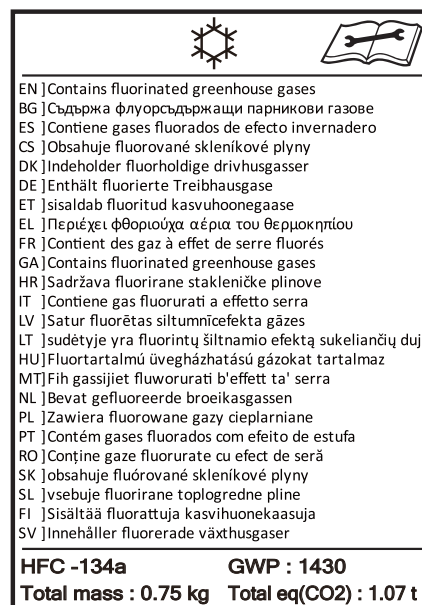

960A0FW30

32) NO STEP (item 47)

This warning label is positioned on the engine hood.

▲ **Don't step on the engine hood.**



9800FW08



955TM0FW20

33) EMERGENCY FIRE HOLE (item 49)

This warning label is positioned on the inside of inlet cover.

※ **Refer to the page 4-29.**

34) QUICK COUPLER (item 48)

This warning label is positioned on the middle of the boom.

※ **Serious injury or death can result from dropping bucket.**

※ **Operating the machine with attachment switch unlocked or without safety pin of moving hook can cause the bucket to drop off.**



757TM9A0FW30

MACHINE DATA PLATE

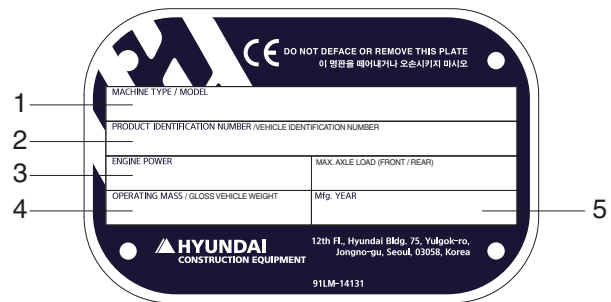
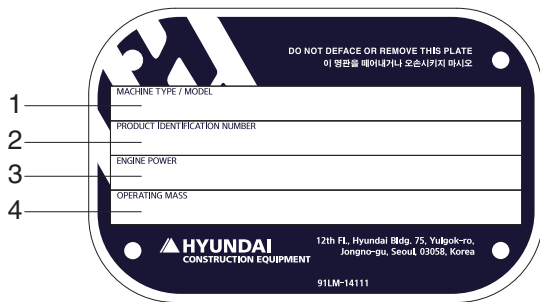

FOR EU ONLY



ROPS

76090FW06A

- | | | | | | |
|---|----------------------|---|-------------------------------|---|--------------------------|
| 1 | Machine type / model | 2 | Product identification number | 3 | Engine power |
| 4 | Operating mass | 5 | Manufacturing year | 6 | Maximum certified weight |

※ The product identification number assigned to this particular machine and should be used when requesting information or ordering service parts for this machine from your authorized HYUNDAI dealer. The product identification number is also stamped on the frame.

GUIDE

1. DIRECTION

The direction of this manual indicate forward, backward, right and left, when machine is on the traveling direction.

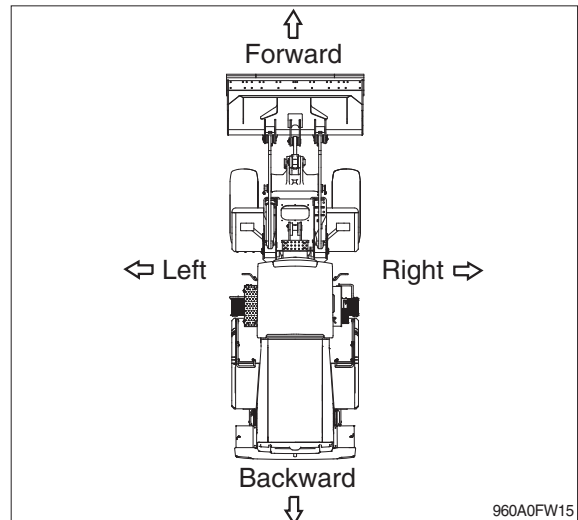

2. SERIAL NUMBER

Inform following when you order parts or the machine is out of order.

1) MACHINE SERIAL NUMBER

The numbers are located on the left side of the rear frame.

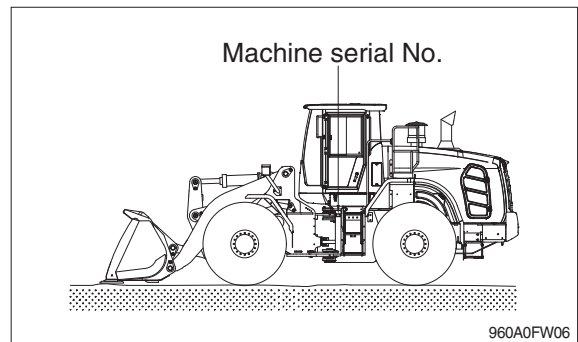

2) ENGINE SERIAL NUMBER

The numbers are located on the engine name plate.

It is also located on the left side frame of the cab inside.

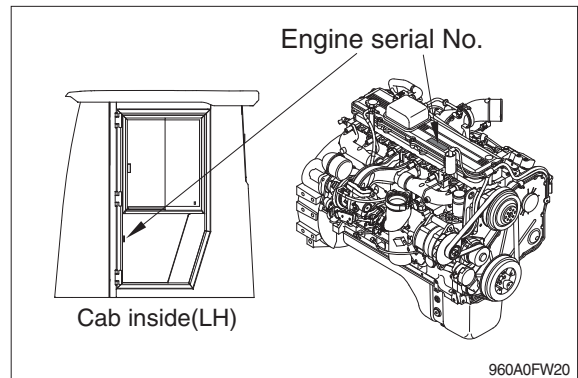

3. INTENDED USE

This machine is designed to be used mainly for the following work.

- Excavating work - Leveling work - Loading work - Transporting work

※ Please refer to the section 4 (efficient working method) further details.

4. SYMBOLS

▲ Important safety hint.

△ It indicates matters which can cause the great loss on the machine or the surroundings.

※ It indicates the useful information for operator.

 **WARNING**

CALIFORNIA PROPOSITION 65

Breathing diesel engine exhaust exposes you to chemicals known to the State of California to cause cancer and birth defects or other reproductive harm.

- Always start and operate the engine in a well-ventilated area.
- If in an enclosed area, vent the exhaust to the outside.
- Do not modify or tamper with the exhaust system.
- Do not idle the engine except as necessary.

For more information go to www.P65warnings.ca.gov/diesel.

2. SAFETY RULES

Safety Message

Intended Use

Machines should be operated in accordance with the procedure described in the Operator manual.

The products described in the Operator manual are designed and manufactured mainly for the following purposes:

- Loading work
- Leveling work

Do not operate the machine for any purpose other than those stated above or in areas where there are potential risks. Make sure that you comply strictly with the safety regulations at all times. Please contact Hyundai Construction Equipment Co., Ltd. or your dealer for more information.

It is strictly prohibited to operate or use the machine in any of the following cases:

- Operation by an unskilled worker
- Lifting a worker up
- Transporting inflammable or dangerous materials
- Driving down or extracting piles with the bucket
- Towing damaged vehicles

Safety guidelines

Most safety accidents related to the operation, maintenance/ inspection, and repair of the machine result from a failure to comply with the safety rules or to take adequate preventive measures. Safety accidents can be prevented in advance by eliminating potentially hazardous situations. In particular, the operator should pay attention to potential risks. In addition, the operator should attend all mandatory training courses on the operation of the machine, and fully understand how to use the tools.

Improper operation, refueling, inspection or repair of this machine may cause serious injury or death.

Do not attempt to operate, refuel, inspect or repair this machine before reading and understanding the product information on such tasks.

This manual describes preventive measures and warnings about the product. Neglecting the warnings about potential risks may result in injury or death of the operator or workers in the vicinity of the machine during its operation.

Risk elements are marked with safety warning labels (**Danger, Warning and Caution**), as described below.



This **Danger** label indicates a high level of risk. Neglecting the warning may result in serious injury or death.



This **Warning** label indicates a medium level of risk. Neglecting the warning may result in serious injury or death.



This **Caution** label indicates a low level of risk. Neglecting the warning may cause moderate or minor injury.

General Safety Information

Unauthorized modification

Any attempt to modify the machine, including the use of unauthorized accessories or spare parts, may have adverse effects on the conditions of the machine and its ability to function as it was designed. Do not attempt to modify the machine in any way without the written consent of the company in advance. The company bears the right to disclaim all quality assurance of a product that is modified without its advance approval.

Never modify the operator's cabin by welding, grinding, drilling holes or adding attachments unless instructed by Hyundai Construction Equipment in writing. Changes to the cabin can cause loss of operator protection from roll-over and falling objects, and result in death or serious injury.

If the user performs unauthorized modification of the product, the user shall fully be responsible for any damages to the machine resulting from the effects of such modification.

1. The attachment, the accessory, or the spare part has been made or distributed by Hyundai Construction Equipment and has been installed according to approved methods described in a publication available from Hyundai Construction Equipment.
2. Any modification should be approved by the company in writing.

ROPS/FOPS

The cabin is designed to guarantee sufficient space to minimize impacts pursuant to ISO 3471 of Rollover Protective Structures (ROPS). If any additional devices are installed that exceed the Max. certified weight indicated on ROPS name plate, the ROPS certification may be nullified. The protective structure of the cabin should be replaced immediately if it is permanently deformed or damaged.

Machines operated in areas where there is a risk of objects falling onto the cabin are fitted with a Falling Object Protective Structure (FOPS) pursuant to ISO 3449.

Fire and Explosion

Prevention of fire

The following actions should be taken to minimize the risk of fire :

- Do the visual inspection before operating the machine to check for any risk of fire.
- Do not operate the machine if there is a risk of fire.
- Be sure to identify the primary exit and alternative exit of the machine, and fully understand how to use the exits in the event of a fire.
- Do not perform any welding or drilling work on the engine cover.

(Keep the engine compartment free from the build-up of inflammable materials such as dead leaves, small branches, paper, and other types of trash.)

- Keep the covers of the major parts of the machine closed. Make sure that the covers operate normally in order to use firefighting equipment in the event of a fire.
- Be careful when handling fuel. Fuel is a highly inflammable material.
- Always stop the engine when refueling the machine.
- Remove any build-up of inflammable materials from the machine.

Do not operate the machine near a naked flame.

- All fuels and most lubricant and coolant mixtures are inflammable materials, so special care should be exercised when handling such materials to prevent fire and explosion.
- Keep all fuels and lubricant in adequate containers.
- Never smoke in the area where refueling is taking place or in the space for handling battery electrolytes and other inflammable materials.
- Oil leaked to a hot surface or electronic component may cause a fire.
- Do not operate the machine if there is an oil leak. Repair the source of the oil leak, and wipe clean any leaked oil before operating the machine.

- Keep the electric connectors clean at all times, and check the connections for signs of loosening at regular intervals.
- Do not weld or take a flame cutting pipe or tube through which gas or any inflammable fluid must flow. Check every pipe or tube for signs of abrasion and deterioration, and replace it if damaged.

- Dust or particles generated when repairing the non-metallic hood or fender are inflammable or explosive. Repair such parts in a ventilated area well away from flames or sparks, and be sure to wear suitable PPE(Personal Protective Equipment).



Prevention of explosion

The following actions should be taken to minimize the risk of explosion:

- Preheating function is provided to certain machines that are used in extremely cold environments.
- Never use starting aid fluid in a low-temperature environment as it can have an adverse effect on the engine performance and may cause an explosion.
- Do not attempt to recharge a frozen battery. Forcibly recharging a frozen battery may result in an explosion.
- Great care should be exercised when handling the batteries. Never let a tool make contact with the positive pole and the frame of the machine simultaneously. Sparks may be generated, resulting in an explosion.
- The voltage of the battery to be recharged should be identical to the voltage of the recharger. Incorrect voltage may cause overheating and explosion.
- Do not use or charge the battery if the level of electrolytes in the battery is lower than the minimum level. Regularly check the electrolyte level, and refill the distilled water to the maximum level.
- Do not try to start the engine using an unsuitable booster cable as it may result in an explosion and serious injury. Only use the booster cable to start the engine in a ventilated open space, as starting the engine with a booster cable may generate inflammable gas.
- When hydraulic equipment and piping are overheated, inflammable gas or airborne particles may explode. Make sure to protect and insulate such parts to prevent overheating.

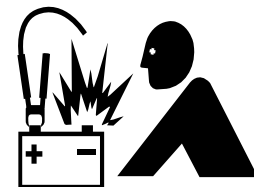
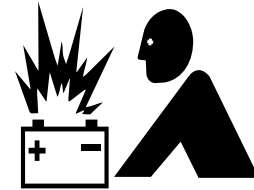

Corrective Actions Before and After a Fire

In the event of a fire in the machine, the top priority should be the safety of the operator and workers in the work area.

In the event of a fire at a level that does not endanger the operator or workers, the following actions should be taken:

- Move the machine well away from any inflammable materials (e.g., fuel, engine oil, clothes, and bits of wood) and adjacent buildings.
- If the engine is running, it may cause a persistent fire. Stop the engine without delay.
- In the event of an electric short, disconnect the batteries to eliminate the main ignition source.

In the event of an electricity leak resulting from damage to the power wiring caused by fire, disconnect the batteries to eliminate the secondary ignition source.

If a fire becomes too large to control, assess the following risks :

- If the machine is mounted with wheels, the tires may be subject to a risk of combustion and explosion, and high-temperature particles may splash into the air.
- The tank, accumulator, hose and fitting may burst into flames, splashing fuel and scattering particles throughout the surrounding area.

If you have to handle a machine that has been damaged by fire or one that is exposed to excessively high heat after extinguishing a fire, take the following precautions:

- Wear thick protective gloves and protective goggles.
- Never touch any materials left after combustion with your bare hands.
- Avoid contact with melted polymer materials (e.g., plastics).

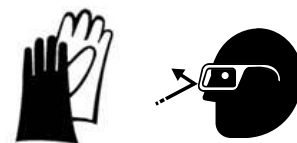
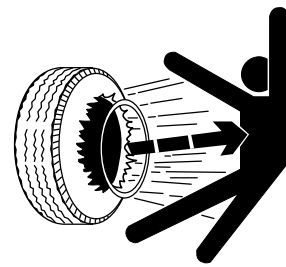

Information on fire extinguisher

Fire extinguishers (if equipped) should be kept in a fully operable condition, and be inspected by a qualified person on a regular basis. Workers should complete a training course on the use of fire extinguishers in advance.

Use fire extinguishers in accordance with the following procedures, if required:

- ① Pull the safety pin of the fire extinguisher first.
- ② Extend the nozzle, and stand toward the fire.
- ③ Aim the nozzle at the flames, and firmly press the top and bottom handles.
- ④ Stand in a downwind position, and evenly spray the foam over the flames.

If the weight of the fire extinguisher exceeds 4.5 kg, mount the extinguisher in a location near the bottom of the cabin. Do not mount the fire extinguisher at a level higher than one third of the height of the cabin.

Do not weld or drill ROPS to mount a fire extinguisher. Contact your dealer or distributor for more information about the correct mounting of fire extinguishers.











Health and Safety

Personal protective equipment

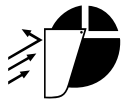
The wearing of personal protective gear is mandatory for protecting the human body from hazardous chemicals and hazardous environments.

The wearing of personal protective gear is a means of preventing disaster, and should not interfere with the performance of jobs. It is designed to sufficiently protect the human body from hazardous environments and materials, and should be kept in a place where it is easily accessible by the operator.

List of personal protection gear

Name	Symbol	Remarks
Safety helmet		Protects the head from falling objects, and reduces risks when falling down.
Dust mask		Air-purifying dust mask should not be worn in workplaces with an oxygen concentration of less than 18%.
Gas mask		Prevents the inhalation of mist, airborne particles, or protects against the spray of hazardous chemicals.
Welding helmet		Blocks airborne dust and slag, and shields the face from bright light during welding.
Protective clothing		Blocks dust, mist and hazardous chemicals, and protects against burns.
Protective gloves		Electric insulation gloves: Should be worn when working in areas with a high risk of electric shock. Chemical protective gloves: Should be worn when working in areas where there is a risk of contact with hazardous chemicals including materials leaked from batteries.
Protective goggles		Protects the eyes from dust, particles and airborne materials in work areas.
Earplugs and earmuffs		Wear earplug and earmuffs separately or in combination depending on the level and duration of noise.
Safety shoes		Protects the feet from falling objects, impacts, and sharp objects.

Health and safety instructions in hazardous environments

Comply with the following instructions during operation and maintenance of the machine.

When handling oil

Failure to wear personal protection may result in burns caused by contact with a high-temperature liquid. Make sure you wear protective goggles, protective gloves and protective clothing when handling oils such as hydraulic oil and engine oil.

If the eyes come into contact with oil, wash them with a sufficient quantity of water for 15 minutes or longer. If the skin comes into contact with oil, take off contaminated clothes and shoes, and wash the skin with soap and water for 15 minutes or longer.



When handling the battery

If battery electrolyte leaks while handling the battery, the sulfuric acid contained in the electrolyte may cause burns. The lead components in battery electrolyte are toxic, so be sure to wear protective gloves and protective clothing. Do not forget to wash your hands after handling the battery.

If a part of your body not protected by personal protective equipment comes into direct contact with battery electrolyte, immediately wash the affected part with flowing water for 20 minutes or more, and then see a doctor without delay.

If you accidentally swallow battery electrolyte, drink lots of water and do not forcibly induce vomiting, and then see a doctor without delay.

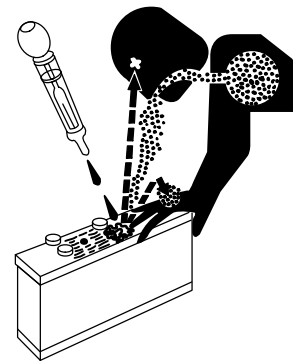

When handling refrigerant

Make sure you wear protective goggles, protective gloves and other personal protective equipment when handling refrigerant to prevent direct contact of the skin with the refrigerant. Wear protective gloves made of materials that are resistant to chemicals (such as neoprene and butyl rubber).

Never smoke when handling refrigerant.

If refrigerant comes into direct contact with the skin, wash the skin with warm water immediately.



When handling coolants

After operation of the machine the coolant is of high temperature and high pressure, and is retained inside the engine radiator and the heater line. Direct contact of the skin with the coolant may result in serious burns. Open the cap of the radiator only after the engine has sufficiently cooled and the pressure has dropped to a safe level.



Coolant contains toxic and combustible ethylene glycol, and should be handled in a cool, well-ventilated place only when wearing protective goggles, protective gloves, protective clothing, and a gas mask.

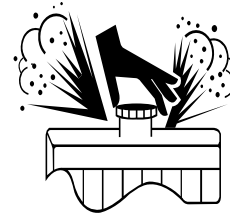

Avoid inhaling airborne particles or spray from coolant. If the substances make contact with skin or eyes that are not protected by personal protection gear, immediately wash the skin and eye with flowing water for 20 minutes or longer.

When working in a place subject to airborne particles and falling objects,

Make sure you wear a safety helmet, protective goggles and safety shoes to prevent injury from such particles and objects. Earplugs or earmuffs may be necessary when working in a noisy place.









When working in places with a high level of noise

When the operator is exposed to the noise exceeding 90 dB (A) for 8 hours or longer, wear earplugs or earmuffs.

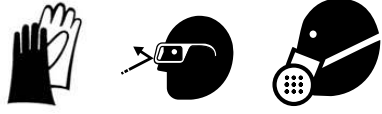

Personal protection gear for various situations

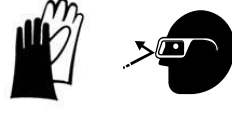
Situation	Symbol
Oil handling	
Battery handling	
Refrigerant handling	
Coolant handling	
Repair by welding	
Working in areas subject to airborne particles and falling objects	
Working in places with a high level of noise	
Handling machines damaged by fire or exposed to excessively high temperature	

Noise and Vibration

Information on vibration

This part describes the vibration data of the machine, and methods of calculating the vibration level.

The vibration level of the machine varies according to any of the following conditions:

- Driving habits of the operator (i.e. aggressive/mild temperament when driving)
- Quality of seat and suspension
- Type of machine, attachments, and conditions of machine
- Conditions of work site, working environment, ground surface conditions, and weather

Vibration also varies according to the duration of operation. Accordingly, it is not possible to precisely calculate the vibration level of the machine; however, it is possible to predict the level.

Physical Agents Directive 2002/44/EC defines the exposure action value as 0.5 m/s^2 , and the exposure limit value as 1.15 m/s^2 . If the predicted value is near the exposure action value or exposure limit value, the predicted value should be assumed to exceed the two latter values, and necessary action should be taken.

As regards the actions to take according to vibrations, refer to the following table :

Daily vibration exposure (A(8))	Vibration exposure range	Actions to be taken
$A(8) \leq 0.5 \text{ m/s}^2$	Exposure action value or lower	When approaching the exposure activity value, reasonable measures should be taken to minimize exposure to vibration. The relevant information and opportunities for training on vibration reduction should be provided to the operator.
$0.5 \text{ m/s}^2 < A(8) \leq 1.15 \text{ m/s}^2$	Exceeding the exposure action value, but not exceeding the exposure limit value	It is required to execute certain measures for reducing exposure to and risks of vibration to the minimum. The health of an operator who has been exposed to excessive vibration should be examined.
$1.15 \text{ m/s}^2 < A(8)$	Exceeding the exposure limit value:	Immediate action is required to reduce the vibration exposure level to below the exposure limit value.

The vibration level can be predicted based on the information in the following table which is used to calculate the daily level of vibration exposure.

Predict the vibration level in the three vibration directions of axes X, Y, and Z. The mean vibration level should be used under normal operation conditions. Scenario factors from mean vibration level based on operation by skilled operator and on smooth terrain are excluded. Scenario factors are included to obtain the mean vibration level based on aggressive operation and severe terrain to assess the expected vibration level.

※ **All vibration values are indicated in m/s^2 .**

Instructions on mitigating vibration

Machines should be correctly adjusted and maintained to ensure smooth operation. The terrain conditions should be observed. The following instructions will help reduce the whole body vibration level:

- ① Use machines and attachments of the correct types and sizes.
- ② Maintain the machines pursuant to the manufacturer's recommendations.
 - Brake and steering systems
 - Controls, hydraulic system and linkage
 - Tire pressure
- ③ Maintain and provide good terrain conditions.
 - Remove any large rocks or obstacles.
 - Fill gutters or holes.
 - Keep the vibration level minimal by adjusting the speed and driving path
- ④ Use a driver's seat that satisfies ISO 7096.
 - Adjust the driver's seat and suspension for the weight and the size of the operator.
 - Inspect the suspension and adjusting devices of the driver's seat.
- ⑤ Perform the following maneuvers without using excessive force :
 - Steering
 - Braking
 - Accelerating
 - Gear shifting
- ⑥ Move the attachments smoothly.
- ⑦ Adjust the speed and path of machine to keep the vibration level minimal.
 - Operate the machine so as to avoid obstacles and rough terrain.
 - Decelerate the machine when driving on rough terrain.
- ⑧ Keep the level of vibration minimal when working for a long time or driving for a long distance.
 - Use a machine mounted with suspension system.
 - Use the machine's drive control system (optional).
 - If the machine is not fitted with a drive control system, reduce the speed.
 - Transport the machine when moving between worksites; do not drive the machine to get to another worksite.

⑨ The operator's convenience may be reduced by various risk factors. Comply with the following conditions to effectively ensure the operator's comfort and convenience.

- Adjust the driver's seat adjustment device to allow a convenient posture.
Adjust the angles of the mirrors to minimize awkward, compromised posture
- Avoid working for an excessively long time, and take regular breaks.
- Do not jump on or from the cabin.
- Minimize repeated handling of loads and lifting of loads.
- The vibration information and calculation procedures are based on <ISO/TR 25398>, which has been defined according to the emission of vibrations measured under the actual working conditions of the machines.

Information on noise

Noise level (EN 474-1:2018 and 2000/14/EC) are as follows :

- Sound pressure level (LpA) : See pages 0-3.
- Sound power level (LwA) : See pages 0-3.

Emergency situations

In the event of an emergency situation, use the emergency hammer installed inside the cabin to break the windshield of the cabin, and carefully escape from the cabin. The emergency hammer should always be kept inside the cabin for emergencies, and should not be removed or used for other purposes. If the emergency hammer is lost, replace it immediately.

Keep a first-aid kit inside the cabin or in another place at the worksite for safety accidents.

Keep contact information (e.g., phone number) to request help with an emergency situation or injury.

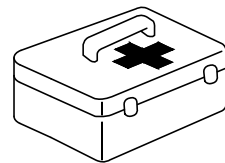
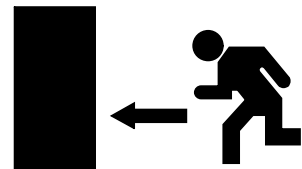

Safety Information on the Machines and Operation

Before Operating the Machine

Checking the worksite

Carefully examine the following conditions and take the necessary actions, if required, to prevent risk factors before operating the machine:

- Check the weather condition at the worksite (e.g., fog, rain, etc.). Fog or heavy rain may narrow the operator's field of vision, or render the machine inoperable. In particular, the operator should bring the bucket down to the ground in the event of thunder and lightning, and evacuate to a safe place.
- Check the worksite for obstacles, and avoid collisions with such obstacles during operation. Check the surroundings of the machine for any obstacles that may hinder operation.
- Check the worksite for buried waterlines, telecommunication cables, power cables and oil pipelines in advance, and avoid damaging them.
- If the terrain of the worksite is too rough for normal operation of the machines, flatten the terrain before operating the machines. Make sure that the ground of the worksite is not soft as it may cause hazards during operation.
- If the worksite is a marshy place (e.g., shallow river, large or small lake, swamp, etc), check the conditions and the depth of marshy areas, and the flow rate before driving or operating the machines.
Do not operate the machines underwater.
- Do not operate the machines on cliffs or at the end of a road on soft ground as the machine may overturn.
- When operating the machine in areas with pedestrian or vehicle traffic, or in a zone in the vicinity of such an area, appoint workers exclusively responsible for controlling the traffic, or install fences or blocking wall to separate the worksite from the traffic area. Prevent unauthorized workers or machines from accessing the worksite.

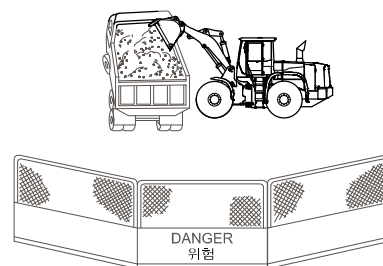

Operator conditions to be checked before operating the machine

- The machine shall be operated by authorized and skilled operators only.
- The operator should wear clothes and personal protection gear that are appropriate for the work environment.
- The operator should only be permitted to operate the machine under normal conditions after checking the state of the operator. Operator under the influence of alcohol or drugs, or an extremely exhausted operator should not operate the machine.
- The operator should read and fully understand the operator's manual before operating the machine.
- The operator should fully understand the details and procedures of the work to be performed.
- If a risk of a safety accident is suspected, consult sufficiently with the responsible worker, and only perform the work after taking the necessary preventive measures.

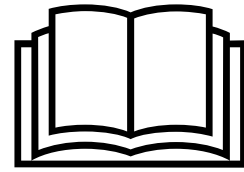

Machine conditions to be checked before operating the machine

- Check the machine for abnormal noise, vibration or heat, and for the leakage of engine oil, hydraulic oil, fuel or refrigerant.
- Remove any substances (e.g., inflammable materials such as wooden chips, dead leaves and pieces of paper) from the engine and the battery. The buildup of such substances may cause a fire.
- Do not operate a machine that needs repairing without taking actions for repair.
- Operate the machine only after making sure that the regular inspection and service recommended in the operator's manual have been executed.

- Adjust the operator's seat to suit the physical condition of the operator. Check the seatbelt for damage, and replace it if damaged. Do not store unnecessary objects or tools in the cabin.
- Keep clean all parts related to the visibility, such as the windshield and rearview mirror. In particular, adjust the rearview mirror to ensure that the operator's field of vision is clear.
- Check the acoustic alarms (e.g., the horn and warning signal when driving backward or moving) for normal operation.



During Operation of the Machine

Getting on and off

- Do not jump on or off the machine.
Do not try to get on or off the machine while it is moving.
 - Get on or off the machine using the handrail and step (or stepladder, if any). Always keep the handrail and step clean and free from mud or oil.
 - Wear anti-slip shoes.
 - Comply with the principle of three-point contact* by contacting the machine with either both hands and one foot or vice versa when getting on or off the machine.
 - Do not sit on a seat not suited or intended for sitting.
- ※ **Three-point contact means making contact with the machine with both hands and one foot, or with one hand and both feet.**

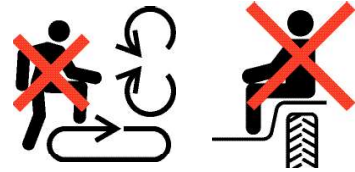

During operation

- The operator should start the engine only after sitting on the operator's seat. Make sure that all levers are shifted to the neutral position before starting the engine.
- If there are any obstacles at the worksite, pay attention to prevent collision of the machine with such obstacles, particularly when turning and moving backward. Make sure that there are no obstacles when turning and moving backward.
- When lifting a load, the capacity of the machine and the size and weight of the object to be lifted must be considered. Do not lift a heavy object with slings by suspending the slings on the tooth of the bucket.
- Do not allow any worker to stand under the bucket.

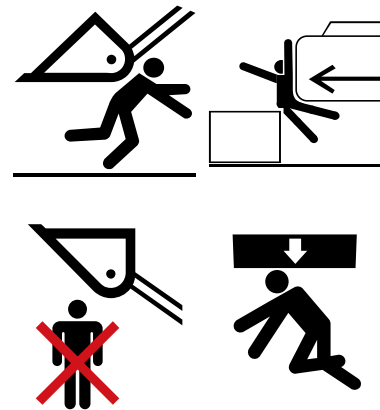

Operation on a slope

Comply with the following conditions when operating the machine on a slope:

- Do not work on slopes of 10° or more.
- The maximum climbing angle of the machine on a slope is 30°. Do not operate the machine at an angle exceeding this value.
- If operation of the machine on a slope is unavoidable, perform the work after flattening the ground.

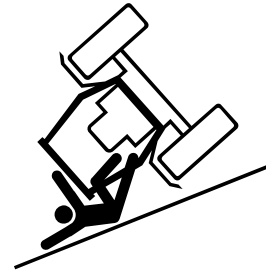

- When operating the machine laterally on a slope, there is a high risk of machine overturning or slipping. Do not operate the machine in such conditions.

- Do not operate the machine on a slope covered with wet grass or a thick layer of dead leaves, as the machine may slip.

- Do not park or stop the machine on a slope.

If parking or stopping the machine on a slope is unavoidable, bring the bucket down to the ground, and support the wheels with wheel chocks.

- When traveling up a slope, operate the machine at a slow speed with the attachment extended forward to keep the machine balanced, and with the bucket raised at least 20 ~30 cm from the ground.

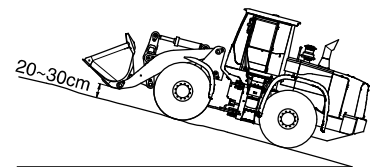

- Never travel down a slope in neutral. Keep the bucket 20~30 cm above the ground, and use the bucket as a brake in an emergency situation.

- If the engine suddenly stalls, immediately bring the bucket to the ground.

- If the fuel gauge reaches the red zone while operating the machine, immediately refill with fuel. (If the machine operates on a slope under these conditions, air may be introduced into the engine, causing it to stall suddenly.)

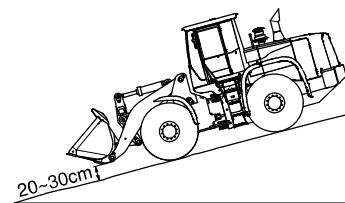

Cautions to Be Taken When Driving the Machine

- If you operate the machine with the parking brake on, it may cause serious damage to the parking brake disk.
- Select the appropriate gear for the driving speed.
- Do not change direction when driving the machine at max. speed as this may cause serious damage to the transmission.

- Only drive the machine for short distances on the road.
- Make sure you fully comply with the local road traffic regulations and legislation of your country when driving on the road.
- Please note that the machine is wider and travels at a lower driving speed than other vehicles on the roads.
- Pay attention to any vehicles behind your vehicle, and allow them to overtake your vehicle safely.

- Check the following conditions before driving the machine on the public road :
 - Remove any dirt and sand from the machine.
 - Empty the bucket and move it to the driving position (40~50 cm above the ground) and fix it.
 - Close the windshield. Turn the working light off.
 - Wear the seat belt.
 - Use the lighting devices, such as the headlights, emergency warning light and rotating beacon, pursuant to the local road traffic legislation.
 - Pay attention to people in the vicinity of the machine.
 - Do not operate the machine on roads or bridges where the machine exceeds the weight limit.
 - Familiarize yourself fully with the width, length and height of the machine.
 - Check the tire pressure.
 - When traveling for a long distance, stop the machine after every 40 km or on an hourly basis, and take a break.
 - Check the level of fuel and coolant.
 - Never shift the gear to the neutral position when driving down a slope.
 - Changing direction when operating the machine on a slope is dangerous.
 - Do not drive on a slope of 30° or more.
 - Drive slowly when traveling the machine on rough terrain or moving over obstacles.
 - Install chains on the tires when operating the machine on slippery roads covered with snow or rainwater, and do not attempt to start, stop or turn the machine suddenly.
 - Be sure to avoid any obstacles when traveling the machine on paths.

Driving position

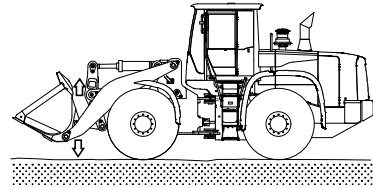

Operations to be avoided or prohibited

- Pay attention when operating the machine in an enclosed space as this may result in the risk of a buildup of hazardous gases.



- If the machine is operated in the vicinity of a high-voltage line, there is a risk of death or serious injury.
- Make sure you are fully aware of the height and working radius of the machine, and maintain the minimum safety distance.

Voltage	Minimum safety distance
6.6 kV	3 m (10 ft)
33.0 kV	4 m (13 ft)
66.0 kV	5 m (16 ft)
154.0 kV	8 m (26 ft)
275.0 kV	10 m (33 ft)

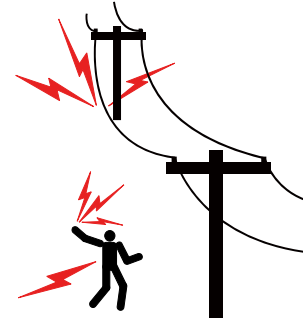

- In the event of contact with a high-voltage line, keep sitting on the operator's seat until the electric current has been shut down.
- Warn any workers on the ground in the vicinity of the machine not to make contact with the machine.
- If leaving the machine is unavoidable, jump down to a place free from any contact with the machine.
- Avoid operating the machine on soft ground, a slope or cliff as there is a risk that it may overturn. Pay special attention when it is raining as the rainfall may soften the ground.
- When operating or driving the machine underwater, check the floor conditions, depth of water and flow rate, and make sure that the top roller and axle housing are not immersed in water.
- Do not operate the machine under adverse weather conditions caused by overcast skies, snow and rainfall.
- Do not turn or travel the machine when the bucket is stuck in the ground.

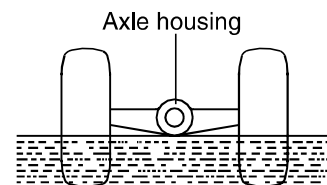
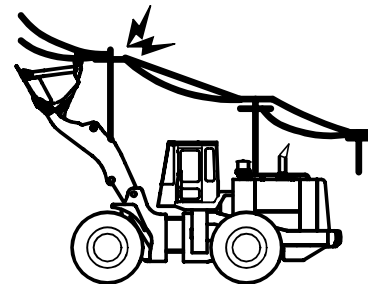

Cautions when operating in specific areas

Operating in extremely cold environments

- Do not attempt to start, stop or turn the machine suddenly as this may cause it to slip. There is potential for the machine to slip.
- Snow-covered or frozen ground may be slippery and dangerous.
- Idle operation of the machine may be required to elevate the engine temperature during startup.
- An impact resulting from a sudden movement of the boom or the attachments at an extremely low temperature may cause serious damage to the machine.
- The working cycle or loading weight might be reduced to lower than those under normal conditions.
- Check the following conditions before operating the machine :
 - Warm up the engine for 3~4 seconds when starting up the engine.
 - Always fully charge the battery. A discharged battery will freeze earlier than a fully charged battery.
 - Use engine oil and fuel that are appropriate for the temperature.
 - Keep the fuel tank full.
 - Remove any moisture from the fuel tank, and change the fuel filter regularly.
 - If the fuel filter is frozen, the flow of fuel may be blocked.
 - Pour the proper volume of antifreeze into the coolant.
 - Wait until the various parts of the machine reach the operating temperature after starting the engine.
 - Make sure that every controller and function of the machine operates normally.
 - Remove any dirt, snow and ice from the machine after completing the operation, and park the machine on a wooden pallet.

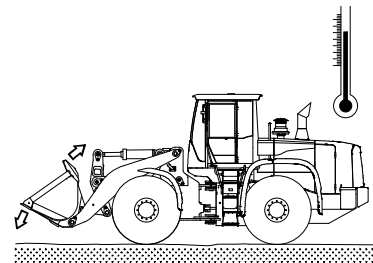

Operating in extremely hot environments

- Continuous operation of the machine for a long period of time may cause the machine to overheat. Pay special attention to prevent the overheating of respective parts such as the engine and the hydraulic system, and stop the machine and take a break if necessary.
Check the following conditions frequently :
 - Check the level of the coolant in the radiator.
 - Check the radiator grill for clogging by foreign pollutant, and remove them, if any.
 - Check the level of the battery electrolyte.
 - If the battery will not be used for a long period of time, store it in a cool place.
 - Check the hydraulic system for oil leakage.
 - Check the lubrication oil on the respective parts, and top up the oil if necessary.
 - If the paint coating of any parts has been effaced or damaged, coat the parts with paints or treat them with an anti-rust additive.
 - Do not park the machine under direct light for a long period of time.
 - When parking or storing the machine outdoors, use the proper cover to protect the machine from sunlight and dust.

Operating in dusty or sandy environments

- Check the radiator grill for clogging by pollutant, and remove them, if any.
- Check the fuel system, and protect it from dust or sand when refueling.
- Inspect the air cleaner regularly, and replace it if necessary.
- If the gauge lamp on the dashboard lights up and the buzzer sounds at the same time, clean or replace the air cleaner independently of the usual inspection cycle.
- Frequently check consumables such as hydraulic oil and lubrication oil, and change them if necessary. Pay attention care to prevent the introduction of dust or sand when changing the consumables.
- Check the air-conditioner and the heater filters regularly, and clean or replace them if necessary.
- When parking or storing the machine outdoors, use the proper cover to protect the machine from dust and sand.

Operating in rainy or humid environments

- Do not operate the machine in areas where there is heavy rainfall or thick fog.
- If operating the machine in such areas is unavoidable, perform operation after ensuring sufficient field of vision.
 - Use lighting devices such as the head lamp and working light.
 - Warn any workers within the radius of operation of the machine.
- Pay attention when operating the machine on smooth ground as there is a risk of it overturning.
- If the paint coating on any parts has been effaced or damaged, coat the parts with paints or treat them with an anti-rust additive.

Operating the machine in coastal areas

- Special care should be taken when operating the machine in coastal areas as exposed parts may be corroded easily.
- If the paint coating on any parts has been effaced or damaged, coat the parts with paints or treat them with an anti-rust additive.
- Perform inspection and maintenance of the parts promptly.

Cautions during maintenance

Tools

- Use the correct tools for each type of work.
- Using improper tools may damage the machine and its parts.
- Using deteriorated or damaged tools may result in bodily injury.

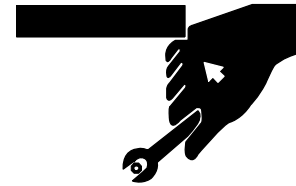

Inspection and servicing

- Prevent access to the machine by all unauthorized workers (other than those authorized during operation of the machine).
- In the event of an inspection park the machine in a flat area and attach it with an 'Under Inspection' sign.
- Clean the machine before inspection or maintenance.
 - When performing inspection or maintenance on a dirty machine, it may be difficult to diagnosis or detect the cause of a problem with the machine, if any.
 - Dust or dirt accumulated on the machine may cause a worker to slip or fall.
 - Wear protective goggles and protective clothes when cleaning the machine using a compressed water jet.
 - Do not spray water or steam directly onto the electronic components.
- Use proper lighting devices when operating the machine in a dark area.
- Use lighting devices that satisfy the explosion-proof requirements when handling inflammable materials such as fuel and hydraulic oil.
- Never attempt to use a direct flame such as a cigarette lighter in lieu of the lighting device.

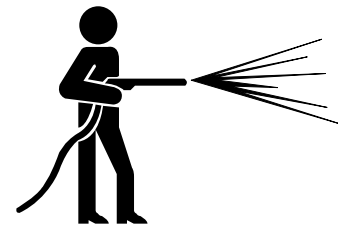

- Check the level of the cooling water after stopping and sufficiently cooling down the engine.
- Sufficiently relieve the inside pressure before opening the cooling water cap.
- The cooling system contains basic components. Pay attention to prevent the skin or eyes coming into contact with the basic components.
- Pay attention to protect the body from contact with hot fluid or parts.
- Replace the filters only after stopping off and sufficiently cooling down the engine.
- Slowly remove the hydraulic oil filter plug to relieve the inside pressure.
- Relieve the pressure from the hydraulic system before disconnecting the lines and fittings.



Collision or cutting

- Never open or remove the engine hood while the machine is in operation.
- Two workers should perform the job while the engine is running:
- One worker should be ready to operate the machine or to turn the engine off from the cabin.
- Keep areas in the vicinity of rotating or moving parts clean.
- Keep articles in the vicinity of the fan clean.
 - Wear safety gloves when handling the wire cables.
 - Wear protective goggles and protective clothes, if required.

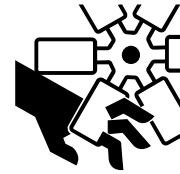
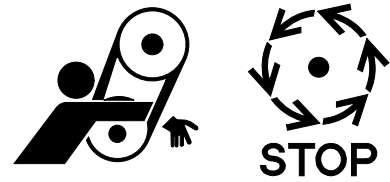

Preventing fire and explosion

- All fuels and most lubrication oils and coolant mixtures are inflammable materials, so special care should be exercised when handling such materials to prevent fire and explosion.
- Oil that leaks on to a hot surface or electronic components may cause a fire.
- Keep all fuels and lubrication oils in adequate containers.
- Do not smoke while refueling fuels, or at the refueling point.
- Do not smoke in a space where battery electrolyte and other inflammable materials are handled.
- Keep the electric connectors clean, and check the connections for signs of loosening at regular intervals.
- Do not weld or cut pipes or tubes through which inflammable fluid flows.

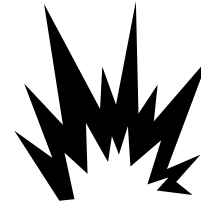

Cautions on decoupling the attachments

- Do not allow unauthorized workers to access the machine.
- Place the operating machine in a safe position.
- Install safety fences around the operating machine.

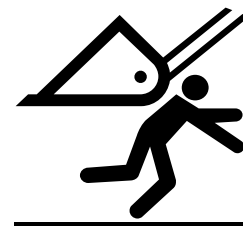

Repair by welding

- Perform repairs by welding in an area where adequate facilities for welding are available.
- Welding work may be subject to risks of gas leak, flame and electric shock.

Welding should be performed only by a qualified welder.

- Take the following precautions when welding:
 - Separate and remove the battery to prevent battery explosion.
 - Perform direct heating in a place free from the risk of explosion.
 - Cover parts such as rubber hoses subject to damage by welding with flame-resistant materials.
 - Wear a welding helmet, protective clothes, protective gloves, and safety shoes.
 - Perform welding work in a well-ventilated place.
 - Remove all inflammable materials from areas in the vicinity of welding work.
 - Provide fire extinguishers.



Precautions to take when working on the machine

- There is a risk of falling when working on the machine.
- Keep the area around the workers' feet clean and tidy.
- Do not spill oil or grease.
- Do not leave tools lying on the floor.
- Be careful on the floor when moving.
- Never jump from the machine.
- When getting off the machine, use the step or handrail and get off the machine while keeping to the principle of three-point contact.
- Wear protective clothes if necessary.
- Do not perform maintenance work in an area where no anti-slipping pads have been installed.
- Replace anti-slipping pads and step treads with new ones if they have deteriorated or no longer function.

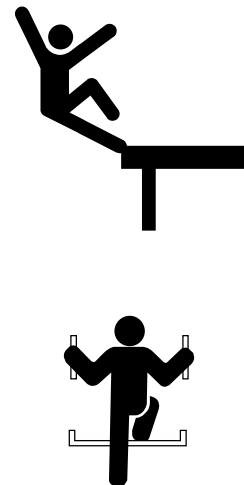

Cautions when working with the high-pressure line or hose

- Make sure that the internal pressure is released before replacing or checking the high-pressure line or hose.
- If the internal pressure is not released, serious injury may result.
- Be careful in the following conditions:
 - Provide fire extinguishers.
 - Leaked oil may penetrate the skin or cause serious injury.
 - Never check for oil leaks with your bare hands.
 - Check an oil leak using a wooden plate or cardboard.
 - Never bend or hit the high-pressure line hard.
 - Do not install a bent or damaged line or hose.
 - Make sure that all of the clamps and protective devices are properly installed.
- Check the pipes and hoses regularly and replace any damaged parts if necessary.

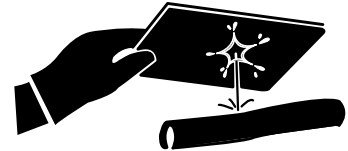

Cautions on inspecting the tire

- Always keep the tires inflated to the proper pressure.
- Overheating or rupture of the tires may result in serious injury.
- Repairing or changing the tires requires exclusive facilities and expertise. Please contact a professional tire repair shop if repairs are necessary.

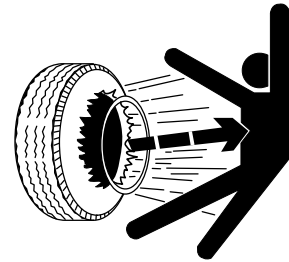

Cautions on inspecting the counterweight

- Never stand beneath the counterweight when installing or removing it.
- Make sure that the status and conditions of the lifting device are normal.



Battery

- The battery contains inflammable materials.
- Never smoke in the vicinity of the battery.
- The battery electrolyte is strong acid. Pay attention to prevent the skin and eyes from coming into contact with the electrolyte.
- If the battery electrolyte accidentally comes into contact the body or clothes, immediately wash off the electrolyte with water.
- If the battery electrolyte is frozen, do not use other devices to start the engine up.
- Always wear protective goggles and protective gloves when working on the battery.
- Always keep the switch in the 'OFF' position when working on the battery.
- Securely fasten the battery cap.
- Always disconnect the battery from the machine before charging the battery.
- Disconnect the cathode (-) first when removing the battery.
- Connect the anode (+) first when connecting the battery.
- Follow the safety procedures when jump starting or charging the battery. Improper connection of the cable may result in an explosion and serious injury.
- Use a voltmeter when inspecting the battery charging.
- Regularly inspect the battery cable, and replace it if damaged.
- A battery cable with exposed wires may cause a short if it comes into contact with the grounding surface.
- A short circuit of the battery cable may cause heat from the battery current and result in a fire.
- If the wires of the ground cable are exposed between the battery and the master switch, the exposed wires make contact with the grounding surface, and the current may bypass to the master switch, which may in turn destabilize the machine operation. Repair or replace the part before operating the machine.

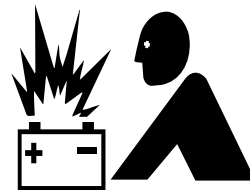
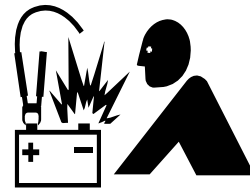

Parking and Storage

Cautions on parking

- Park the machine on the flat ground as possible.
- If parking the machine on a slope is unavoidable, use wheel chocks to prevent the machine from moving.
- Bring the bucket right down to the ground.
- Make sure that all of the switches are turned to the 'OFF' position.
- Make sure that all of the controllers are turned to the neutral position.
- Activate the parking brake.
- Stop the engine, and withdraw the ignition key.
- Close and lock the windshield, door and cover completely.
- Install fences around the machine when parking it on a public road, and put up a warning sign.

Cautions on storage for a long period of time

- Park the machine in accordance with the cautions for parking.
- When storing the machine for a month or longer, pay attention the following conditions to prevent deterioration of the machine performance :
 - Thoroughly clean the machine before storing.
 - Inject sufficient lubrication oil and grease into the injection ports.
 - If the lubrication oil is deficient, top it up. If the oil is contaminated, change it.
 - The lubrication oil may deteriorate during storage. Pay special attention to reusing the oil.
 - The density of the oil may drop during storage.
 - Apply an anti-rust additive to the exposed area of the piston rod of the cylinder in areas where it is likely to rust quickly.
 - Keep the master switch mounted in the power box (or the toolbox on the left of the rear frame of the machine) turned 'OFF'.
 - Top up the antifreeze in the radiator.
 - Keep the machine in a dry indoor environment.
If storing the machine outdoors is unavoidable, store it on a wooden pallet.
 - Keep the exposed area of the piston load of the cylinder covered.
 - Bring the attachments right down to the ground, and keep the wheels and the track immobile by placing wheel chocks.

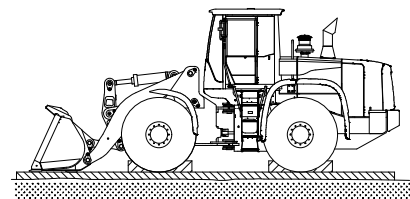

Regular lubrication (during storage)

- Breaking the lubrication film on parts may cause abnormal abrasion during the next operation.
- Start up the engine once a month, perform all of the functions, and apply lubrication oil to every part.
- Check the level of the engine oil and coolant when starting the engine up, and top them up if necessary.
- Thoroughly wipe off any rust-proofing oil from the cylinder and piston rod.
- Sufficiently warm up the engine after starting the engine, and repeat operation of the attachments several times to wear in the parts sufficiently.
- Fully charge and store the battery.
- Store the battery separately for a long period of time under extremely cold weather conditions.
- Check the tire pressure.

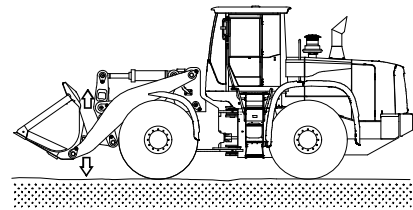

Visibility

Before you start the machine, perform a walk-around inspection in order to ensure that there are no hazards around the machine.

While the machine is in operation, constantly survey the area around the machine in order to identify potential hazards as hazards become visible around the machine.

Your machine may be equipped with visual aids. Some examples of visual aids are Closed Circuit Television(CCTV), AAVM(Advanced Around View Monitoring) and mirrors. Before operating the machine, ensure that the visual aids are in proper working condition and that the visual aids are clean.

If may not be possible to provide direct visibility on large machines to all areas around the machine, appropriate job site organization is required in order to minimize hazards that are caused by restricted visibility. Job site organization is a collection of rules and procedures that coordinates machines and people that work together in the same area.

Examples of job site organization include the following:

- Safety instructions
- Controlled patterns of machine movement and vehicle movement
- Workers that direct traffic to move when it is safe
- Restricted areas
- Operator training
- Warning symbols or warning signs on machines or on vehicles
- A system of communication
- Communication between workers and operators prior to approaching the machine

Modifications of the machine configuration by the user could result in a restriction of the machine visibility. In this case, a new risk assessment shall be performed according to ISO 5006:2017.

Restricted Visibility

The size and the configuration of this machine may result in areas that can not be seen when the operator is seated. The following illustration of visual map provides an approximate visual indication of areas of significant restricted visibility. This illustration indicates restricted visibility areas at ground level inside a radius of 12.00m (40 ft) from the operator on a machine only with the use of right side mirror and left side mirror installed. (without the use of optional visual aids.) This illustration provide areas of restricted visibility for distances outside a radius of 12.00m (40 ft).

This machine may be equipped with optional visual aids (CCTV or AAVM) that may provide visibility to some of the restricted visibility areas. For areas that are not covered by the optional visual aids, the job site organization must be utilized to minimize hazards of this restricted visibility.

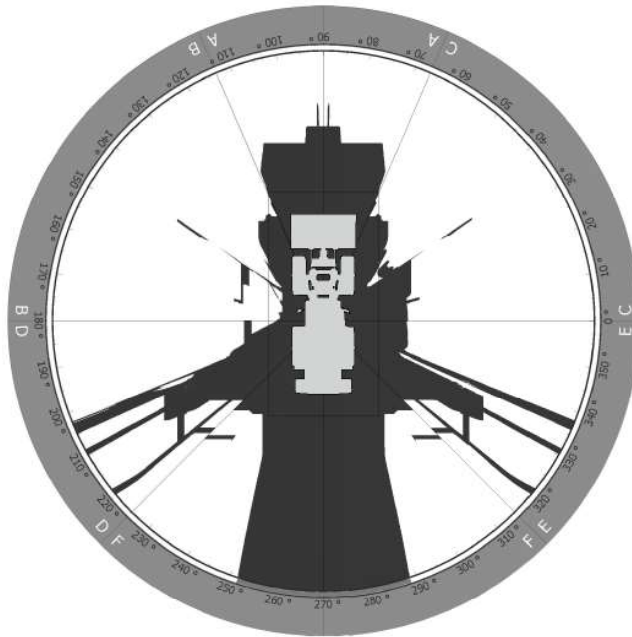

< Top view of the machine at ground level visibility without use of optional visual aids >

※ The shaded areas indicate the approximate location of areas with significant restricted visibility.
(Radius = 12 m / 34 ft)

There is restricted visibility to the area directly behind the machine with no optional visual aids. Failure to make sure the area is clear could result in serious injury or death. Make sure that the area is clear with the other person on the ground before you start the reverse movement.

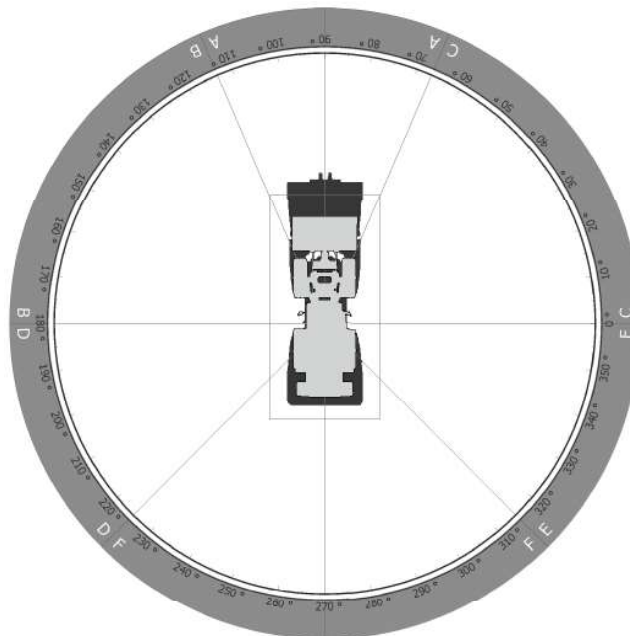

< Top view of the machine at ground level visibility with use of optional visual aids >

※ The shaded areas indicate the approximate location of areas with significant restricted visibility.
(Radius = 12 m / 34 ft)

HL960A XT

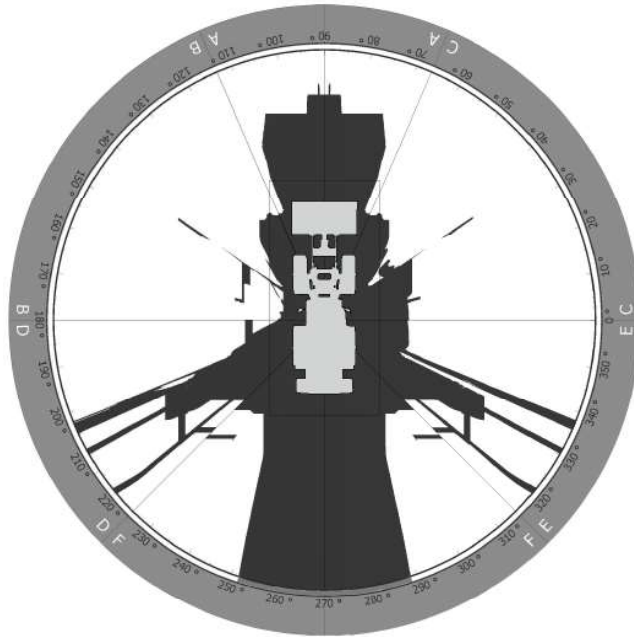

< Top view of the machine at ground level visibility without use of optional visual aids >

- ※ The shaded areas indicate the approximate location of areas with significant restricted visibility. (Radius = 12 m / 34 ft)

There is restricted visibility to the area directly behind the machine with no optional visual aids. Failure to make sure the area is clear could result in serious injury or death. Make sure that the area is clear with the other person on the ground before you start the reverse movement.

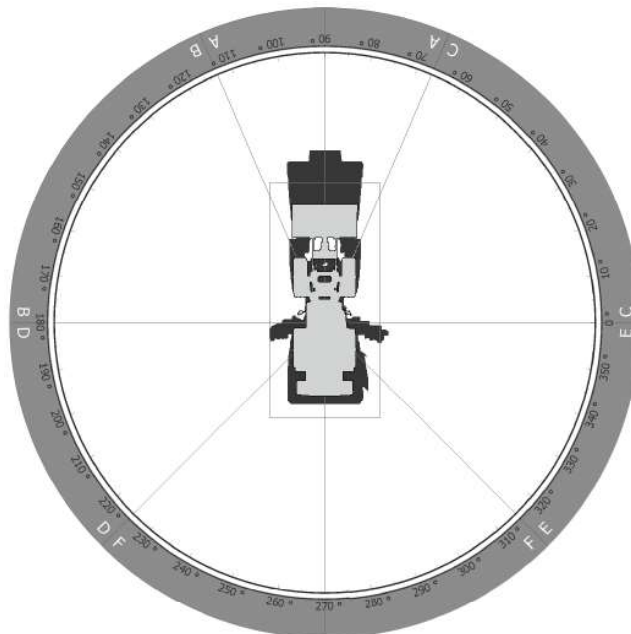

< Top view of the machine at ground level visibility with use of optional visual aids >

- ※ The shaded areas indicate the approximate location of areas with significant restricted visibility. (Radius = 12 m / 34 ft)

SAFETY REQUIREMENTS FOR STAGE V ENGINE

This engine meets the following emission regulations;

- United States and Canada : EPA Tier 4 (Final)
- European Union : Stage V

To comply with the above emission regulations, please make sure to observe the operation methods and safety requirements listed in this manual.

- ▲ It is unlawful to tamper with or remove any component of the aftertreatment system. It is also unlawful to use a Diesel Exhaust Fluid (DEF) that does not meet the specifications provided or to operate the vehicle/equipment with no Diesel Exhaust Fluid (DEF).

Safety Requirements for DEF and SCR system

The DEF/AdBlue® level gauge should be checked daily, and if the DEF/AdBlue® warning lamp and DEF/AdBlue® fill up warning lamp are activated, it is recommended that the DEF/AdBlue® is filled completely full in order to correct any fault conditions.

Allowing the DEF tank to become empty will cause the aftertreatment DEF dosing system to lose prime. A loss of prime condition may cause fault codes to become active.

If corrective action is not taken within 30 minutes of the Check engine lamp illumination, the engine will enter the final derate level, which may include throttle lock or engine shutdown with possible re-start limitations.

- ※ It is recommended that the DEF tank be filled completely full of DEF in order to correct any fault conditions.

If the engine has been shut down or has idled for an extended period of time after the DEF gauge indicates empty, the Stop engine lamp will also be illuminated along with the flashing DEF lamp and illuminated Check engine lamp. The engine will enter the final derate level which may include low idle lock or engine shutdown with restart limitations.

- ※ In order to remove the final derate, the DEF tank must be filled to above 10 percent gauge reading. It is recommended that the DEF tank be filled completely full of DEF in order to correct any fault conditions.

- ※ The use of DEF/AdBlue® meeting ISO 22241-1 is required. There is no acceptable substitute. Some locations may reference the DIN 70070 standard. Diesel Exhaust Fluid specification limits of this standard are identical to ISO 22241-1.

Safety Requirements for fuel

The engine has been optimized for use with an exhaust aftertreatment to meet the Tier 4 Final/ Stage V off-highway emissions regulations. It must operate on Ultra-Low Sulfur Diesel (ULSD) with a maximum sulfur content of 15 parts per million (ppm) in the United States and 10 ppm in the European Union. Failure to do so can permanently damage engine and aftertreatment systems within a short period of time. This damage could cause the engine to become inoperable and affect the warranty coverage on the engine.

Ultra-low sulfur diesel fuel, also defined by ASTM S-15, is defined as diesel fuel not exceeding 0.0015 (15 ppm) mass percent sulfur content. There is no acceptable substitute.

At operating temperatures below 0°C [32° F], acceptable performance can be obtained by using blends of number 2D and number 1D.

The following chart lists acceptable fuel types for this engine.

Number 1D Diesel	Number 2D Diesel	Number 1K Kerosene	Jet-A	Jet-A1	JP-5	JP-8	Jet-B	JP-4	CITE
OK	OK	Not OK	Not OK	Not OK	Not OK	Not OK	Not OK	Not OK	Not OK
48-34	40-24	50-35	51-37	51-37	48-36	51-37	57-45	57-45	57-45

- ① Any adjustment to compensate for reduced performance with a fuel system using alternate fuel is not warrantable.
 - ② Winter blend fuels, such as those found at commercial fuel dispensing outlets, are combinations of number 1D and number 2D diesel fuel, and are acceptable.
 - ③ British thermal unit (BTU) content/Degree API Gravity – Low American Petroleum Institute (API) gravity fuels have a higher thermal energy content (BTU). As a general rule, there is a 3 to 5 percent decrease in BTU content for every 10 degree increase in API gravity; there is no also a 0.7 degree API gravity increase with an increase in fuel temperature. This decrease in energy content equates roughly to the same percentage of power loss. Use of fuels with higher API gravity will cause higher than normal fuel consumption.
- ※ Recommend that the cetane number of diesel fuel be a minimum of 45 for engines that are expected to operate at temperatures below 0°C [32°F] and a minimum of 42 for engines that are operated at temperatures above 0°C [32°F].
 - ※ The use of diesel fuel with a lower than recommended cetane number can cause hard starting, instability, and excessive white smoke. To maintain satisfactory operation at low ambient temperatures, it is important to specify diesel fuel of the collect cetane number.

Safety Requirements for the lubrication oil

The use of a high-quality Society of Automotive Engineers (SAE) 15W-40 heavy-duty engine oil is required such as Valvoline Premium Blue™ (USA) or Valvoline Premium Blue® Extra (International), which meets or exceeds Cummins Engineering Standard (CES) 20081 and the American Petroleum Institute (API) performance classification CJ-4.

To determine if the lubricating oil meets CES 20081, review the label on the back of the lubricating oil bottle for the CES 20081 reference. If acquiring the lubricating oil in bulk, contact the supplier for the lubricating oil specifications and confirm that the oil meets CES 20081.

Also located on the lubricating oil bottle is the API service symbol, which is shown in the accompanying illustration. The upper half of the symbol displays the appropriate oil categories. The center section identifies the SAE oil viscosity grade. The table below shows how the CES compares to the API classification.

CES	API	Comments
CES-20081	CJ-4/SL	Minimum classification required

※ CK-4 should be applied to satisfy 1000/800 hours of oil and oil/fuel filter change interval.

Safety Requirements for the additives

New Engine Break-in Oils

※ Special break-in engine lubricating oils are not recommended for new or rebuilt engines. Use the same type of oil during the break-in period as is to be used in normal operation.

AfterMarket Oil Additive Usage

※ The use of aftermarket oil additives is not recommended. Present high-quality fully additive engine lubricating oils are very sophisticated, with precise amounts of additives blended into the lubricating oil to meet stringent requirements. These oils meet performance characteristics that conform to the lubricant industry standards. Aftermarket lubricating oil additives are not necessary to enhance engine oil performance, and in some cases, can reduce the finished oil's ability to protect the engine.

2. SPECIFICATIONS

1. MAJOR COMPONENTS

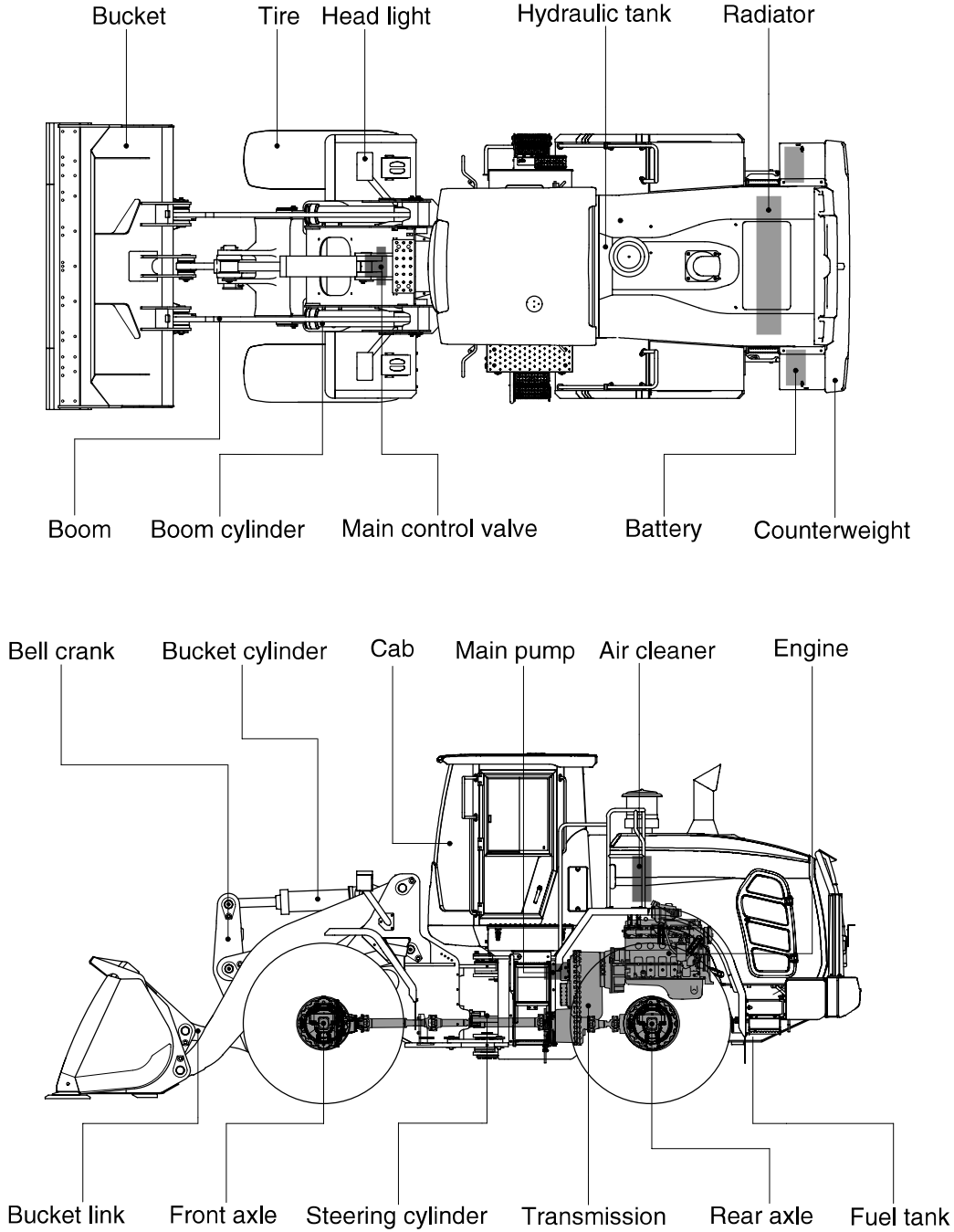

960A2SE01

2. SPECIFICATIONS

1) WITH BOLT-ON CUTTING EDGE TYPE BUCKET (HL960A / HL960A HD)

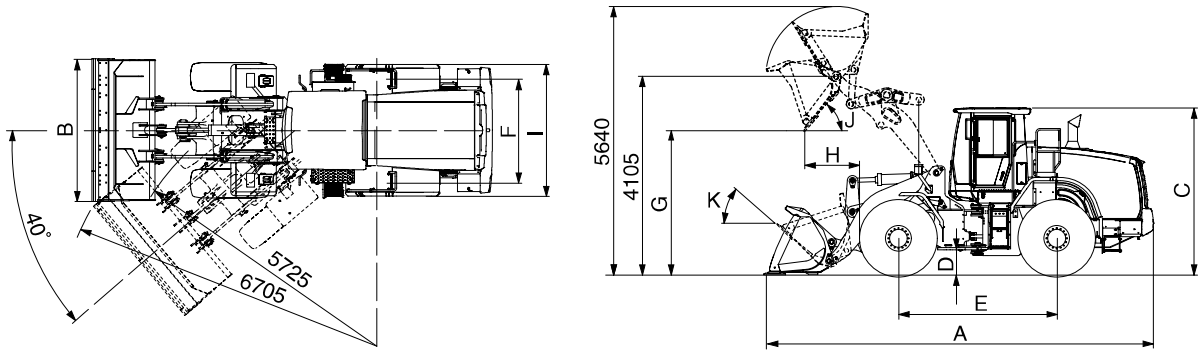

960A2SE03

Description		Unit	Specification	
Operating weight (HL960A / HL960A HD)		kg (lb)	19200 (42330) / 19450 (42880)	
Bucket capacity	Struck	m ³ (yd ³)	2.9 (3.8)	
	Heaped		3.3 (4.3)	
Overall length	A	mm (ft-in)	8140 (26' 8")	
Overall width	B		2900 (9' 6")	
Overall height	C		3450 (11' 4")	
Ground clearance	D		410 (1' 4")	
Wheelbase	E		3300 (10' 10")	
Tread	F		2160 (7' 1")	
Dump clearance at 45°	G		2935 (9' 8")	
Dump reach (full lift)	H		1285 (4' 2")	
Width over tires	I		2770 (9' 1")	
Dump angle	J		degree (°)	50
Roll back angle (carry position)	K			47
Cycle time	Lift (with load)	sec	5.8	
	Dump (with load)		2.0	
	Lower (empty)		3.6	
Maximum travel speed		km/hr (mph)	39.0 (24.2)	
Braking distance		m (ft-in)	13.3 (43' 8")	
Minimum turning radius (center of outside tire)			5.72 (18' 9")	
Gradeability		degree (°)	30	
Breakout force		kg (lb)	16670 (36750)	
Travel speed	Forward	First gear	6.4 (4.0)	
		Second gear	12.1 (7.5)	
		Third gear	24.5 (15.2)	
		Fourth gear	39.0 (24.2)	
	Reverse	First gear	6.8 (4.2)	
		Second gear	12.8 (7.9)	
Third gear		25.7 (15.9)		

WITH BOLT-ON CUTTING EDGE TYPE BUCKET (HL960A XT / HL960A HD XT)

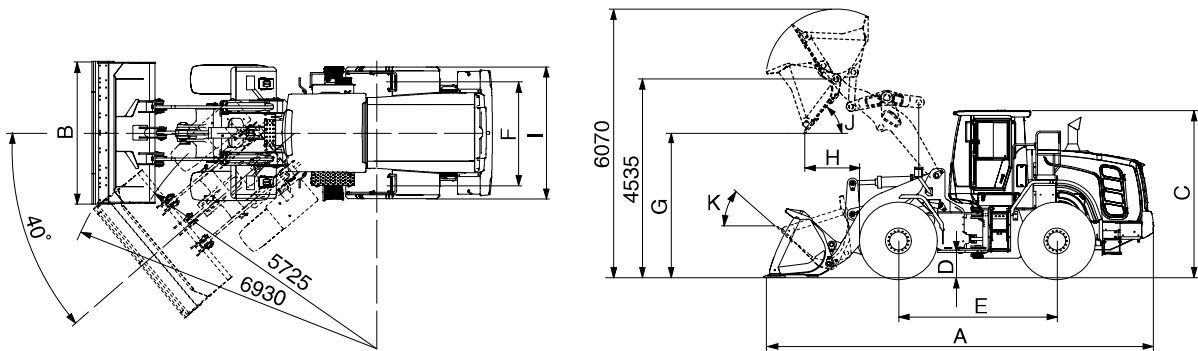

960A2SE03-1

Description		Unit	Specification	
Operating weight (HL960A XT /HL960A HD XT)		kg (lb)	20030 (44160) / 20280 (44710)	
Bucket capacity	Struck	m ³ (yd ³)	2.9 (3.8)	
	Heaped		3.3 (4.3)	
Overall length	A	mm (ft-in)	8695 (28' 6")	
Overall width	B		2900 (9' 6")	
Overall height	C		3450 (11' 4")	
Ground clearance	D		410 (1' 4")	
Wheelbase	E		3300 (10' 10")	
Tread	F		2160 (7' 1")	
Dump clearance at 45°	G		3365 (11' 0")	
Dump reach (full lift)	H		1380 (4' 6")	
Width over tires	I		2770 (9' 1")	
Dump angle	J		degree (°)	50
Roll back angle (carry position)	K			48
Cycle time	Lift (with load)		sec	5.8
	Dump (with load)			2.0
	Lower (empty)	3.6		
Maximum travel speed		km/hr (mph)	39.0 (24.2)	
Braking distance		m (ft-in)	13.3 (43' 8")	
Minimum turning radius (center of outside tire)			5.72 (18' 9")	
Gradeability		degree (°)	30	
Breakout force		kg (lb)	16430 (36220)	
Travel speed	Forward	First gear	6.4 (4.0)	
		Second gear	12.1 (7.5)	
		Third gear	24.5 (15.2)	
		Fourth gear	39.0 (24.2)	
	Reverse	First gear	6.8 (4.2)	
		Second gear	12.8 (7.9)	
Third gear		25.7 (15.9)		

2) WITH TOOTH TYPE BUCKET (HL960A / HL960A HD)

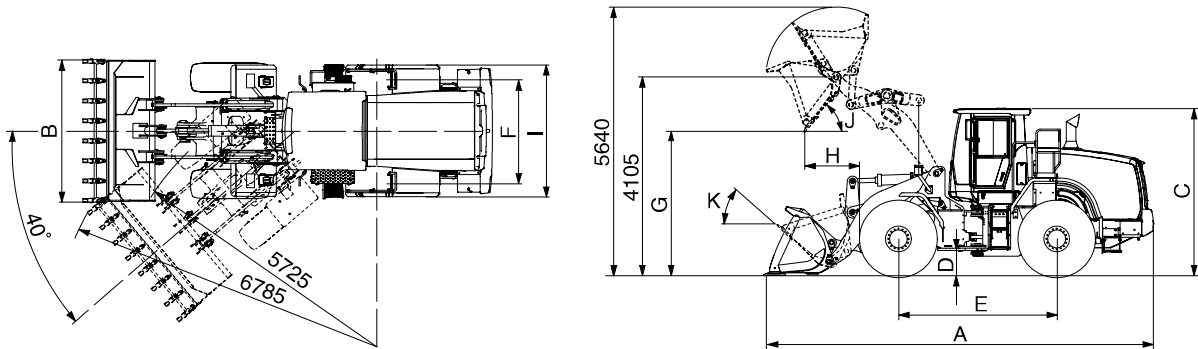

960A2SE02

Description		Unit	Specification	
Operating weight (HL960A / HL960A HD)		kg (lb)	19125 (42160) / 19375 (42710)	
Bucket capacity	Struck	m ³ (yd ³)	2.8 (3.6)	
	Heaped		3.2 (4.2)	
Overall length	A	mm (ft-in)	8290 (27' 2")	
Overall width	B		2950 (9' 8")	
Overall height	C		3450 (11' 4")	
Ground clearance	D		410 (1' 4")	
Wheelbase	E		3300 (10' 10")	
Tread	F		2160 (7' 1")	
Dump clearance at 45°	G		2810 (9' 3")	
Dump reach (full lift)	H		1370 (4' 6")	
Width over tires	I		2770 (9' 1")	
Dump angle	J		degree (°)	50
Roll back angle (carry position)	K			47
Cycle time	Lift (with load)	sec	5.8	
	Dump (with load)		2.0	
	Lower (empty)		3.6	
Maximum travel speed		km/hr (mph)	39.0 (24.2)	
Braking distance		m (ft-in)	13.3 (43' 8")	
Minimum turning radius (center of outside tire)			5.72 (18' 9")	
Gradeability		degree (°)	30	
Breakout force		kg (lb)	17705 (39030)	
Travel speed	Forward	First gear	6.4 (4.0)	
		Second gear	12.1 (7.5)	
		Third gear	24.5 (15.2)	
		Fourth gear	39.0 (24.2)	
	Reverse	First gear	6.8 (4.2)	
		Second gear	12.8 (7.9)	
Third gear		25.7 (15.9)		

WITH TOOTH TYPE BUCKET (HL960 XT / HL960 HD XT)

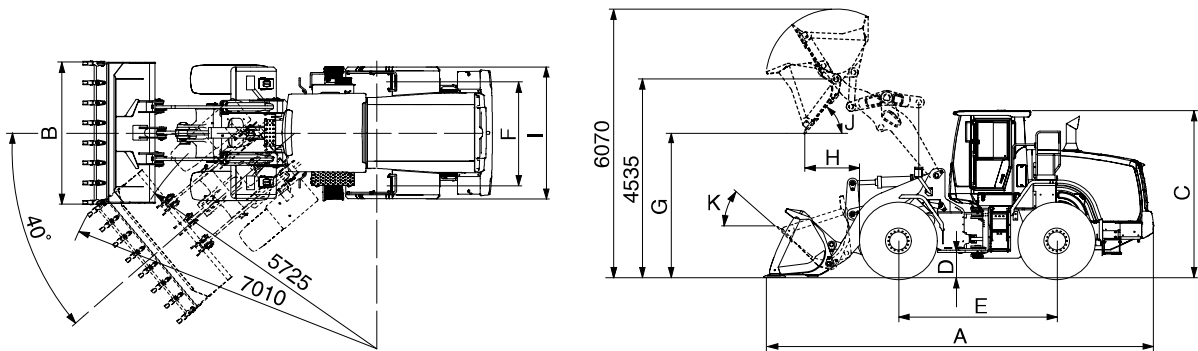

960A2SE02-1

Description		Unit	Specification	
Operating weight (HL960 XT / HL960 HD XT)		kg (lb)	19955 (43990) / 20205 (44540)	
Bucket capacity	Struck	m ³ (yd ³)	2.8 (3.6)	
	Heaped		3.2 (4.2)	
Overall length	A	mm (ft-in)	8845 (29' 0")	
Overall width	B		2950 (9' 8")	
Overall height	C		3450 (11' 4")	
Ground clearance	D		410 (1' 4")	
Wheelbase	E		3300 (10' 10")	
Tread	F		2160 (7' 1")	
Dump clearance at 45°	G		3240 (10' 8")	
Dump reach (full lift)	H		1465 (4' 9")	
Width over tires	I		2770 (9' 1")	
Dump angle	J		degree (°)	50
Roll back angle (carry position)	K			48
Cycle time	Lift (with load)	sec	5.8	
	Dump (with load)		2.0	
	Lower (empty)		3.6	
Maximum travel speed		km/hr (mph)	39.0 (24.2)	
Braking distance		m (ft-in)	13.3 (43' 8")	
Minimum turning radius (center of outside tire)			5.72 (18' 9")	
Gradeability		degree (°)	30	
Breakout force		kg (lb)	17465 (38500)	
Travel speed	Forward	First gear	6.4 (4.0)	
		Second gear	12.1 (7.5)	
		Third gear	24.5 (15.2)	
		Fourth gear	39.0 (24.2)	
	Reverse	First gear	6.8 (4.2)	
		Second gear	12.8 (7.9)	
Third gear		25.7 (15.9)		

3. WEIGHT

Item		kg	lb
Front frame assembly (HL960A / HL960A XT)		1640	3615
Front frame assembly (HL960A HD / HL960A HD XT)		1645	3626
Rear frame assembly		1937	4270
Front fender (LH & RH)		64	141
Counterweight	HL960A / HL960A XT	884/1520	1948/3351
	HL960A HD / HL960A HD XT		
Cab assembly		1048	2310
Engine assembly		534	1177
Transmission assembly (4-speed/5-speed)		558/583	1230/1285
Drive shaft (front)		34	75
Drive shaft (center)		23	51
Drive shaft (rear)		12	26
Front axle (include differential) (HL960A / HL960A XT)		1050	2314
Front axle (include differential) (HL960A HD / HL960A HD XT)		1236	2724
Rear axle (include differential) (HL960A / HL960A XT)		1070	2358
Rear axle (include differential) (HL960A HD / HL960A HD XT)		1450	3197
Tire (23.5 R25, ★ ★, L3)		343	756
Hydraulic tank assembly		186	410
Fuel tank assembly		331	729
Main pump assembly		62	136
Brake pump assembly		11	24
Main control valve (2/3 spool)		90 /105	198/231
Steering valve (priority valve)		5.9	13
Boom assembly	HL960A / HL960A XT	1257/1434	2771/3161
	HL960A HD / HL960A HD XT		
Bell crank assembly		361	795
Bucket link		64	141
3.3 m ³ bucket, with bolt on cutting edge		1843	4063
3.2 m ³ bucket, with tooth		1767	3895
Boom cylinder assembly (LH&RH)		342	754
Bucket cylinder assembly (HL960A / HL960A XT)		163	359
Bucket cylinder assembly (HL960A HD / HL960A HD XT)		181	399
Steering cylinder assembly (LH & RH)		58	128
Seat		80	176
Battery		45	99

4. SPECIFICATION FOR MAJOR COMPONENTS

1) ENGINE

Item	Specification
Model	Cummins B6.7
Type	4-cycle turbocharged, charge air cooled diesel engine
Control type	Electronic control
Cooling method	Water cooling
Number of cylinders and arrangement	6 cylinders, in-line
Firing order	1-5-3-6-2-4
Combustion chamber type	Direct injection type
Cylinder bore × stroke	107 × 124 mm (4.2" × 4.9")
Piston displacement	6700 cc (408 cu in)
Compression ratio	17.3 : 1
Rated horse power (Gross)	225 hp at 2200 rpm
Maximum torque (1300 rpm)	121 kgf·m (875 lbf·ft)
Engine oil quantity	18ℓ (4.8 U.S. gal)
Wet weight	583 kg (1285 lb)
High idling speed	2230 ± 50 rpm
Low idling speed	800 ± 25 rpm
Rated fuel consumption (at rated)	206 g/kW·hr
Starting motor	Melco 90P(24V-5.5kW)
Alternator	Denso, 24V-95Amp
Battery	2 × 12V × 160Ah

2) MAIN PUMP

Item	Specification	
	Steering	Loader
Type	Variable piston pump	
Capacity	74 cc/rev	45 cc/rev
Maximum operating pressure	280 kgf/cm ² (3980 psi)	
Rated oil quantity (at 2200 rpm)	163ℓ/min (43.0 U.S.gpm)	99ℓ/min (26.2 U.S.gpm)
Maximum speed	2230 rpm	

3) FAN AND BRAKE PUMP

Item	Specification
Type	Variable piston pump
Capacity	28 cc/rev
Maximum operating pressure	250 kgf/cm ² (3560 psi)
Rated oil quantity (at 2200 rpm)	62ℓ/min (16.3 U.S.gpm)
Maximum speed	2230 rpm

4) MAIN CONTROL VALVE

Item	Specification
Type	2 spool / 3 spool
Operating method	Hydraulic pilot assist
System pressure	280 kgf/cm ² (3980 psi)
Overload relief valve pressure	340 kgf/cm ² (4840 psi)

5) ELECTRO-HYDRAULIC (INCLUDED IN MCV SIDE)

Item	Specification
Type	Proportional pressure reducing valve
Control current	0~800 mA
Resistance	12 Ω
Normal flow	7.5 lpm (1.98 U.S.gpm)

6) REMOTE CONTROL VALVE (EH TYPE)

Item	Specification
Type	Fingertip
Axle	Single axle for boom, bucket, auxiliary
Operating voltage	4.5~5.5 V
Output signal	0.5~4.5 V (neutral 2.5 V)

7) REMOTE CONTROL VALVE (FNR TYPE)

Item	Specification
Type	Joystick
Axle	Two axle for boom, bucket, roller for auxiliary
Operating type	CAN J1939
Baud rate	500 Kbps

8) CYLINDER

Item	Specification
Boom cylinder	Bore dia×Rod dia×Stroke ∅140×∅80×765 mm
Bucket cylinder	Bore dia×Rod dia×Stroke ∅160×∅85×530 mm
Steering cylinder	Bore dia×Rod dia×Stroke ∅ 80×∅45×424 mm

9) DYNAMIC POWER TRANSMISSION DEVICES

Item	Specification		
4-speed transmission (std)	Model	ZF 4WG 210	
	Type	Converter	Single-stage, single-phase
		Transmission	Full-automatic power shift
	Gear shift	Forward fourth gear, reverse third gear	
	Control	Electrical single lever type, kick-down system	
	Travel speed	Forward 1/2/3/4 : 6.4 / 12.1 / 24.5 / 39.0 km/hr Reverse 1/2/3 : 6.8/12.8/25.7 km/hr	
5-speed transmission (opt)	Model	ZF 5WG210	
	Type	Converter	Single-stage, double-phase (with lock up clutch)
		Transmission	Full-automatic power shift
	Gear shift	Forward fifth gear, reverse third gear	
	Control	Electrical single lever type, kick-down system	
	Travel speed	Forward 1/2/3/4/5	6.7/11.8/18.2/ 28.4/ 40.0 km/hr
Reverse 1/2/3		7.1/12.5/29.9 km/hr	
Axle	Drive devices	4-wheel drive	
	Front	Front fixed location	
	Rear	Oscillation ±12° of center pin-loaded	
Wheels	Tires	23.5 R25, ★★, L3)	
Brakes	Travel	Four-wheel, wet-disc type, full hydraulic	
	Parking	Spring applied, hydraulic released brake on transmission	
Steering	Type	Full hydraulic, articulated	
	Steering angle	40° to both right and left angle, respectively	
	Relief pressure	210 kgf/cm ² (2990 psi)	

3. CONTROL DEVICES

1. CAB DEVICES

1) The ergonomically designed console box and suspension type seat provide the operator with comfort.

2) ELECTRONIC MONITOR SYSTEM

(1) The centralized electronic monitor system allows the status and conditions of the machine to be monitored at a glance.

(2) It is equipped with a safety warning system for early detection of machine malfunction.

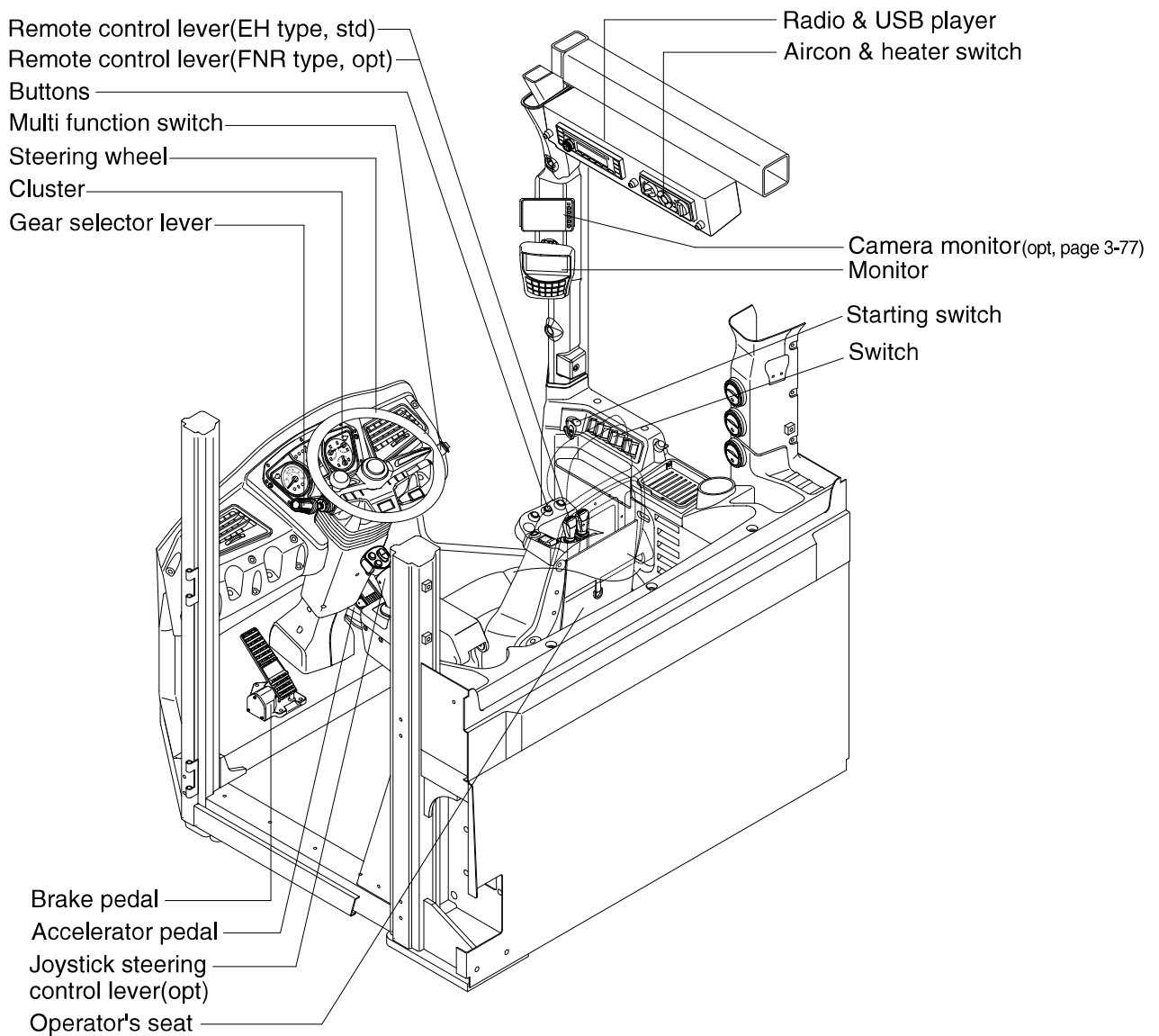

960A3CD01

2. CLUSTER

1) STRUCTURE

The cluster consists of gauges, lamps and LCD as shown below, to warn the operator in case of abnormal machine operation or conditions for the appropriate operation and inspection.

- Gauges : Indicate operating status of the machine.
- Warning lamps : Indicate abnormality of the machine.
- Pilot lamps : Indicate operating status of the machine.
- LCD : Indicates selected the driving speed and direction.

※ The cluster installed on this machine does not entirely guarantee the condition of the machine. Daily inspection should be performed according to chapter 6, MAINTENANCE.

※ When the cluster provides a warning immediately check the problem, and perform the required action.

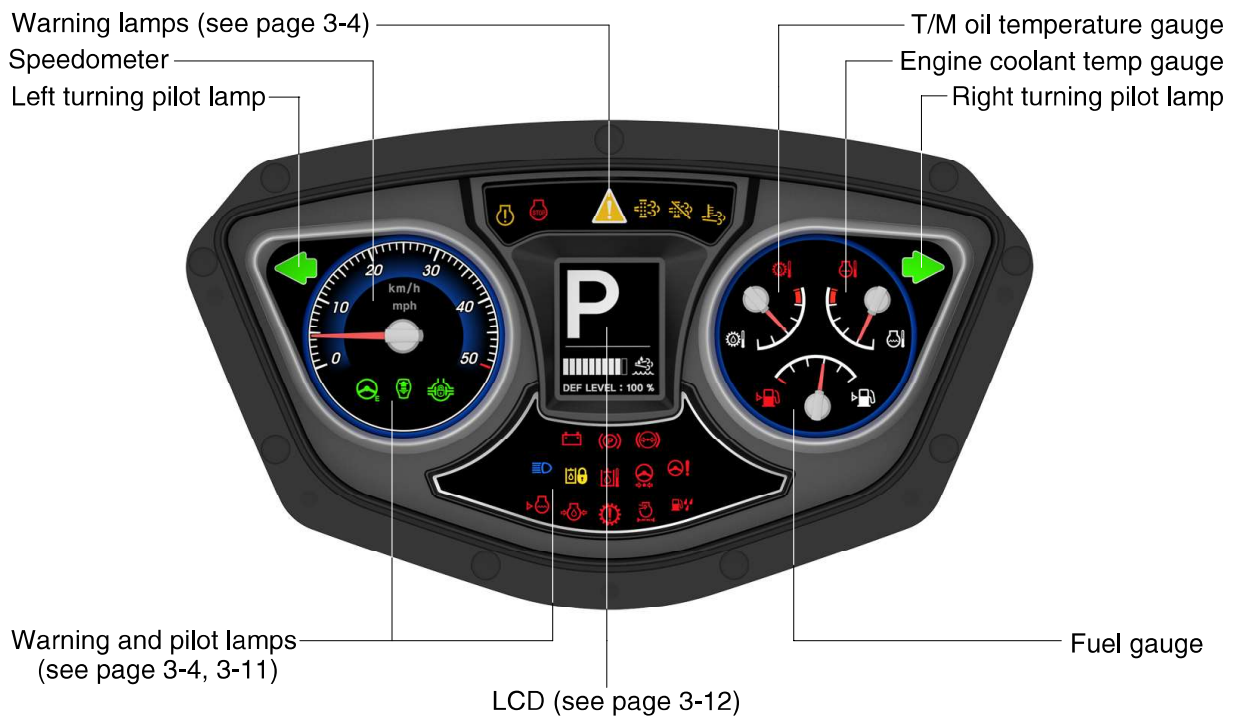

960A3CD02

2) GAUGE

(1) Speedometer

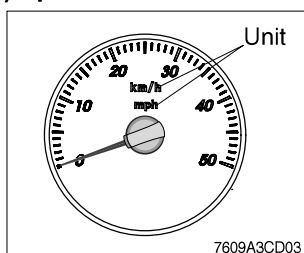

- ① The speedometer displays the speed of machine in mph and km/h.
- ※ The unit (km/h or mph) can be set by the display set up menu of the monitor and selected unit is displayed. Refer to page 3-33.

(2) Fuel gauge

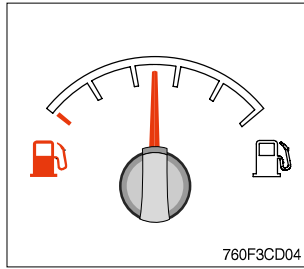

- ① This gauge indicates the amount of fuel in the fuel tank.
 - ② Fill the fuel when the indicator moves red range or  lamp blinks in red, refuel as soon as possible to avoid running out of fuel.
- ※ If the gauge indicates red range even though the machine is on the normal condition, check the electric device as that can be caused by the poor connection of electricity or sensor.

(3) Engine coolant temperature gauge

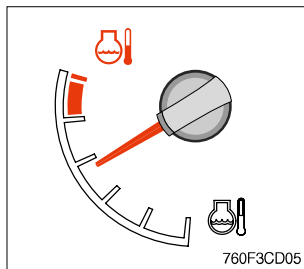

- ① This gauge indicates the temperature of coolant.
 - White range : 40~105°C (104~221°F)
 - Red range : Above 105°C (221°F)
 - ② If the indicator is in the red range or  lamp blinks in red, turn OFF the engine and check the radiator and engine.
- ※ If the gauge indicates red range even though the machine is on the normal condition, check the electric device as that can be caused by the poor connection of electricity or sensor.

(4) Transmission oil temperature gauge

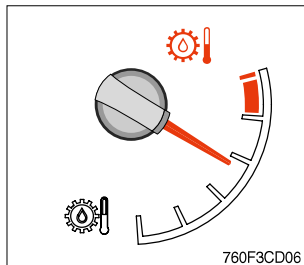

- ① This gauge indicates the temperature of transmission oil.
 - White range : 40~107°C (104~225°F)
 - Red range : Above 107°C (225°F)
 - ② If the indicator is in the red range or  lamp blinks in red, it means the transmission is overheated. Be careful that the indicator does not move into the red range.
- ※ If the gauge indicates red range even though the machine is on the normal condition, check the electric device as that can be caused by the poor connection of electricity or sensor.

3) WARNING LAMPS

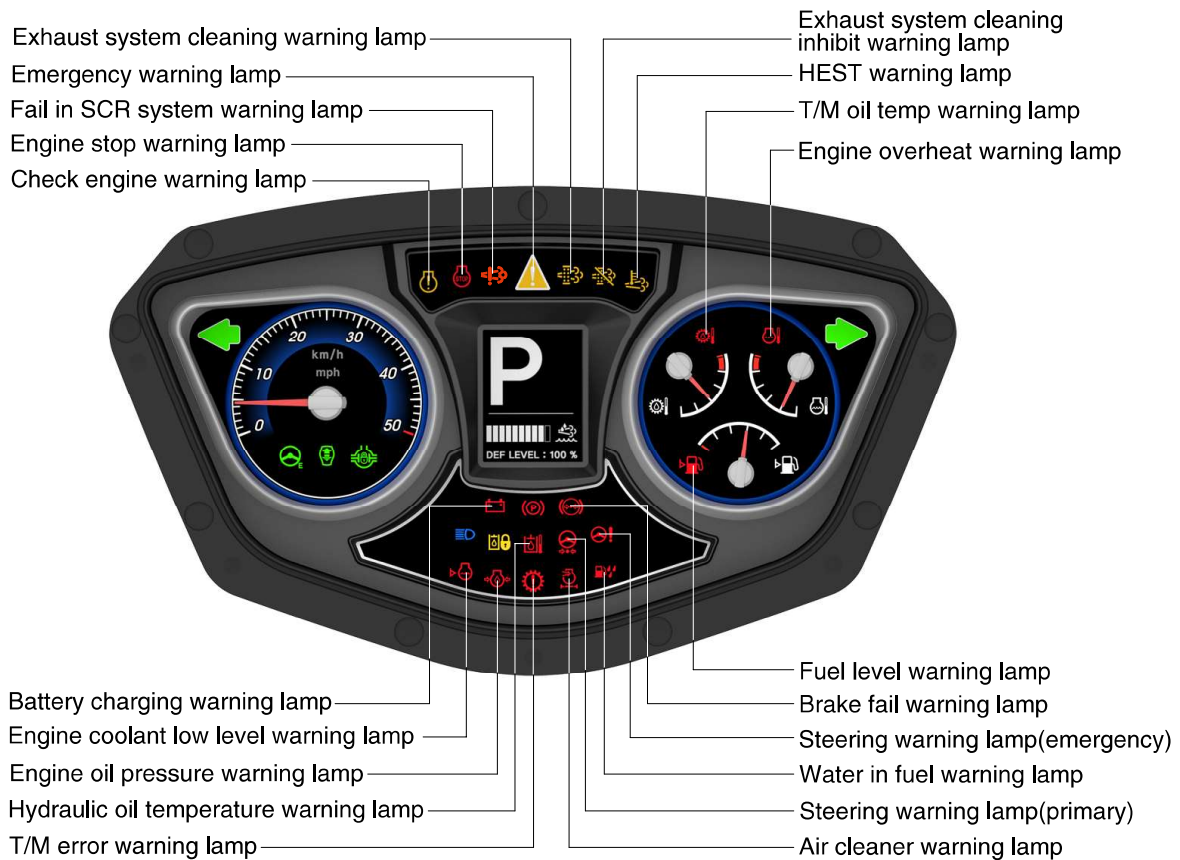

960A3CD09A

(1) Emergency warning lamp

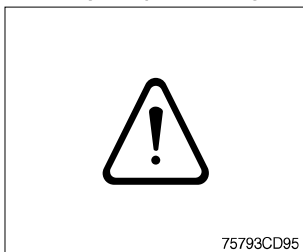

- ① This lamp blinks when each of the below warnings is happened.
 - Warning lamps light ON
 - MCU input voltage abnormal
 - Monitor communication data error
 - Engine ECM and TCU communication data error
- ② When this warning lamp blinks, machine must be checked and service immediately.

(2) Engine overheat warning lamp

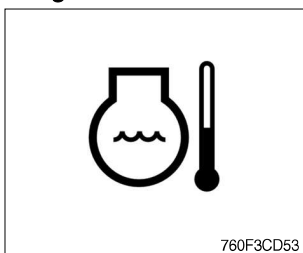

- ① This lamp is turned ON when the temperature of coolant is over the normal temperature (105°C, 221°F).
- ② Check the cooling system when the lamp is ON.

(3) Transmission oil temperature warning lamp

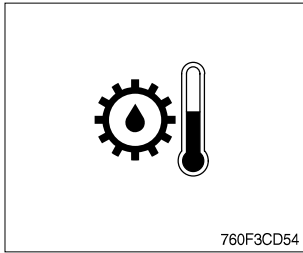

- ① This lamp is turned ON when the temperature of transmission oil is over the normal temperature (107°C, 225°F).
- ② When this lamp lights up during operation, stop the engine and check the machine.

(4) Hydraulic oil temperature warning lamp

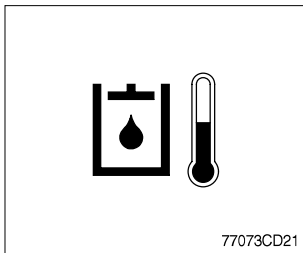

- ① This warning lamp operates and the buzzer sounds when the temperature of hydraulic oil is over 106°C (223°F).
 - ② Check the hydraulic oil level when the lamp is turned ON and the buzzer sounds.
 - ③ Check for debris between oil cooler and radiator.
- ※ If you want to stop buzzer sound, just touch the  icon.

(5) Fuel level warning lamp

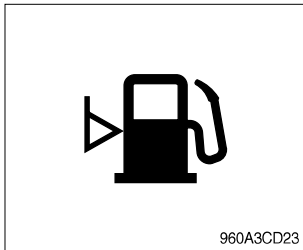

- ① This warning lamp lights ON when the fuel level is low. Refuel the machine as soon as possible.

(6) Transmission error warning lamp

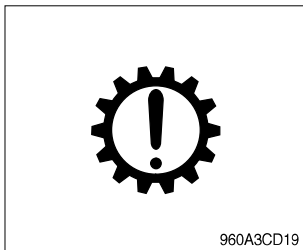

- ① This lamp lights ON and the LCD display show the error codes when an error occurs in the transmission.
 - ② Immediately pull the machine to a convenient stop. Stop the engine. Investigate the cause.
- ※ Consult a HYUNDAI dealer to investigate the cause.
※ Do not operate until the cause has been corrected.

(7) Air cleaner warning lamp

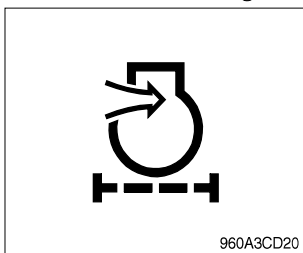

- ① This lamp lights ON and the buzzer sounds when the filter of air cleaner is clogged.
 - ② When the air cleaner warning lamp is ON and the buzzer sounds, check and clean the primary element.
- ※ If you want to stop buzzer sound, just touch the  icon.
※ The primary element should be replaced if the warning lamp is ON after installation of a clean primary element.
※ Replace the primary element after 4 times cleanings.

(8) Engine oil pressure warning lamp

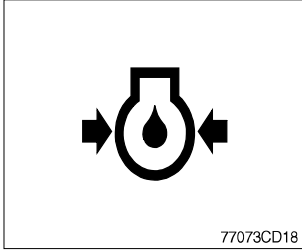

- ① This lamp is comes ON and the buzzer sounds after starting the engine because of the low engine oil pressure.
 - ② If the lamp comes ON and the buzzer sounds during engine operation, shut OFF engine immediately. Check engine oil level.
- ※ If you want to stop buzzer sound, just touch the  icon.

(9) Steering warning lamp

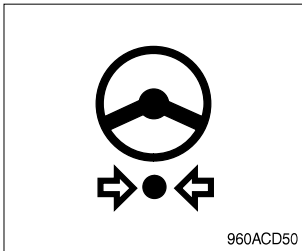

① Primary

This lamp indicates that the primary steering has failed. When the indicator comes ON and the action alarm sounds, steer the machine immediately to a convenient location and stop the machine. Stop the engine and investigate the cause.

- ※ If you want to stop buzzer sound, just touch the  icon.
- ※ Do not operate the machine until the cause has been corrected.





② Emergency

This lamp indicates the emergency steering system is active.

- ※ Immediately pull the machine to a convenient stop and stop the engine.
- ※ The emergency steering system can be manually tested. Refer to page 3-45.

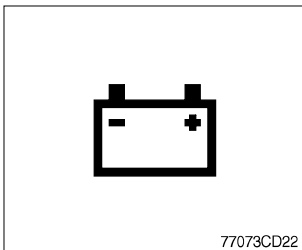
(10) Battery charging warning lamp



- ① This lamp is ON and the buzzer sounds when key ON, it is turned OFF after starting the engine.
 - ② Check the battery charging circuit when this lamp comes ON and the buzzer sounds, during engine operation.
- ※ If you want to stop buzzer sound, just touch the  icon.

(11) Brake fail warning lamp

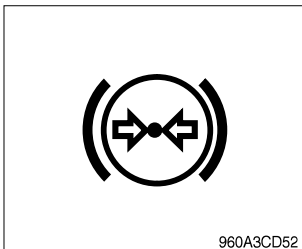

- ① The lamp lights ON and the buzzer sounds when the oil pressure of service brake drops below the normal range.
 - ② When the lamp is ON and the buzzer sounds, stop the engine and check for its cause.
- ※ If you want to stop buzzer sound, just touch the  icon.
- ※ Do not operate until any problems are corrected.

(12) Check engine warning lamp

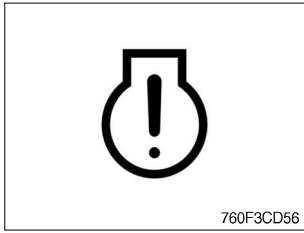

- ① This lamp lights ON and the buzzer sounds when the communication between MCU and engine ECM on the engine is abnormal, or if the cluster received specific fault code from engine ECM.
 - ② Check the communication line between them.
If the communication line is OK, then check the fault codes on the monitor.
- ※ If you want to stop buzzer sound, just touch the  icon.

(13) Engine stop warning lamp

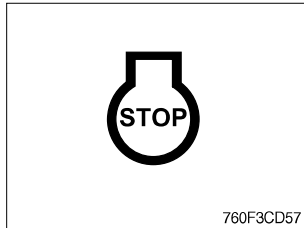

- ① This warning lamp pops up and the buzzer sounds when 30 minutes elapsed with empty condition of the DEF/AdBlue® tank, stop the engine immediately and check the DEF/AdBlue® tank.
- ② Fill the DEF/AdBlue® immediately in the DEF/AdBlue® tank.
※ Refer to page 3-10.
- ③ This lamp lights ON when the stationary exhaust system cleaning is not performed.
※ Refer to page 3-8.
※ Please contact your Hyundai service center or local dealer.
※ "Engine shutdown" cluster message up when the exhaust gas temperature reaches above 800 °C.

(14) Engine coolant low level warning lamp

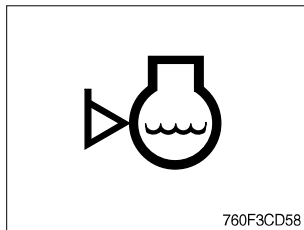

- ① This warning lamp lights ON when the level of coolant is low.
- ② Fill the coolant immediately when the lamp is ON.

(15) Water in fuel warning lamp

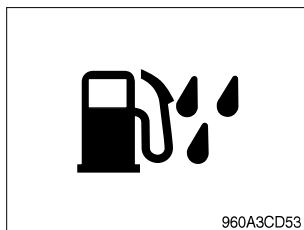

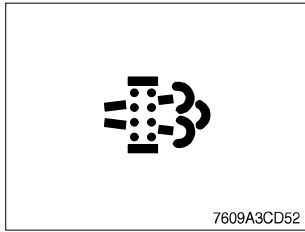

- ① This warning lamp lights ON when the water separator is full of water or malfunctioning.
※ When this lamp lights ON, stop the machine and spill water out of the separator.

(16) Exhaust system cleaning warning lamp



① This warning lamp lights ON or blinks when the exhaust system cleaning is needed as table below.

Warning lamp			Description
Exhaust	Check engine	Stop engine	
			
Off	Off	Off	· Automatic exhaust system cleaning
Blink	Off	Off	· The status of a manual (stationary) exhaust system cleaning when the exhaust system cleaning switch has been activated. * Refer to page 3-9.
On	On	Off	· The aftertreatment exhaust system needs to be cleaned immediately. · Engine power will be reduced automatically if action is not taken. * The exhaust system cleaning can be accomplished by : - Changing to more challenging duty cycle. - Performing a manual exhaust system cleaning.
On	On	On	· These lamps will be ON when a stationary (manual) exhaust system cleaning is not performed. · Stop the engine immediately. · Please contact your Hyundai service center or local dealer.

(17) Exhaust system cleaning inhibit warning lamp

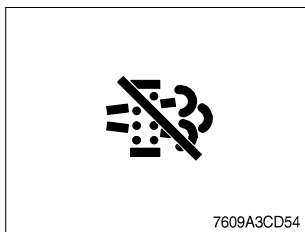

① This warning lamp indicates, when illuminated, the exhaust system cleaning switch is pushed inhibit position, therefore automatic and manual exhaust system cleaning can not occur.
* **Refer to the page 3-46 for the exhaust system cleaning switch.**

※ **Manual exhaust system cleaning**

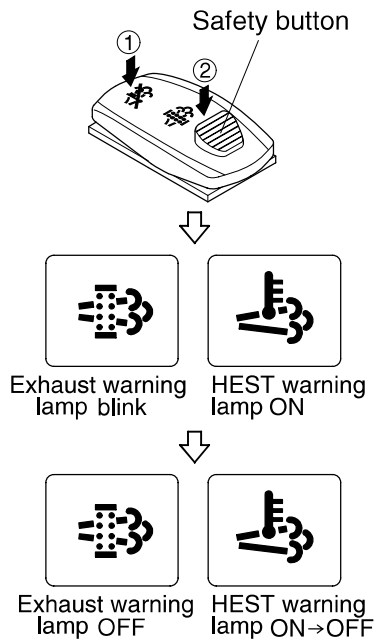

9753CD129A

※ **Manual exhaust system cleaning applies if the machine is in a fireproof area.**

※ **To stop a manual exhaust system cleaning before it has completed, set to the exhaust system cleaning switch to the inhibit position or turn OFF the engine.**

① Stop and park the machine.

② Pull the safety button and push the switch to position ② to initiate the manual exhaust system cleaning.

※ **Refer to the page 3-46 for the exhaust system cleaning switch operation.**

※ **The engine speed may increase to 950~1050 rpm and exhaust system cleaning begins and it will take approximately 20~30 minutes.**

③ The exhaust system cleaning warning lamp will blink and HEST warning lamp will light ON during the exhaust system cleaning is operating.

④ The exhaust system cleaning and/or HEST warning lamp will light OFF when the exhaust system cleaning is completed.

(18) **HEST (High exhaust system temperature) warning lamp**

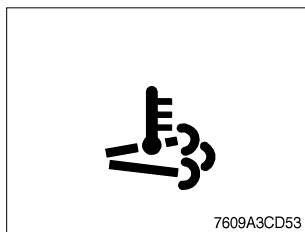

① This warning lamp indicates, when illuminated, that exhaust temperatures are high due to exhaust system cleaning.

② The lamp will also illuminate during a manual exhaust system cleaning.

③ When this lamp is illuminated, be sure the exhaust pipe outlet is not directed at any surface or material that can melt, burn, or explode.

▲ When this lamp is illuminated, the exhaust gas temperature could reach 800°C [1500°F], which is hot enough to ignite or melt common materials, and to burn people.

※ **The lamp does not signify the need for any kind of equipment or engine service; It merely alerts the equipment operator to high exhaust temperatures. It will be common for the lamp to illuminate on and off during normal equipment operation as the engine completes exhaust system cleaning.**

(19) DEF/AdBlue® level warning lamp

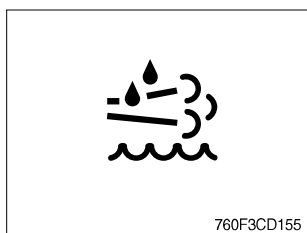

① This warning lamp indicates when ON or blinking, that the DEF/AdBlue® level is low as table below.

※ It is recommended that the DEF/AdBlue® tank be filled completely full of the DEF/AdBlue® in order to correct any fault conditions.

Warning lamp				Description
Fail in SCR system	DEF/AdBlue® level	Check engine	Stop engine	
On	On	Off	Off	<ul style="list-style-type: none"> The DEF/AdBlue® level has fallen below the initial warning level (10%).
On	On	On	Off	<ul style="list-style-type: none"> The DEF/AdBlue® level has fallen below the initial derate level (2.5%). The engine power will be limited automatically.
On	Blink	On	On	<ul style="list-style-type: none"> This is happened when 30 minutes elapsed with empty conditions (0%) of the DEF/AdBlue® tank. The engine will enter the final derate level which may include low idle lock or engine shutdown with restart limitations. In order to remove the final derate, the DEF/AdBlue® tank must be filled to above 10 percent gauge reading.

(20) Fail in SCR system warning lamp

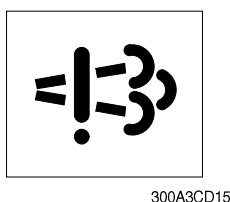

① This warning lamp indicates there are faults related to SCR system.

② The lamp lights ON when each of the below warnings is happened.

- Low DEF/AdBlue® level
- Poor quality of DEF/AdBlue®
- Tempering or malfunction in the aftertreatment system

③ Once the lamp lights ON, the engine will derate shortly.

※ Please contact your Hyundai service center or local dealer.

4) PILOT LAMPS

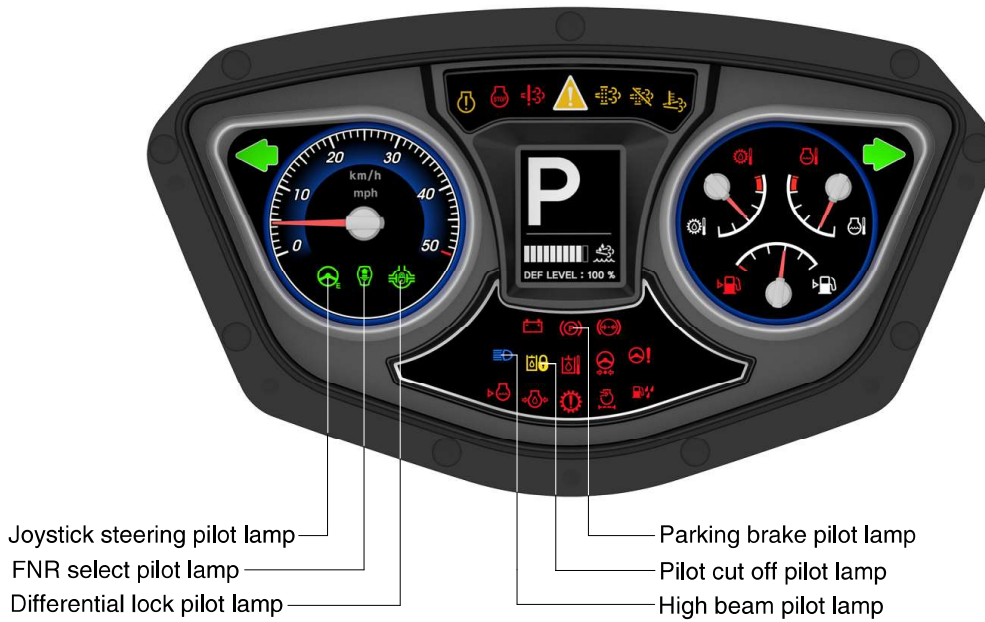

960A3CD10

(1) High beam pilot lamp

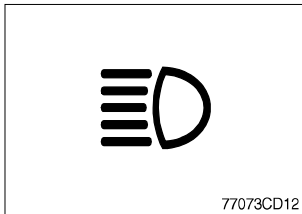

- ① This lamp works when the illuminating direction is upward.
- ② This lamp comes ON when the dimmer switch is operated, e.g., when passing another vehicle.

(2) Parking brake pilot lamp

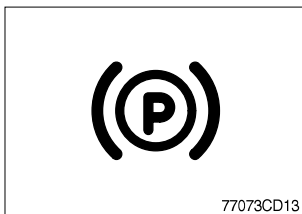

- ① When the parking brake is actuated, the lamp lights ON.
- ※ Check the lamp is OFF before driving.

(3) FNR select pilot lamp (option)

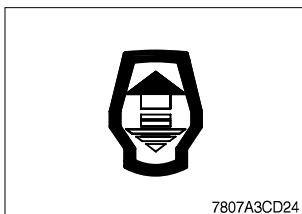

- ① The lamp comes ON when FNR select button on the optional FNR remote control lever is pressed.
- ※ Refer to page 3-47.

(4) Joystick steering pilot lamp (option)



- ① This lamp lights ON when joystick steering is activated. It is then possible to steer the machine and select gears from the armrest to the left of the operator's seat.
- ※ Refer to page 3-51.

(5) Differential lock pilot lamp (option)

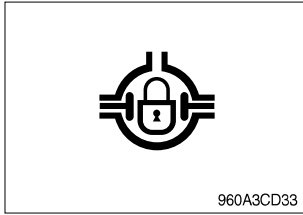

- ① This lamp lights ON when the differential lock function is operating.
 ※ Refer to page 3-45.

(6) Pilot cut off pilot lamp

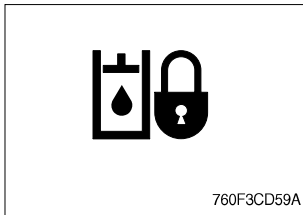

- ① This lamp lights ON when the pilot cut off switch is pressed.
 ※ Refer to page 3-45.

5) LCD

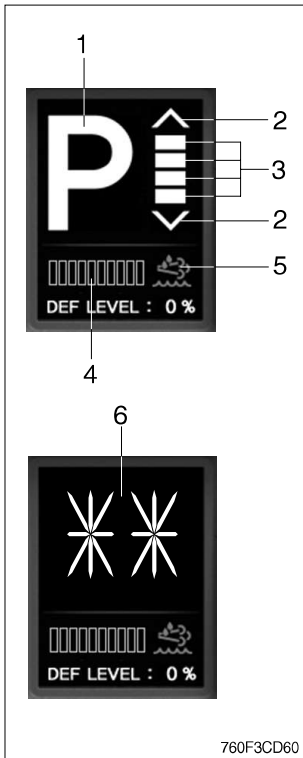

(1) The LCD can be used with the gear selector.

It indicates speed, driving direction, DEF/AdBlue® level and transmission warning.

No	Symbol	Meaning	Remark																
1	△ · ▽ · N	Actual gear display	Forward, reverse, neutral																
	1, 2, 3, 4, 5		Actual gear																
	P		Parking brake mode active																
2	^ , v	Forward, reverse	<table style="display: inline-table; vertical-align: middle;"> <tr> <td style="text-align: center;">^</td> <td>FWD 1</td> <td style="text-align: center;">v</td> <td>REV 1</td> </tr> <tr> <td style="text-align: center;">-</td> <td></td> <td style="text-align: center;">-</td> <td></td> </tr> <tr> <td style="text-align: center;">-</td> <td></td> <td style="text-align: center;">-</td> <td></td> </tr> <tr> <td style="text-align: center;">-</td> <td>FWD 5</td> <td style="text-align: center;">-</td> <td>REV 5</td> </tr> </table>	^	FWD 1	v	REV 1	-		-		-		-		-	FWD 5	-	REV 5
^	FWD 1	v	REV 1																
-		-																	
-		-																	
-	FWD 5	-	REV 5																
3	≡	Gear range display																	
4		DEF/AdBlue® level	Display the amount of liquid in the DEF/AdBlue® tank																
5		DEF/AdBlue® level warning lamp	Fill the DEF/AdBlue® when the lamp ON or blinks in red. - ON : DEF/AdBlue® level 5~10% - Blink : DEF/AdBlue® level below 5% ※ If the lamp ON or blinks in red even though the machine is on the normal condition, check the electric device as that can be caused by the poor connection of electricity or sensor.																
6	LF, LR	Limp home gear	-																
	**	Oil temperature too low, no gear available	Warm up engine / transmission																
	WS	Warning sump temperature	Alternate between WS and actual gear / direction while driving, in neutral only displayed WS if no fault is detected ※ Cool down transmission																
	WT	Warning torque converter temperature	Alternate between WS and actual gear / direction while driving, in neutral only displayed WS if no fault is detected ※ Cool down transmission																

3. MONITOR (7 inch touch screen)

- The monitor is adjustable.
 - Vertical : 30°
 - Horizontal : 15°



760F3CD20-1

1) MAIN DISPLAY

- ※ You can select or set the menu by the switches or touch screen.
- ※ Please refer to switch, page 3-39 for selection and change of menu and input value.
- ※ Display type can be changed by operator. See page 3-34 for details.



760F3CD11-1

- | | | | | | |
|---|---------------|----|-------------------------------|----|------------|
| 1 | Clock | 6 | Machine monitoring | 11 | Engine rpm |
| 2 | Buzzer | 7 | Fuel rate | 12 | Quick menu |
| 3 | Wiper speed | 8 | Engine mode/Operation history | 13 | 10 lamps |
| 4 | Camera screen | 9 | Transmission mode | | |
| 5 | Menu | 10 | ECO gauge | | |

(1) Menu bar

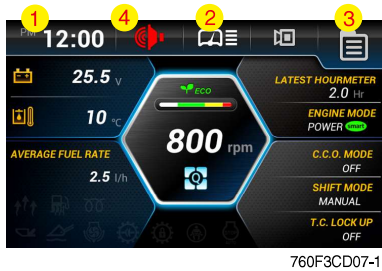

760F3CD07-1

※ In main display, you can move to right side menu by touching each icon.

① Clock setting

Set the time (hour, minute and AM or PM)

② Wiper speed

Set the wiper speed (slow, normal, fast and very fast)

③ Menu

Move to main menu.

④ Buzzer stop

If you want to stop buzzer sound, just touch the



icon.

① Clock setting

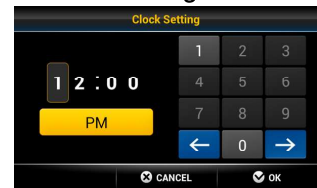

760F3CD07A-1

② Wiper speed

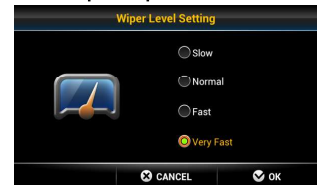

760F3CD07B-1

③ Menu



760F3CD07C-1

④ Buzzer stop



760F3CD07E-1

(2) Change display information

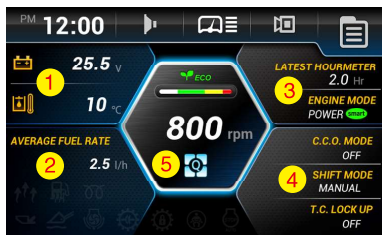

760F3CD08-1

※ In main display, you can check the data and setup what you want by touching each window area or icon.

① Machine monitoring

To display the item in main display, select two items of them.

※ Priority in the machine monitoring display

The priority of the weighing system is the highest.

If the weighing system is selected, the other items are not available.

To display the other items, the weighing system should not be selected.

※ **Weighing system** : see page 3-22.

① Machine monitoring



960A3CD08A

② Fuel rate

- Set average fuel rate or a days fuel used on main display screen.
- Refer to page 3-29.

② Fuel rate



760F3CD08B-1

③ Engine mode and operation history

- Set the engine mode (A).
- Refer to page 3-19.
- Set Hour meter / ODO meter (B).
- Refer to page 3-28.

③ Engine mode



A

960A3CD08D



B

760F3CD08K-1

④ Transmission mode

- Set the clutch cut off (A), shift (B) and torque converter lock up mode (C).
- Refer to page 3-20.

④ Transmission mode

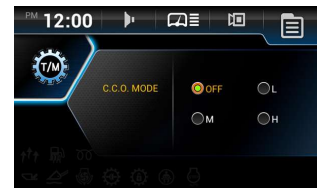

A

760F3CD08C-1



B

760F3CD08L-1

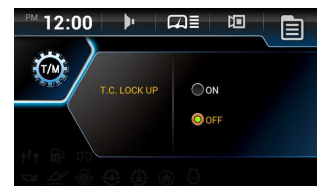

C

760F3CD08M-1

⑤ Quick menu

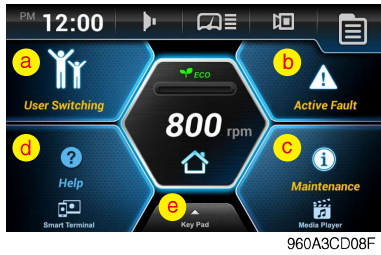

① User switching

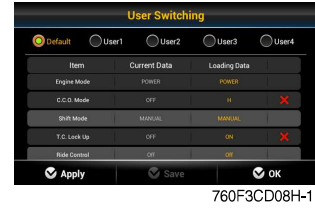

※ Move the quick menu screen by touching .

① User switching

- When multiple users share a machine, it allows users to switch user settings of machine.
- User can apply or save the setting of monitor easily.

② Active fault

- Display the fault code of MCU/ECU/TCU/EHCU.
- Refer to page 3-28.

③ Maintenance

- Elapsed time, change or replace cycle can be changed.
- Refer to page 3-31.

④ Help

- Read the monitor manual as a PDF file on the monitor.

※ Smart terminal

- The menu features a smartphone and operates the miracast.

- ▲ Operation of screen mirroring can be dangerous while driving.
Driver is responsible for accident or other damages.
Operate the screen mirroring while stopping for safety.

② Active fault

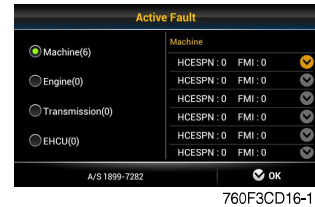

③ Maintenance



④ Help

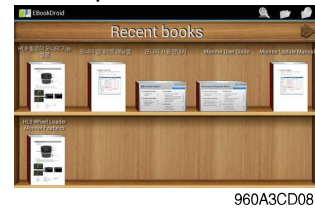

⑤ Virtual keypad

To display the virtual keypad, drag the button () to top of the screen.

※ Refer to the page 3-39 for details.

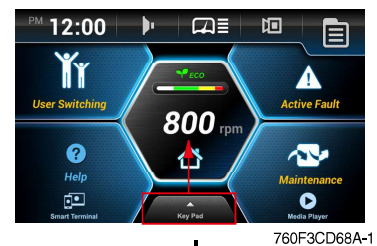

Virtual keypad

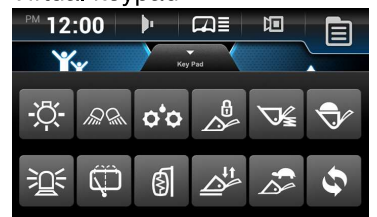

(3) Fault and maintenance warning

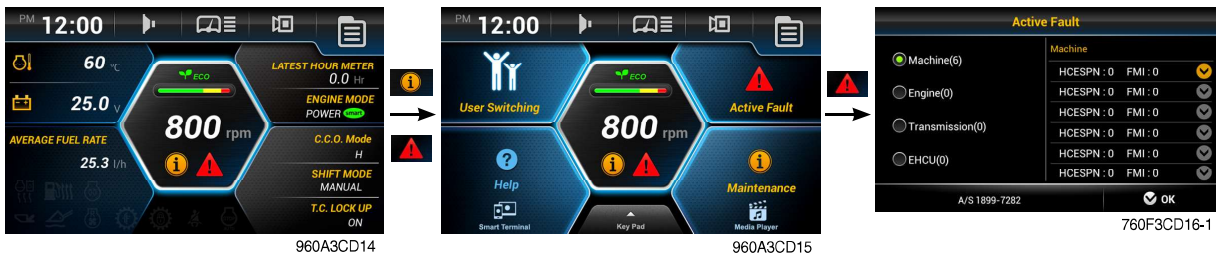

- ① If you touch the warning sign (red icon), move to the quick menu.
- ② You can check the fault message and move the maintenance screen by touching relevant area.



(4) Machine monitoring warning

- ① Warning sign (red icon) will be shown when the temperature of hydraulic oil, cooling water, transmission oil or battery voltage is not normal state.
- ② Case of warning sign

Icon	Description
	Above 106°C of hydraulic oil temperature
	Above 105°C of cooling water temperature
	Above 107°C of transmission oil temperature
	Below 24.5 voltage of battery (for 3 minutes)
	Above 100°C of axle oil temperature (option)

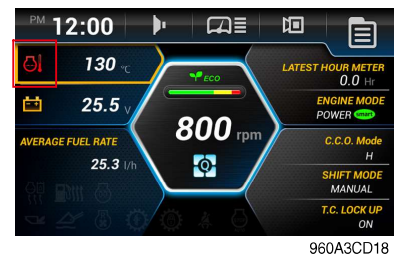

(5) Communication error

- ① MCU could not communicate with monitor over 10 seconds, error message will be show on the screen.

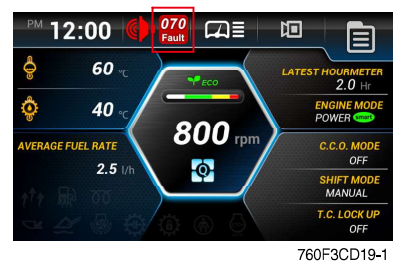

(6) Eco gauge

- ① This gauge indicates the fuel consumption rate and machine load status. So that operators can be careful with fuel economy.
- ② The fuel consumption rate or machine load is high, the segment is increased.
- ③ The color of Eco gauge indicates operation status.
 - White : Idle operation
 - Green : Economy operation
 - Yellow : Non-economy operation at a medium level.
 - Red : Non-economy operation at a high level.

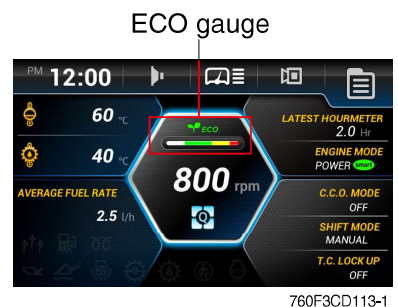

2) MAIN AND SUB MENU

(1) Structure

No	Main menu	Sub menu	Description
1	<p>Mode</p>  <p>760F3CD25A</p>	<p>Engine setting Kick down C.C.O mode Shift mode T.C. lock up Work load</p> <p>Boom/bucket detent mode Bucket priority Auxiliary attach max flow level Soft end stop Speedometer frequency setting Cooling fan reverse mode Wiper level setting Calibration</p> <p>Engine auto shutdown</p>	<p>Engine mode, Engine speed Mode 1 (down/up), Mode 2 (down only) Clutch cut off mode (Off, L, M, H) Transmission shift mode (manual, AL, AN, AH) Torque converter lock up ON/OFF Weighing system, Weighing display, Error detection Boom pressure calibration, Weighing system compensation Boom/bucket detent ON/OFF, Save position Bucket priority ON/OFF Max oil flow level setting Boom up/down, Bucket in/dump ON/OFF Speedometer setting Off, Manual, Automatic Slow, Normal, Fast, Very fast Boom/bucket angle, Boom pressure, Brake pedal sensor, AEB Once, On/Always, Disable, ESL system setting</p>
2	<p>Monitoring</p>  <p>760F3CD25B</p>	<p>Machine monitoring Operation history Fault history Fuel consumption history</p> <p>Machine information</p>	<p>Hyd, Coolant, axle and TM oil temp, Battery voltage Hour meter, ODO meter Active/Logged fault (MCU, ECU, TCU, EHCU, AAVM) General record, Hourly record, Daily record, Mode record, Operation efficiency record TCU, ECM, MCU, RMCU, EHCU, Monitor, Cluster</p>
3	<p>Management</p>  <p>760F3CD25C</p>	<p>Machine security Maintenance Service menu</p> <p>Change A/S phone number Software update Owner menu editing</p>	<p>ESL system setting, Change password Elapsed time, Cycle, Maintenance history Sensor monitoring, Speed limit setting, Weighing system compensation, EHCU I/O information Check and change of contact information Update file in USB memory Owner menu editing, Menu list, Password change</p>
4	<p>Preference</p>  <p>760F3CD25D</p>	<p>Brightness setting Clock setting Unit setting</p> <p>Display style/Language Camera setting AAVM setting</p>	<p>Manual, Automatic Clock setting Temp (° F/° C), Distance (km, mile), Weight (ton, lb), Pressure (bar, Mpa, kgf/m², psi), Volume (l, gal) Type A, Type B, 14 multiple language Active camera, Display order, Reverse mode AAVM camera reverse mode</p>
5	<p>Multimedia</p>  <p>760F3CD25E</p>	<p>Media player Smart terminal</p>	<p>Play video and audio files in USB. Operation of screen mirroring</p>

(2) Mode

① Engine setting mode

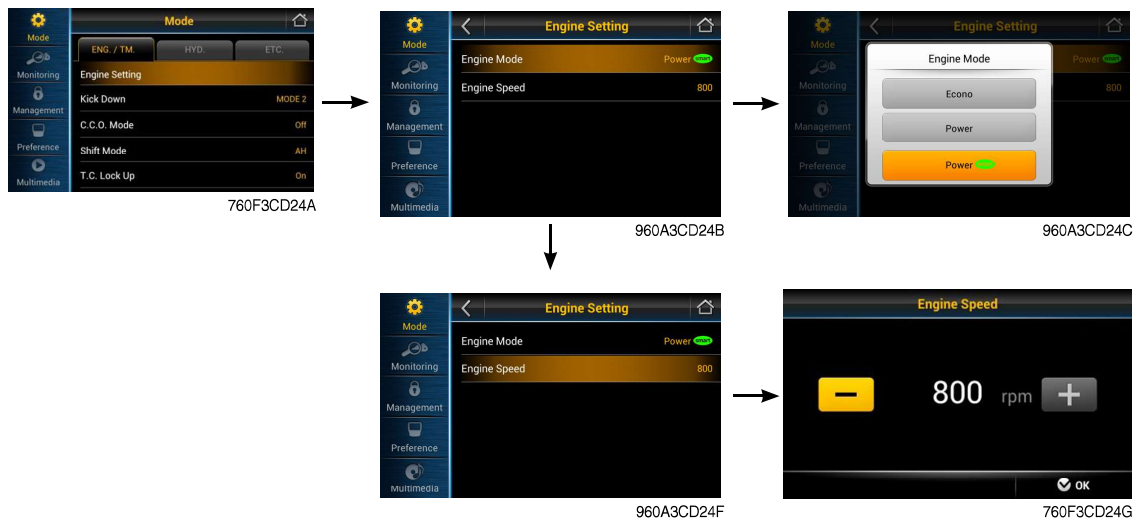

- **Engine mode**

The operator can adjust the machine's performance.

- Econo : Maximum fuel efficiency for general loading.
- Power : Maximum power output for hard digging operation or hill climb.
- Smart power : Fuel efficient operation with same performance as power mode.

- **Engine speed**

Setting engine low idle rpm.

② Kick down mode

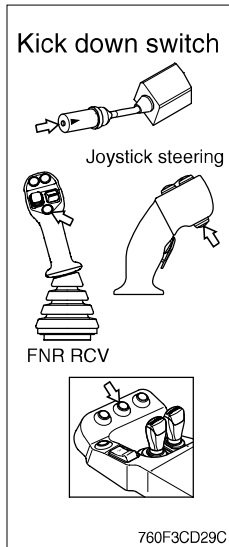
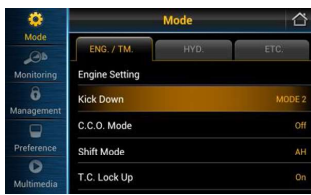

- **Manual mode** (shift mode : manual)
It is effective 2nd speed to 1st speed only and recover to 2nd speed quickly when push the switch one more time.
 - **Automatic mode** (shift mode : AL, AN, AH)
 - **Mode 1** (down/up)
It shifts down quickly from current gear to one step lower speed by pushing the switch and recover to current speed quickly when push the switch one more time.
 - **Mode 2** (down only)
It shifts down from current gear to one step lower speed when push the switch every time.
The kick down function is released in only 1st speed.
- ※ **The normal autoshift function continues after the kick down switch is released.**

③ Clutch cut off (C.C.O) mode

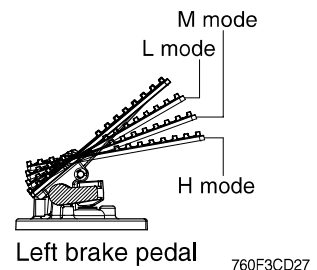
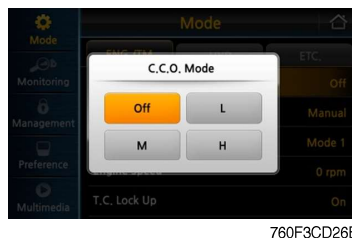

- Four modes are available for operator's preference and job condition.
 - OFF : The clutch cut off function is disable.
 - L (Low) : The clutch is disengaged early for short-distance and rapid loading.
 - M (Medium) : The clutch is disengaged normally for general digging and loading operation.
 - H (High) : The clutch cut off function is automatically adjusted depending on slope angle or machine load, And inching fuction becomes possible by using the brake pedal.
- The clutch cut off functions of the left brake pedal depend on the position of the left brake pedal and the setting of the clutch cut off mode.

Positions for clutch cut off function			
Clutch cut off mode	L	M	H
Left brake pedal	L, M	M	H

④ Shift mode



- Four modes are available for operator's preference and job condition.
 - Manual : Machine is operated by selected gear on lever.
 - AL (Auto Light) : Automatic shifting point is fast for long-distance transportation and fuel efficiency.
 - AN (Auto Normal) : Automatic shifting point is normal without automatic kick-down to 1st gear for general digging and loading operation.
 - AH (Auto Heavy) : Automatic shifting point is normal with automatic kick-down to 1st gear for more powerful operation.

⑤ Torque converter (T.C.) lock up mode (5-speed transmission)



- If you select ON, the lock-up clutch on the torque converter will automatically activate according to load.
- **Lock-up clutch function (option)**
To prevent power loss in the torque converter, the pump rotor and turbine rotor on the torque converter lock together through a direct lock-up clutch.

⑥ Work load

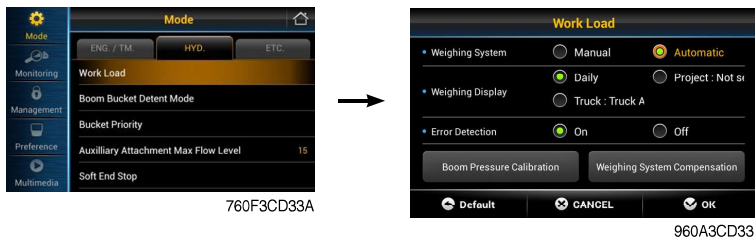

- Weighing system : Set the workload measurements.
- Weighing display : Set the display on main display screen.

Press Work mode switch on keypad shortly to shift weighing display.**

Weighing display - Daily	Weighing display – Project	Weighing display - Truck
	Work weight (Previous day)	
	Work weight (Today)	
	Current weight	
	Total weight accumulated in selected Project**.	
	Total weight accumulated in selected Truck**.	

** Refer to page 3-42 for details

- Error detection : Set error detection ON/OFF.
 - OFF : Errors are not displayed.
 - ON : ①, ② and ③ are displayed on main display screen.
 - ① The boom lift was performed too fast.
 - ② The bucket was not in the fully tilted back position while bucket was in the weigh range.
 - ③ The hydraulic temperature is low (below 40 °C).



- Boom pressure calibration : See the page 3-26 for details.
- Weighing system compensation
 - Calibration workload depending on work tool.
 - ※ **Only for the service person. Do not adjust arbitrary.**
 - ※ **Refer to page 3-42 for details.**

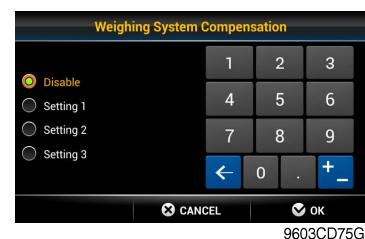

9603CD75G

※ **Weighing system**

- The weight indication in bucket is calculated by measuring boom position and boom pressure.

- Ⓐ The weight is '0.0 ton' when the boom is placed at below -15° .
- Ⓑ The weight is indicated when the boom is placed at the range $(-5^{\circ} \rightarrow 15^{\circ})$.
- Ⓒ The weight is calculated when the boom is placed at above -5° and boom is lowered below -15° after dumping operation.

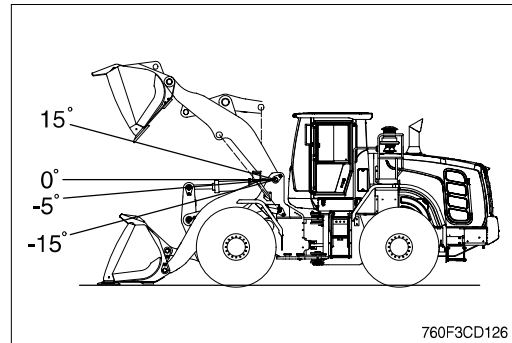

In order to recheck weight, go to the Ⓑ after changing boom position (below -15°).

- Dump operation : It is checked by bucket cylinder's stroke change (below 250 mm).

※ The temperature for the hydraulic oil must be raised to at least 40°C (104°F) before operation.

⑦ Boom/bucket detent mode

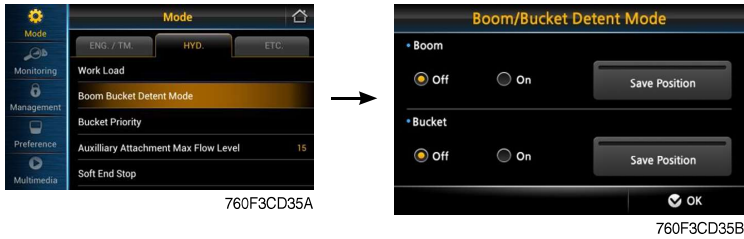

- OFF : Detent functions are not operated.
- ON : Boom or bucket detent functions are operated.
- Save position : Refer to page 4-22.

⑧ Bucket priority mode (option)



- Bucket priority function is to be more convenient for operator to load materials. Bucket-in (roll back) operation takes priority over the boom-up (raise) operation in case of using both operations at the same time.
- Set the bucket priority function ON/OFF.

⑨ Auxiliary attachment max flow level mode (option)



- If the machine is equipped with auxiliary attachment, auxiliary attachment flow can be easily adjusted and controlled.
- Set the oil flow level from 0 to 15 level by using +/- button.

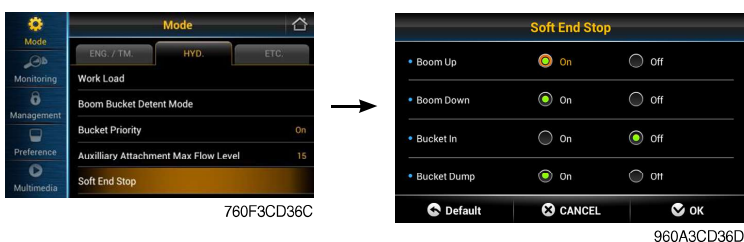

⑩ Soft end stop mode (option)

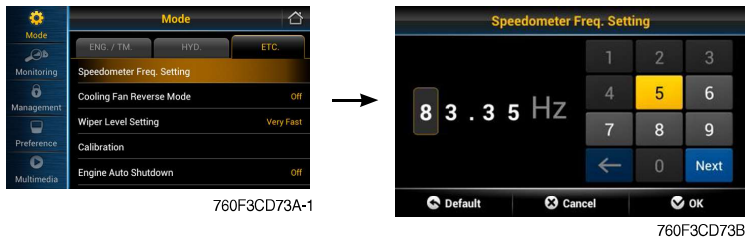

- This function gives shock free operation by reducing the speed of attachment near the end stroke.
- Set the soft end stop function ON/OFF.

⑪ Speedometer frequency setting mode



- Press speedometer setting bar (or ) for 3 seconds.
- ※ **Only for the service person. Do not adjust arbitrary.**
- ※ **Using button**
- To change the pulse value, press ◀ or ▶.
- To change the position, press .

⑫ Cooling fan reverse mode

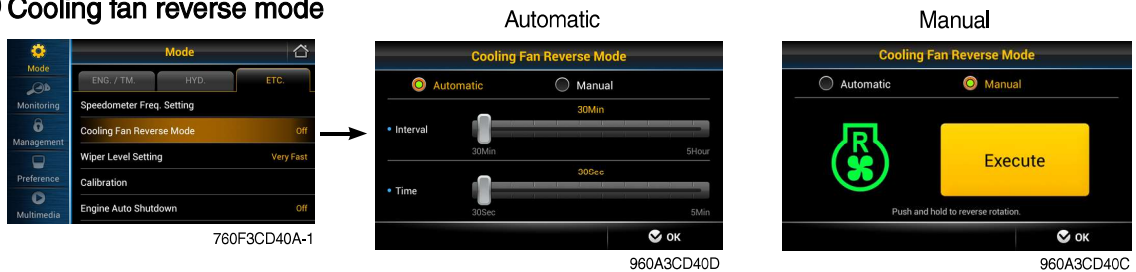

- **Manual** : Rotate the fan with reverse direction while pressing the button "Execute".
- **Automatic** : Rotate the fan with reverse direction by preset cycle.
 - Interval : 30 min ~ 5 hrs
 - Time : 30 sec ~ 5 min
- ※ **Default : Interval (60 min), time (120 sec)**

⑬ Wiper level setting (Intermittent mode)

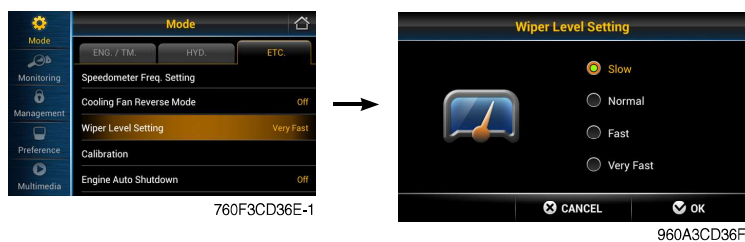

- Setting wiper speed in J position of multi function switch (slow, normal, fast and very fast)
- ※ Refer to the page 3-48.

14 Calibration

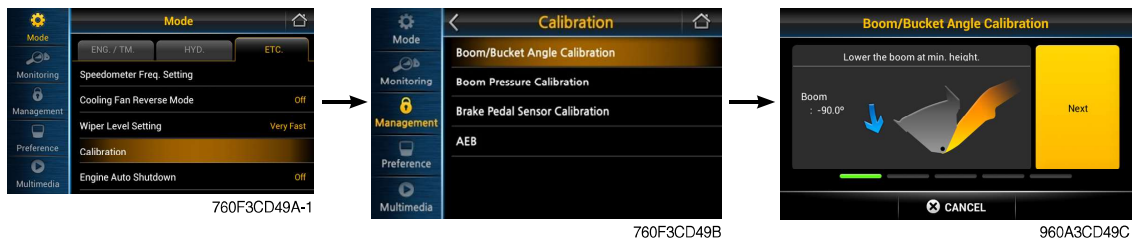

- You should turn OFF " Soft end stop " before start calibration.
- Press NEXT button after following the instruction at each step.
- If correction is right, NEXT button will be activated, then go to next stage.
- After following each step correctly, the message "Calibration completed" will be shown. Press OK button, then process be ended.

※ Using switch



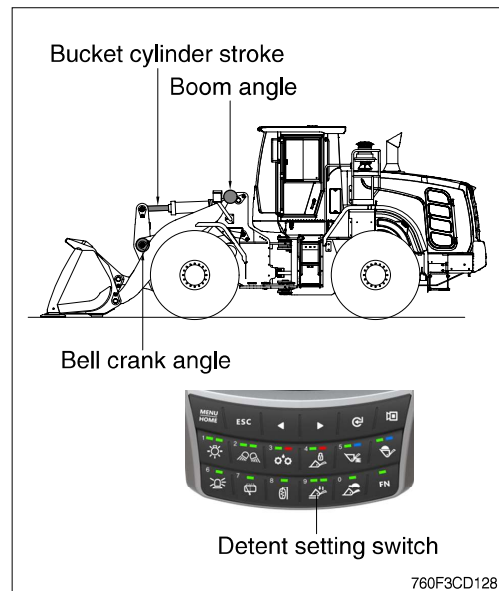

- Using  instead of NEXT, complete button.

· Boom / Bucket angle calibration

- MCU get sensing signal from boom angle and bell crank angle and calculate bucket cylinder stroke and boom link position angle from ground real time basis.
- Boom angle position and bucket cylinder stroke is set by detent setting switch on monitor.
- Individual setting position is done by lever (detent, release operation).
- Angle sensor calibration is basically carried out before delivery of the machine. When angle sensor is replaced or actual value is different compared to setting value, this function can be done.



- The calibration must be carried out as follows :

- ① Lower the boom at maximum low position and press NEXT button or  (bucket must be max tilting position).
- ② Raise boom at maximum high position and press NEXT button (or ).
- ③ Position boom at -5° and press NEXT button (or ).
- ④ Retract bucket cylinder length (to minimum position) at -5° boom position and press NEXT button (or ).
- ⑤ Extend bucket cylinder length (to maximum position) at -5° boom position and press NEXT button (or ).
- ⑥ In case above steps are carried normally, "Calibration is done" message is shown. Then angle sensor calibration is finished.

- ※ **Boom down / boom up / bucket position setting : Refer to page 4-22.**

· **Boom pressure calibration**

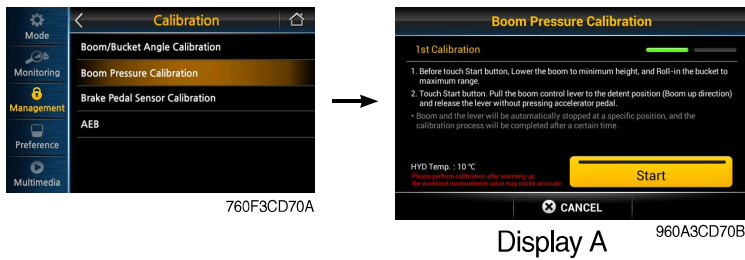

- Press START button after following the instruction.
- After a few minutes, "Calibration failed" or "Calibration completed" message will be shown. Press OK button then process be ended.

※ **Using button**

- Using instead of NEXT, complete button.

· **Boom pressure calibration**

- It is used when bucket weight is changed or measured weight is inaccurate.
- The calibration must be carried out as follows :
 - ① Increase hydraulic temperature (about 40~60°C).
 - ② Select "Boom-pressure".
 - ③ Roll-in the bucket at maximum range and lower the boom at minimum height.
 - ④ Press START button.
 - ⑤ Raise boom to maximum position. Boom up must be finished before stepping advance in "display A".
 - ⑥ If it show "Calibration success" message in a moment, press complete button (or).

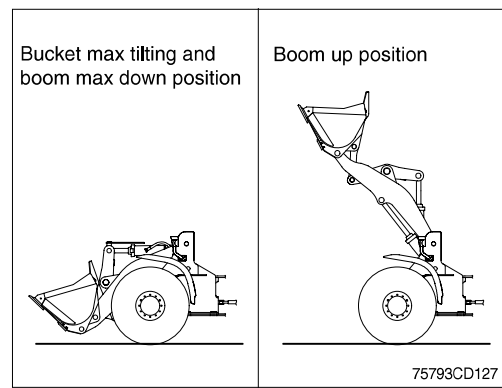

- ※ **Raise hydraulic temperature enough when checking work load / boom pressure sensor calibration (recommendation : about 40 ~ 60°C).**
- ※ **Check if pressure sensor or angle sensor is in normal condition for accurate work load algorism or pressure sensor calibration [pressure sensors at boom cylinder head area and rod area, boom angle sensor (CD-80), bell crank angle sensor (CD-81)].**
- ※ **Sensor error message during pressure sensor calibration : sensor need to be checked.**

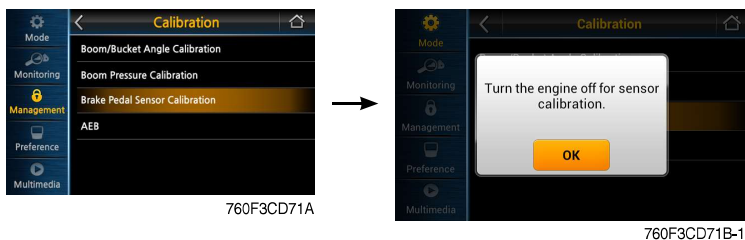

· **Brake pedal sensor calibration**

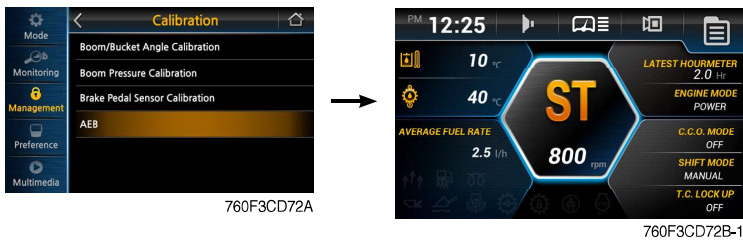

- Turn the engine OFF and turn the starting switch ON position.
- Press OK button, then calibration will be started.
- When display "IP " on main display, press slowly the brake pedal completely.
- Release the brake pedal when display "IP " on main display.
- For cancel, press MENU/HOME switch.
- ※ When the brake pedal or sensor is replaced, **brake pedal sensor calibration must be performed.**

AEB



- AEB mode controls the disk clearance of the transmission, automatically.
- To start AEB setting, press AEB bar (or ) for 3 seconds.
- If you press  or ESC, AEB setting will be canceled. Machine need to restart.
- If "OK" in actual gear window, press  to complete AEB setting.
- **Display during AEB mode**

Symbol	Meaning
ST	Start AEB
K1~K4, KV, KR	Calibrating clutch K1~K4, KV or KR respectively
OK*	Calibration for all clutches finished
Spanner and Kx*	Kx couldn't be calibrated, AEB finished
△E	Engine speed too low - Raise engine speed
▽E	Engine speed too high - Lower engine speed
△T	Transmission oil temperature too low - Heat up transmission
▽T	Transmission oil temperature too high - Cool down transmission
FO*	Output speed not zero
FN*	Shift lever not in neutral position
FP*	Parking brake not applied

* : Transmission stays in neutral, you have to restart the TCU (starting switch off/on).

15 Engine auto shutdown mode

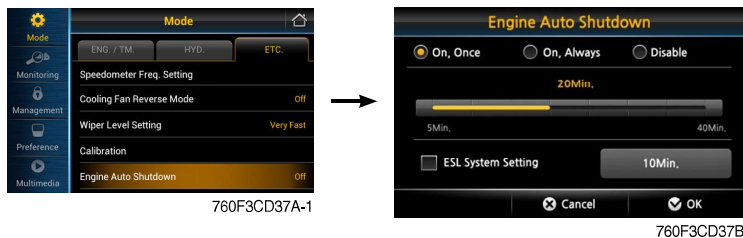

- The engine auto shutdown function can be activated or cancelled.
- If machine is idling for the setting time (2~40 minutes), then engine will be shutdown automatically.

(3) Monitoring

① Machine monitoring

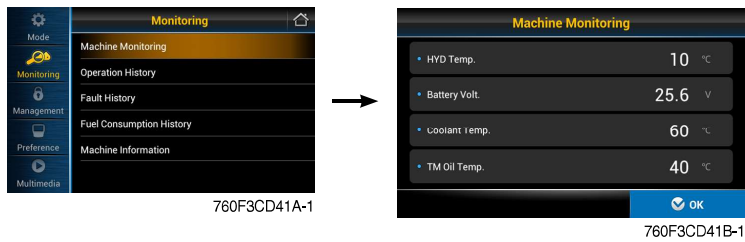

- Monitor the status of the machine.

② Operation history



- **Hour meter / ODO meter**
- **Total**
 - Total distance (this item cannot be initialized).
 - Total working hour can check on service meter. See page 3-59.
- **Latest**
 - Working hour/distance after reset.
 - If you select **Initialization**, working hour/distance start zero.
- To display the item in main display, select the item in main display. See the page 3-13.

③ Fault history

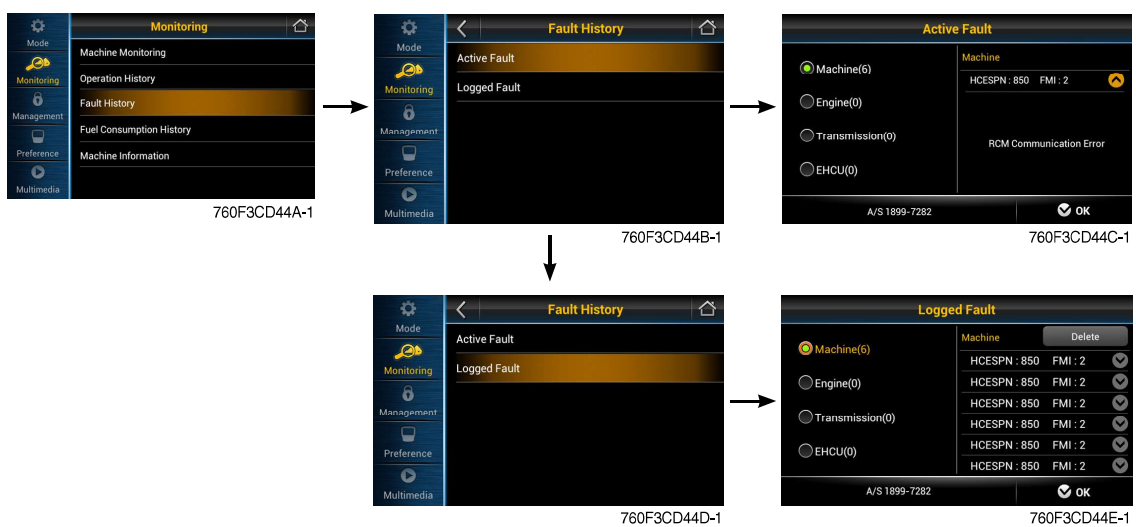

- Display the fault code of MCU/ECU/TCU/EHCU and delete logged fault.
- ※ Refer to service manual for HCESPN/FMI of engine and transmission.
- ※ EHCU : Electro Hydraulic Control Unit AAVM : All Around View Monitoring

④ Fuel consumption history

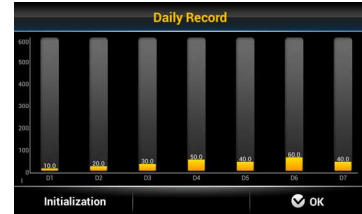
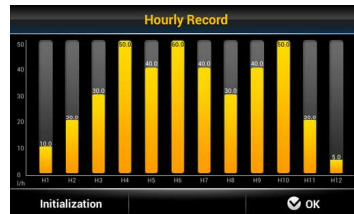
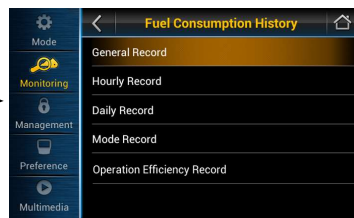
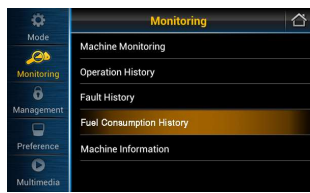

- Display the fuel consumption history.
 - General record (average fuel rate and a days fuel used)
 - Hourly record - Daily record - Mode record : P, P(smart), E mode
 - Operation efficiency record (Shuttle shift, Idle, Relief)

⑤ Machine information

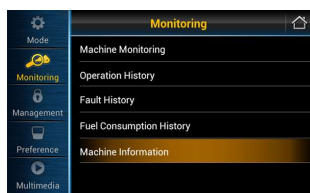

- Software versions of MCU, ECM, TCU, EHCU, RMCU, Cluster and monitor can be checked.

(4) Management

① Machine security

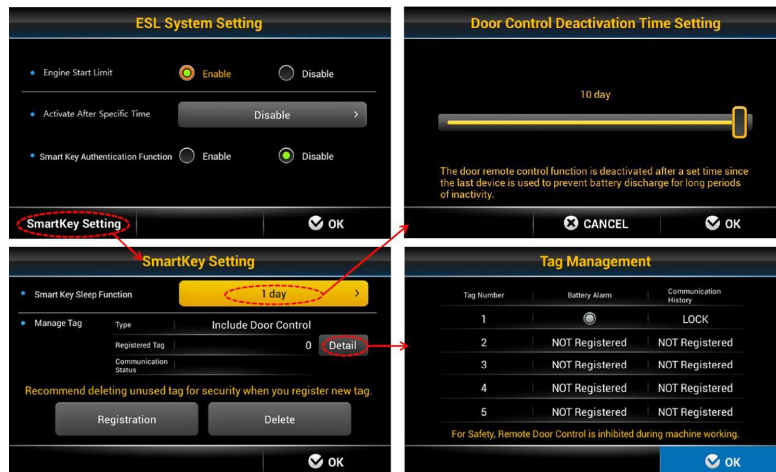
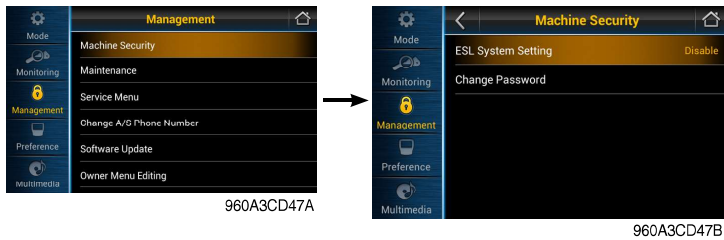

· ESL system setting

- ESL : Engine Starting Limit
- ESL mode is designed to be a theft deterrent or will prevent the unauthorized operation of the machine.
- If the ESL mode was selected ON, the password will be required when the start switch is turned ON.
- **Engine start limit**
 - . **Disable** : Not used ESL function
 - . **Enable** : The password is required whenever the operator start engine.
- **Activate after specific time**

The password is required when the operator start engine first. But the operator can restart the engine within the specific time without inputting the password.

The specific time can be set maximum 2 days.
- **Smart key authentication function (option)**
 - . **Enable** : Set the using or not of smart key. If you using smart key, ESL function always be activated.
 - . **Disable** : Register or delete user tag and display registered user tag. When delete user tag, all user tag will be deleted.

※ **Using smart key**

- **Verification success**

Green smart key icon is displayed on the main display screen.

- **Verification failure**

Red smart key icon and password input screen is displayed.



Verification success



Verification failure

※ **Remote door control system (option)**

- The machine operator can lock, unlock and open the cab door by means of the remote key tag, as long as he is within a range of 15 meters from the machine.
- Please note that the door cannot be closed using the Remote Key Tag.



- 1 Door lock
- 2 Door unlock
- 3 Door open (press and hold for 2 seconds)

⚠ Do not activate this function if there is person nearby the door and when machine work or travel.

· **Door control deactivation time setting**

- There is a limited period of a maximum of 10 days that can be set during which the ' Remote Door Functionality ' can be used if the machine has been parked or at a standstill.
- If the machine is parked or at a standstill for a period that exceeds the period in days set by the operator without any activity, then to prevent the machine batteries from draining, the ' Remote Door Functionality ' will be disabled.
- When this happens, the operator will be able to only use the machine Key to open the cab door, after which the ' Remote Door functionality ' can be enabled again during first start-up.
- During the first start-up after the machine was inactive for a period that exceeds the period in days set by the operator, the operator will be able to see the below pop-up on the monitor, by which the operator can then enable the ' Remote Door functionality ' again by clicking the ' Setting ' tab and confirming the settings thereafter.

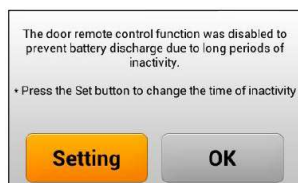

960A3CD47H



960A3CD47G

· **Tag management**

- Tag number
 - . Max 5 tags can be registered.
- Battery alarm
 - . Check tag's battery status. (normal or low)
- Communication history (check, lock, unlock, open)

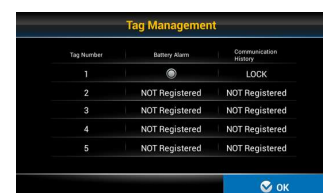

960A3CD47K

② Maintenance



- Replacement : The elapsed time will be reset to zero (0).
Change cycle : The change or replace cycle can be changed in the unit of 50 hours.
- Show the maintenance history below 10.
When history have more than 10, delete the old item.
- **Change or replace interval**

No	Item	Interval
1	Engine oil	800
2	Hydraulic oil	★1 2000 ★2 5000
3	Pilot line filter element	1000
4	Hydraulic oil return filter	1000
5	Engine oil filter	800
6	Fuel filter element	1000
7	Fuel pre-filter element	1000
8	Hydraulic tank air breather	1000
9	Air cleaner element	2000
10	Radiator coolant	2000
11	Transmission oil and filter	1000
12	Axle oil (front and rear)	1500
13	Aircon & heater outer filter	1000
14	Pressure filter element	1000
15	DEF/AdBlue® supply module filter	4500
16	DEF/AdBlue® Tank filter	2000
17	Aircon & heater inner filter	2000

★1 : Conventional hydraulic oil

★2 : Hyundai genuine long life hydraulic oil

③ Service menu



- **Sensor monitoring** : Display information of each sensors.
- **Speed limit setting** : 20~40 km/h (5 km/h intervals)
- **EHCU I/O information**
 - Real time monitoring (joystick stroke, EPPR current).

④ Change A/S phone number



- Check and change of contact information for customer service.

Software update

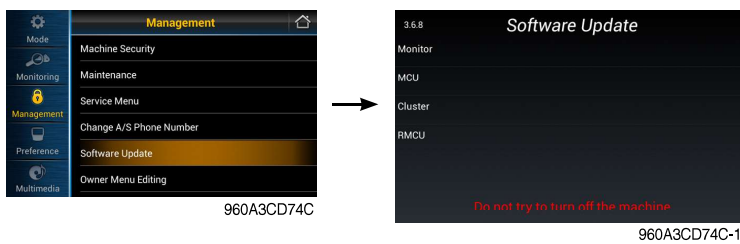

- Update file in USB memory.

⑤ Owner menu editing



- **Owner menu editing** : Owner can set the status of the function. (Enable / Disable)
- **Menu list** : In the menu, owner can set the list of the function to lock or unlock it.
- **Owner password change** (Default password : 11111)
 - Owner can manage and change the password.
 - Necessary to input the password to access the set of function.

(5) Preference

① Brightness setting

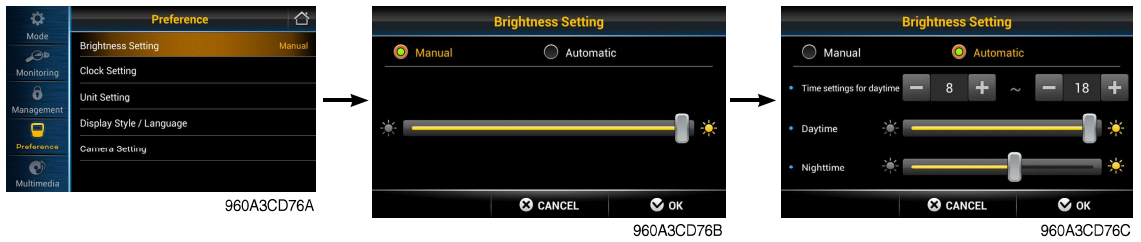

- **Manual**
 - Manual setting for LCD brightness.
- **Automatic**
 - Automatic control of LCD brightness as set level of day/night.
- **Setting day time**
 - Set the time for daylight.
 - If you set the time for daylight, the rest time will be night.

② Clock setting



- Set the time (hour, minute and AM or PM)

③ Unit setting

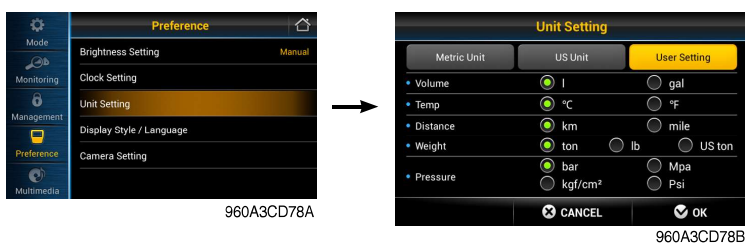

- Volume : l ↔ gal
- Temperature : °C ↔ °F
- Distance : km ↔ mile
- Weight : ton ↔ lb
- Pressure : bar ↔ Mpa ↔ kgf/m² ↔ psi

※ Using button

- Move to other item by

④ Display style/ Language

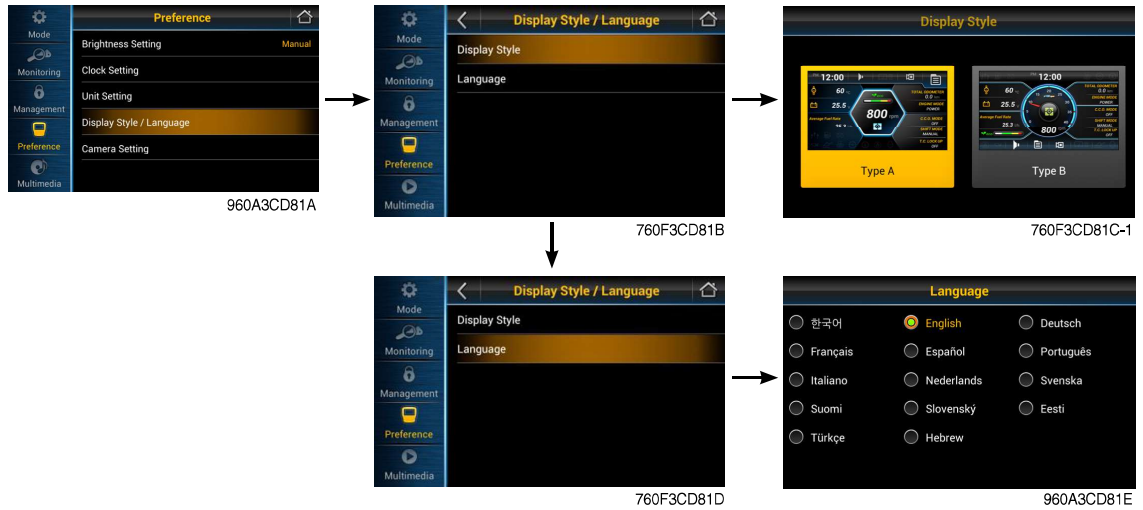

- Set the display type A or B.
- User can select preferable language and all display are changed the selected language.
- 14 multiple language available.

⑤ Camera setting

※ If the camera monitor is equipped, camera will showing on camera monitor only.

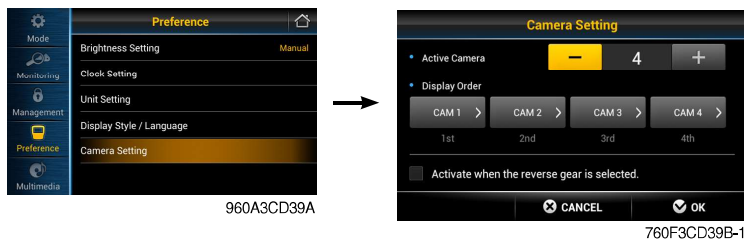

- **Active camera**
 - Four cameras can be installed on the machine.
 - **Display order**
 - Set the channel sequence of each camera.
 - **Active when the reverse gear is selected**
 - If transmission engages the reverse gear (R1~R3), the camera mode is displayed automatically in main display.
 - If the camera was not equipped, this menu is not useful.
 - If the camera monitor is equipped, camera will showing on camera monitor only. This menu is not useful. See the page 3-77.
 - In main display, if the is touched (or switch is pushed), the first ordered display camera will be viewed.
- ※ If AAVM is equipped, this menu will be changed to AAVM setting.

⑥ AAVM (Advance Around View Monitoring, option)

- ※ If the camera monitor is equipped, AAVM will showing on camera monitor only.
- The AAVM switches of the cluster consist of Camera, ESC and Buzzer stop.



- **Camera switch**
 - It will enter into the AAVM mode from the main display if the AAVM is installed.
 - If the camera monitor is equipped, AAVM will showing on camera monitor only. This menu is not useful. See the page 3-77.
 - While in the AAVM mode, select the ESC switch to return to the main display.

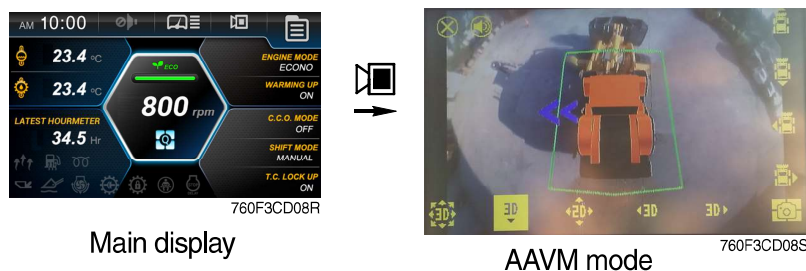

- **Buzzer stop switch**
 - In AAVM mode, it detects surrounding pedestrians or objects and the warning buzzer sounds.
 - User can turn OFF the warning sound by pressing buzzer stop switch.



290F3CD246

- When the worker or pedestrian go near the danger area line (green, radius 3 m), an external danger area of equipping on the main display, the warning buzzer sounds and it displays the green rectangular box for the recognition of the worker and pedestrian. At this time, the operator should stop work immediately, and stop the buzzer by pressing the buzzer stop switch. And then, please work after you check whether the danger factors are solved.



290F3CD247

- When the worker or pedestrian go inside of the danger area line (red, radius 3 m), an internal danger area of equipping on the main display, the warning buzzer sounds and it displays the red rectangular box for the recognition of the worker and pedestrian. At this time, the operator should stop work immediately, and stop the buzzer by pressing the buzzer stop switch. And then, please work after you check whether the danger factors are solved.

(6) Multimedia

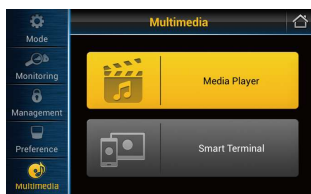

960A3CD83A



760F3CD83A

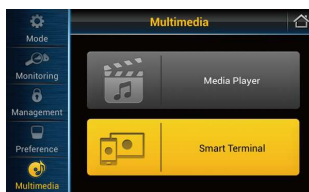

960A3CD83C

- Media player

- Play video files in USB (mp4, mkv, avi, 3gp, divx, f4v, flv, mpeg, mov, vob, wmv, webm, xvid).
- Play audio files in USB (mp3, mp4, ogg, wma, wav, flac, aac).

- Smart terminal

- The menu features a smartphone and operates the miracast.

▲ Operation of screen mirroring can be dangerous while driving.

Driver is responsible for accident or other damages. Operate the screen mirroring while stopping for safety.

3) PILOT LAMPS

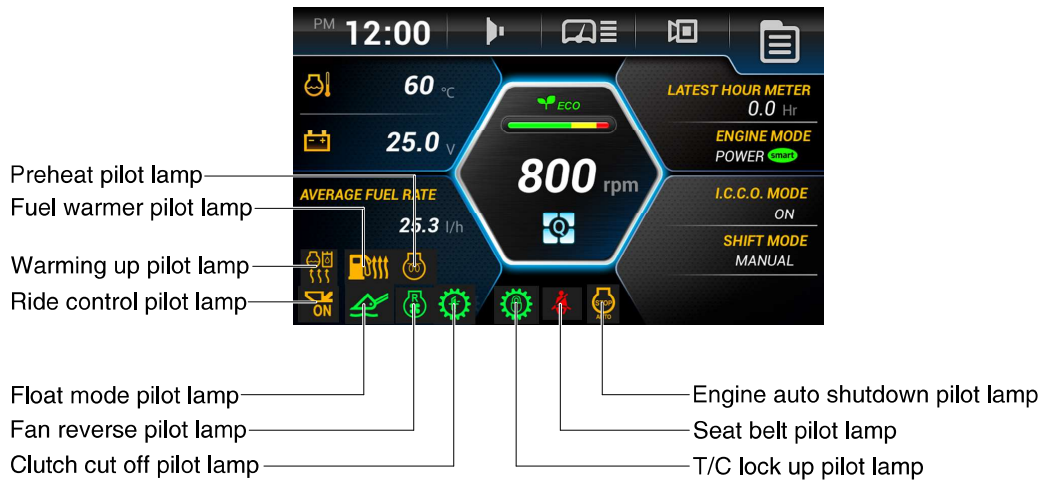

960A3CD90

(1) Warming up pilot lamp



- ① This lamp lights ON when the coolant temperature is below 30°C (86°F).
- ② The automatic warming up is cancelled when the engine coolant temperature is above 30°C, or when 10 minutes have passed since starting the engine.

(2) Seat belt pilot lamp



- ① This lamp lights ON for the first five seconds after starting the engine.

(3) Preheat pilot lamp



- ① This lamp lights ON when start switch is turned clockwise to the ON position. Light will turn off after approximately 5~45 seconds, depending on engine temperature, indicating that preheating is completed.
- ② When the lamp goes out the operator should start cranking the engine.

※ Refer to page 4-5.

(4) Engine auto shutdown pilot lamp



- ① This lamp lights ON when the engine auto shutdown function is activated.
- ※ Refer to page 3-27.

(5) Clutch cut off pilot lamp

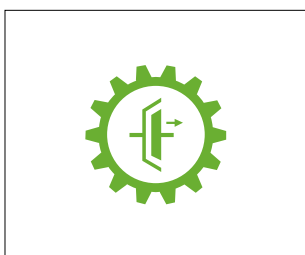

- ① This lamp lights ON when clutch cut off mode is set L, M, H.
- ※ Refer to page 3-20.

(6) Float mode pilot lamp

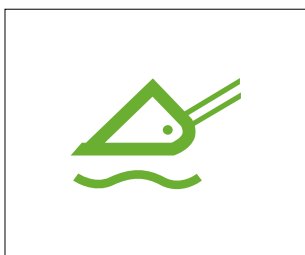

- ① This lamp lights ON when the boom float is activated.
- ※ Refer to page 4-9.

(7) Ride control pilot lamp (option)



- ① **Auto ride control**
This lamp lights ON when the automatic ride control function is activated (**ON**, **Conditional speed** setting).
- ※ Refer to page 3-41.



- ② **Manual ride control**
This lamp lights ON when the manual ride control function is activated (**ON**, **Always** setting).
- ※ Refer to page 3-41.

(8) Fan reverse pilot lamp



- ① This lamp lights ON when the cooling fan reverse mode is activated
- ※ Refer to page 3-24.

(9) Torque converter lock up pilot lamp (option)



- ① This lamp lights ON when the torque converter lock up function is operating.
- ※ Refer to page 3-21.

(10) Fuel warmer pilot lamp

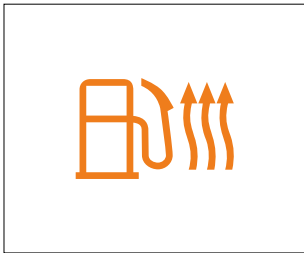

- ① This lamp is turned ON when the coolant temperature is below 10°C (50°F) or the hydraulic oil temperature 20°C (68°F).
- ② The automatic fuel warming is cancelled when the engine coolant temperature is above 60°C and the hydraulic oil temperature is above 45°C since the start switch was ON position.

3) SWITCHES

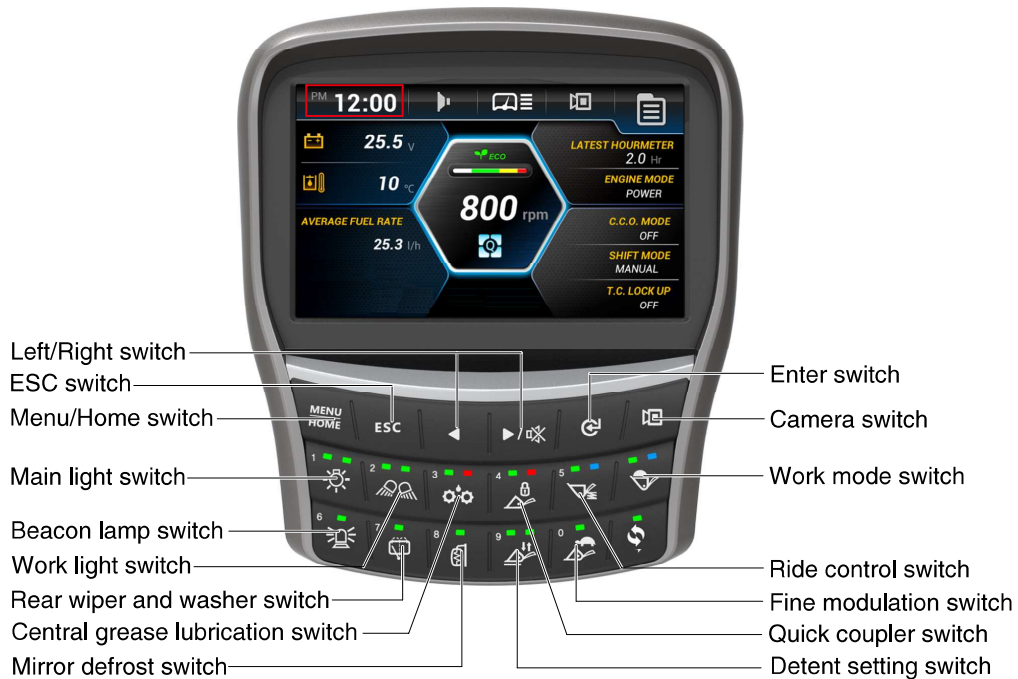

760F3CD95-1

※ If you push left or right switch (◀ ▶) on main display, show the select box on current time. Move to next item in order by using left / right button.

(① Time → ② Buzzer → ③ Wiper → ④ Camera → ⑤ Menu → ⑥ Machine monitoring → ⑦ Fuel rate → ⑧ Engine mode/Operation history → ⑨ Transmission mode → ⑩ Quick menu)

※ Move to selected setting screen by using enter switch (⏎).

※ When keypad is not pressed for 3 seconds, convert screen to main display.

※ If you push left and right switch (◀ ▶) at the same time, move language settings.

(1) Menu / Home switch



① Main display to main menu, main menu to main display.

(2) ESC switch



① For other menu, this is used for cancellation (move to previous menu).

② AEB cancel or finish button in AEB.

(3) Left / Right move switch

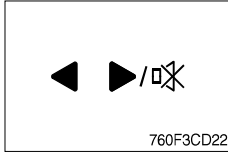

- ① Move in menu (left, up / right, down).
- ② Decrease / Increase input value.
- ③ Stop buzzer sound when sound is on.

(4) Enter switch



- ① Select menu (enter).

(5) Camera switch

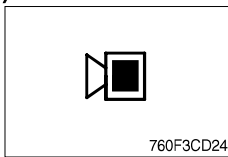

- ① Enter camera or AAVM mode in main display.
- ② If the camera monitor is equipped, camera or AAVM will showing on camera monitor only. This switch is not useful. See the page 3-77.

(6) Main light switch

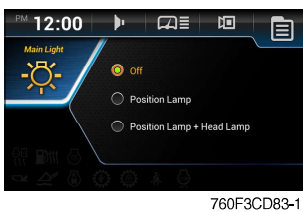

- ① This switch use to operates the clearance lamp and head light.
 - **Position lamp** : Clearance lamp and cluster illumination lamp come ON. The green pilot lamp is turned ON.
 - **Head lamp + Position lamp** : Clearance lamp, cluster illumination lamp and head light come ON. The green pilot lamp is turned ON.

(7) Work lamp switch

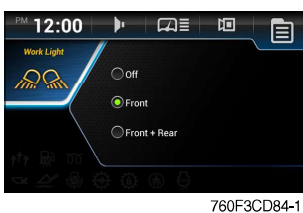

- ① This switch use to operates the front and rear work lamps.
 - **Front** : Front work lamp located on the cab comes ON. The green pilot lamp is turned ON.
 - **Front + Rear** : Front work lamp located on the cab and rear work lamp located on the cowl come ON. The green pilot lamp is turned ON.

(8) Central grease lubrication switch (option)

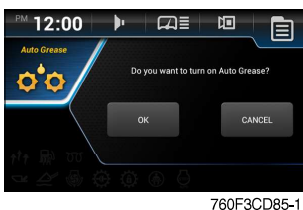

- ① This switch is used to operate the central grease lubrication system.
 - ② The central grease lubrication system is operated for set period. The green pilot lamp is turned ON.
- ※ **When malfunction occur in grease lubrication system, the red pilot lamp is turned ON.**
- ※ **Refer to page 8-1.**

(9) Quick coupler switch (option)

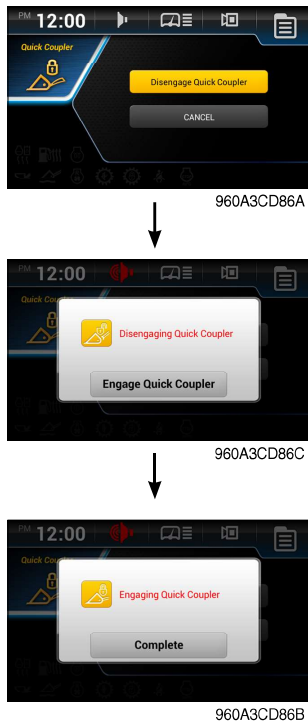

① Disengage quick coupler

- The quick coupler pins move in the disengaged position and buzzer sounds.
- The red pilot lamp is turned ON.

⚠ **Always check that the attachment is properly secured to the attachment quick coupler by pressing the front part of the attachment against the ground.**

⚠ **Never use an attachment before you have checked its mounting.**

② Engage quick coupler

- The quick coupler pins move in the engaged position and buzzer sounds.
- The green pilot lamp is turned ON.

※ **Check for engagement as followings.**

- Put down pressure on the attachment.
- Back up the machine and make sure that there is no movement between the quick coupler and attachment.

(10) Ride control switch (option)



① Forward / Backward 1~15 km/h

- The ride control automatically turns on when the travel speed exceeds a preset speed. (forward / backward 1~15 km/h)
- The blue pilot lamp is turned ON.

② ON, Always

- Select **ON, Always** in order to turn on the system for ride control regardless speed. The ride control will smooth the ride of the machine during travel.
- The green pilot lamp is turned ON.

③ ON/OFF

Select **ON/OFF** in order to turn on/off the system for the ride control.

(11) Work mode switch

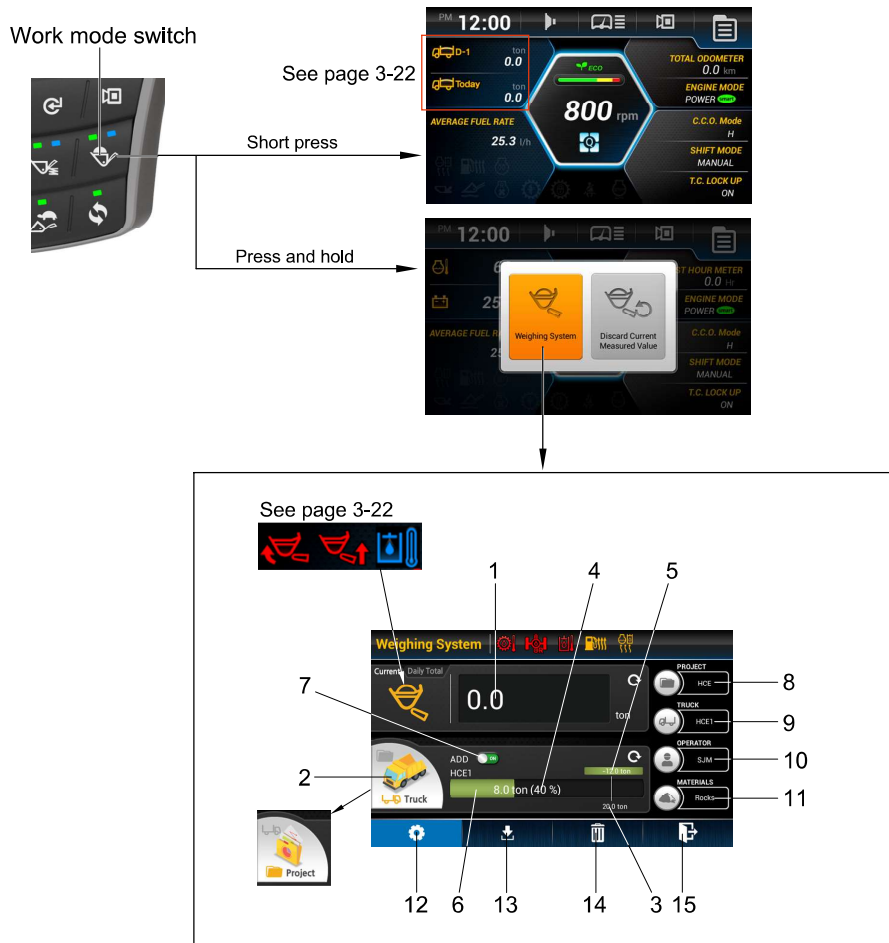

960A3CD115

- | | | | |
|---|---|----|---|
| 1 | Current weight in the bucket /
Daily total weight | 7 | Select button for mode
(Standby mode / Weigh mode) |
| 2 | Select button (Click gray icon)
for status (Project status / Truck status) | 8 | Project name |
| 3 | Target weight | 9 | Truck name |
| 4 | Loaded weight | 10 | Operator |
| 5 | Remaining weight to complete job /
Over weight to complete job | 11 | Materials |
| 6 | Progress bar / Total weight | 12 | Go to Work load setting menu |
| | | 13 | Save Work log to USB |
| | | 14 | Delete Work log |
| | | 15 | Go to Main menu |

① Current weight in bucket/ Daily total weight

- This window displays the measured current weight information of the current bucket. Daily Total information accumulated up to today is displayed.
- Current / Daily Total changes the display status by clicking the tab
- The unit of weight depends on the monitor settings.

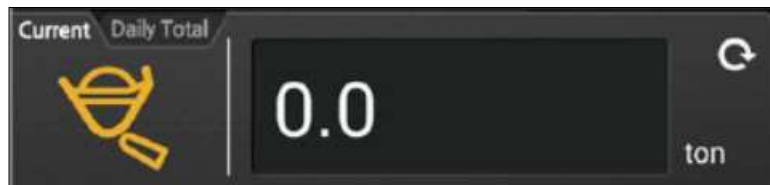

940A3CD10

② Select Button(Click gray icon) for status (Project status/Truck status)

- This button can select the cumulative weight of the project or the cumulative weight of the truck
- If you click on the gray icon, the icon will be changed Project →Truck or Truck →Project.



940A3CD11



940A3CD12

③ Target Weight

- It displays the set target weight value of Project or Truck. It can be set in the pop-up window.

④ Loaded weight (Progress bar or Total weight)

- It displays the set target weight value of Project or Truck. It can be set in the pop-up window.
- In the case of Truck status, percentage symbol (%) of the target value is displayed after the accumulated value. (Loaded weight / Target weight * 100)
- In the case of Truck status, it is displayed in the form of a Progress bar. The size of the entire bar is set to 120% of the target value, and the color of the bar is green when the target value is below and red when the target value is exceeded.

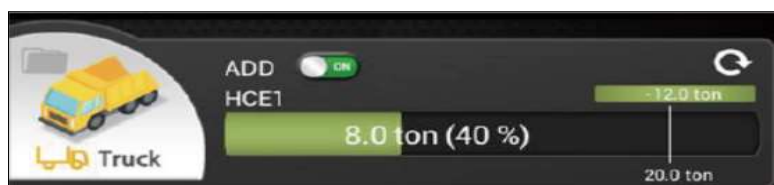

940A3CD13

- In the case of project status, it is displayed as 'Loaded weight / Target weight'.
In the case of project status, if the accumulated value exceeds the target value, the text of the accumulated value is displayed in red.



940A3CD14

⑤ Remaining weight to complete job (or Over weight to complete job)

- This setting is displayed only when Truck status is selected.
- Displays the amount of work remaining from the current accumulated value to the target value. (Current cumulative value - Truck target value)

⑥ Progress bar/ Total weight

- If the current cumulative value is below the target, it is marked with negative number and green, and if it exceeds the target, it is marked with positive number and red.

⑦ Select button for mode (Standby mode / Weigh mode)

- In the Standby mode, the measured current weight value is not added to the accumulated value.
- In Weigh mode, the measured current weight value is added to the accumulated value.
Set to Weigh mode when 'ON' is displayed and Standby mode when 'OFF' is displayed



940A3CD15

⑧ Project Name

- If you touch the right Project icon and text on the Weighing System main screen, the following pop-up is created.



940A3CD16

- Select the 'None' Project in advance as the initial default value. The project cannot be deleted.
- Touch one of the input projects and press 'Select' to select the project. After multi-selection, press 'Select' to display a warning message to select only one
- Touch one of the input projects and press 'Select' to select the project. (Multi selectable)
- Touch one of the input projects and press 'Delete' to delete the project. (Multi selectable)
- When you touch '+ Add', a qwerty keyboard appears so you can enter a new Project Name.



940A3CD17

- If you touch the red circle, a window for entering the target value appears. After entering the target value, touch 'Save' to complete the setting.
- The unit of weight follows the setting of the monitor.
- When the number of items is exceeded, a 'You cannot add more.' toast message is generated.
- When adding an item with the same name, a 'You cannot add same item.' toast message is generated



940A3CD18

⑨ Truck Name

- If you touch the right truck icon and text on the Weighing System main screen, the following pop-up is created. (The current Project Name and Truck Name are displayed at the top)

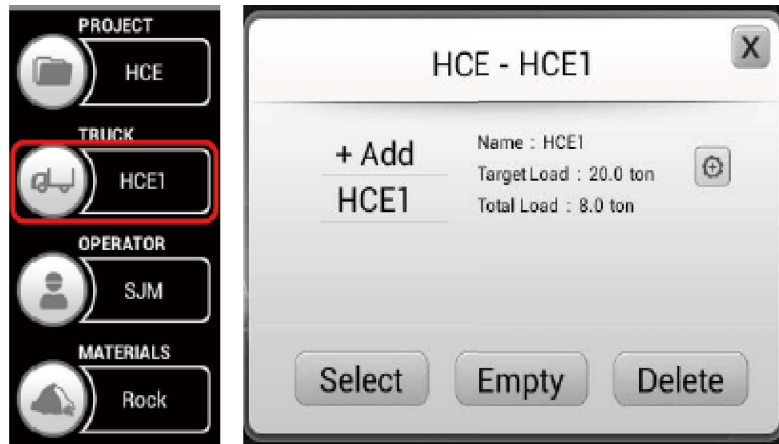

940A3CD19

- Initially, Total A, Total B, and Total C are created in advance in the Truck List of the 'None' project. 'Total A' is selected as the default value. Trucks cannot be added or deleted in the 'None Project'. Display warning message that adding/removing is impossible.
- Touch one of the entered trucks and press 'Select' to select the truck. After multi-selection, press 'Select' to display a warning message to select only one.
- Touch the entered truck and press 'Delete' to delete the truck (multi selectable)
- Touch the entered truck and press 'Empty' to delete all information in the truck.(multi selectable)
- Touching '+ Add' brings up a qwerty keyboard to enter a new Truck Name.
- If you touch the red circle, a window for entering the target value appears. After entering the target value, touch 'Save' to complete the setting.
- The unit of weight follows the setting of the monitor.
- When the number of items is exceeded, a 'You cannot add more.' toast message is generated.
- When adding an item with the same name, a 'You cannot add same item.' toast message is generated.



940A3CD20

⑩ Operator

- The pop-up below is created by touching the right operator icon and text on the Weighing System main screen.
- Touch one of the input operators and press 'Select' to select the operator.
- Touch the entered operator and press 'Delete' to delete the operator. (multi-selectable)
- When you touch '+ Add', a qwerty keyboard appears to enter a new operator.
- When the number of items is exceeded, a 'You cannot add more.' toast message is generated.



940A3CD21

⑪ Materials

- The pop-up below is created by touching the right operator icon and text on the Weighing System main screen.
- Touch one of the input materials and press 'Select' to select the material.
- Touch the input material and press 'Delete' to delete the material. (multi selectable)
- Touching '+ Add' brings up a qwerty keyboard to enter a new material.
- The related contents are saved in the monitor, and the material is limited to 20.
- Send, Gravel, Aggregate, and Rocks are saved in advance as default material values.
- When the number of items is exceeded, a 'You cannot add more.' toast message is generated.
- When adding an item with the same name, a 'You cannot add same item.' toast message is generated



940A3CD22

⑫ Go to Work load setting menu

- Move to the Work load setting menu below.



940A3CD23

⑬ Save Work log to USB

- Touch the red marked part on the monitor to execute the USB storage function. If the USB is not plugged in, a pop-up will notify you.

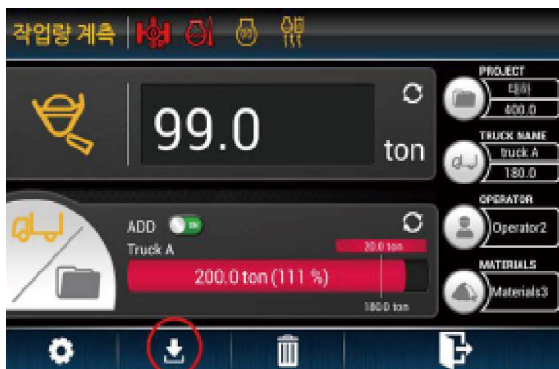

940A3CD24



940A3CD25

- When the USB is plugged in, the pop-up notifies that the USB workload measurement record data is automatically saved.



940A3CD26

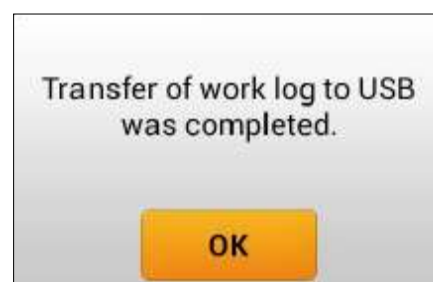

940A3CD27

⑭ Delete Work log

- Clicking the trash can icon deletes all stored workload measurement data.

⑮ Go to Main menu

- Click the exit icon to move to the monitor main menu screen.

(12) Rear wiper and washer switch

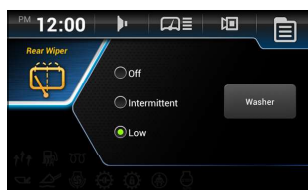

760F3CD89-1

- ① This switch use to operates the rear wiper and washer.
When pressing the switch, the mode is changed sequence base.
(OFF → intermittent → Low → OFF)
 - **Intermittent** : The rear wiper operates intermittently.
 - **Low** : The rear wiper is operated lower speed.
 - **Washer** : The washer liquid is sprayed while long pressing the button.
- ② The green pilot lamp is turned ON.

(13) Beacon lamp switch (option)

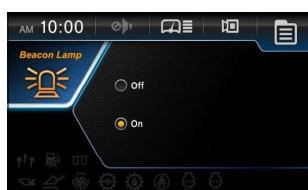

760F3CD88

- ① This switch turns ON the rotary light on the cab.
- ② The green pilot lamp is turned ON.

(14) Mirror defrost switch (option)

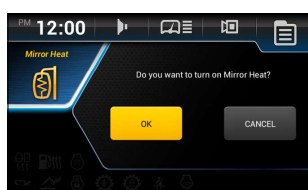

960A3CD65A

- ① **ON**
 - In condition of ON, it operates for 15 minutes. After 15 minutes, the defrost function stops automatically.
 - The green pilot lamp is turned ON.
- ② **OFF**
 - Stops defrost function.

(15) Detent setting switch



760F3CD66

- ① **Boom and bucket**
 - Set the boom and bucket detent function ON/OFF.
 - ② **Save position**
 - Set the boom kickout and bucket leveler.
 - Refer to page 4-22.
- ※ **The green pilot lamps are turned ON.**

(16) Fine modulation switch

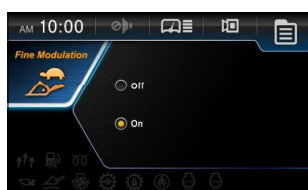

760F3CD67

- ① **ON**
 - Remote control lever provide the operator with precise control of the work equipment (bucket and boom cylinders can be controlled precisely).
 - The green pilot lamp is turned ON.
- ② **OFF**
 - Turn off the function.

4. SWITCHES

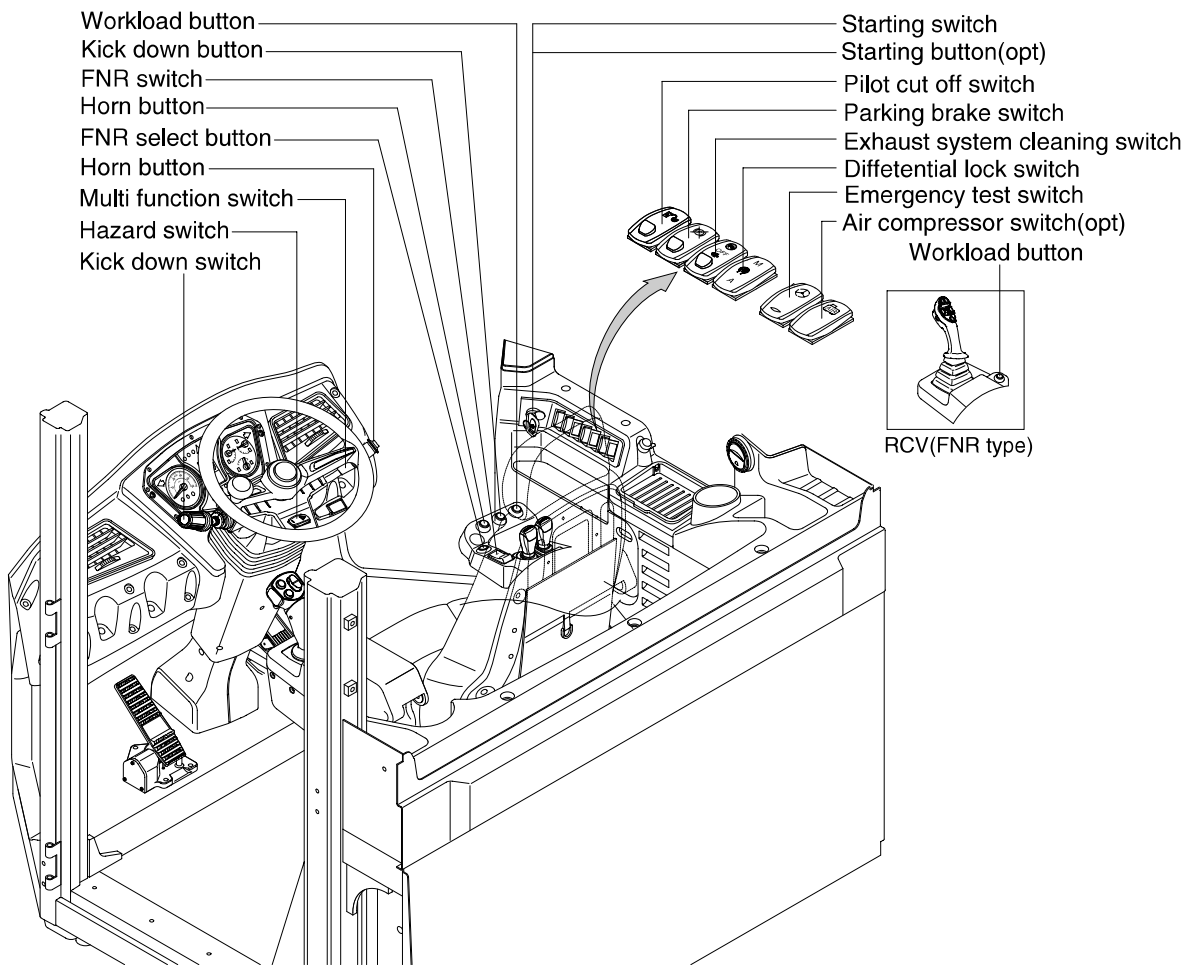

960A3CD29A

1) STARTING SWITCH & STARTING BUTTON (OPT)

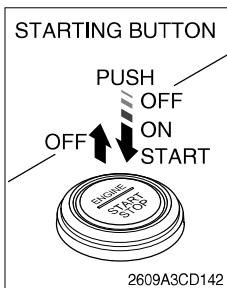
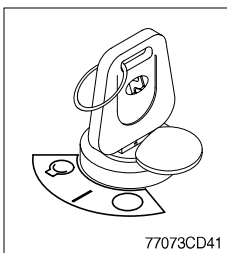

Starting button with smart key tag (opt)

(1) There are three positions, OFF, ON and START.

- ○ (OFF) : None of electrical circuits activate.
- | (ON) : All the systems of machine operate.
- Ⓞ (START) : Use when starting the engine.

Release key immediately after starting.

※ If you turn ON the starting switch in cold weather, the fuel warmer is automatically operated to heat the fuel by sensing the coolant temperature. Start the engine in 1~2 minutes after turning ON the starting switch. More time may take according to ambient temperature.

※ Key must be in the ON position with engine running maintain electrical and hydraulic function and prevent serious machine damage.

2) PILOT CUT OFF SWITCH



- (1) When the switch is pressed to OFF position, the hydraulic pilot line will be cut off, so the work equipment will not operate.
 - (2) Press the ON position in order to unlock the hydraulic pilot line.
- ※ **This switch can be set to ON or OFF position only when the safety button is pulled to the unlock position.**

3) PARKING BRAKE SWITCH

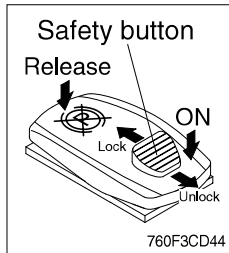

- (1) When the switch is pressed to ON position, the parking brake will start to operate and the cluster warning lamp will come ON.
 - (2) Press the release position in order to disengage the parking brake.
- ※ **When operating the gear selector lever, be sure to release the parking brake. If the machine is operated with the parking brake engaged, the brake will overheat and may cause the brake system to go out of order.**
- ※ **This switch can be set to ON or Release position only when the safety button is pulled to the unlock position.**

※ **If you turn ON the starting switch with the parking brake disengaged (release position), the parking brake will be engaged.**

To release the parking brake, press the parking brake switch to ON and Release position.

4) EMERGENCY TEST SWITCH (option)

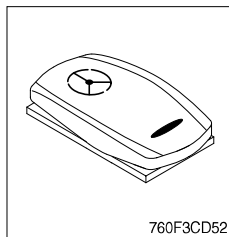

- (1) The emergency steering system can be manually tested. Push the switch in order to determine if the emergency steering and the emergency steering lamp are functional.
- (2) When the switch is pressed, the emergency steering pump motor will run. The emergency steering lamp will light. If the emergency steering lamp does not light, do not operate the machine.

5) DIFFERENTIAL LOCK SWITCH (option)

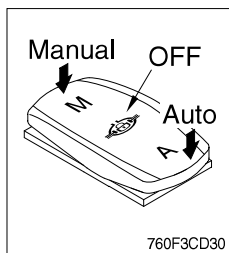

- (1) This switch is used to apply differential lock. The differential lock gives equal power to both front wheels and is used in conditions when traction is poor.
- (2) **Manual mode**
Press the **M** of the switch for the manual mode of the differential lock function. You press the switch, the differential lock will engage immediately and differential lock pilot lamp lights ON (buzzer sounds). Manual mode is temporarily engaged as long as the operator pushes the switch. When the switch is released, differential lock function is disengaged and the switch returns to OFF position.

(3) Auto mode

Press the **A** of the switch for auto mode of the differential lock function. If you press the switch, the axle differential lock will automatically engage when the differential function is used.

- ※ **While the axle differential lock function is operating, the differential lock pilot lamp lights ON.**
- ※ **Refer to page 3-12 and 3-52 (diff lock foot switch).**

6) EXHAUST SYSTEM CLEANING SWITCH

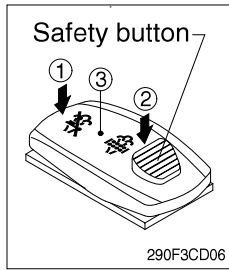

(1) This switch is used to select the exhaust system cleaning.

(2) Inhibit position (①)

- ① The inhibit position disallows any automatic or manual exhaust system cleaning.
- ② This may be used by operator to prevent exhaust system cleaning when the machine is operating in a hazardous environment is concerned about high temperature.
- ③ It is strongly recommended that this position is only activated when high temperatures may cause a hazardous condition.

(3) Auto position (③)

This position will initiate a automatic exhaust system cleaning.

(4) Manual position (②)

- ① This position will only initiate a manual exhaust system cleaning when the machine is in non-mission condition, engine must run at low idle speed and exhaust system levels are high enough to allow cleaning.
 - ② HEST lamp will be illuminated during the entire exhaust system cleaning.
- ※ Refer to the page 3-9 for details.
- ※ This switch can be move to the manual position (②) only when the safety button is pulled to backward.
- ※ Also, this switch return to the auto position when released the manual position (②).

7) HORN BUTTON

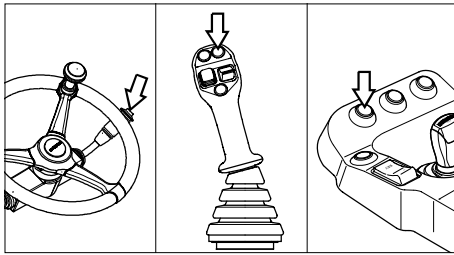

(1) If you press the button, the horn will sound.

8) CAB LAMP SWITCH

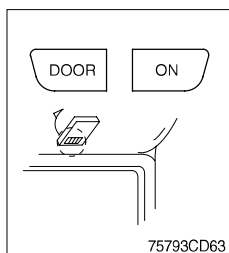

(1) This switch turns ON the cab room lamp.

① DOOR

The lamp comes ON when the door is opened.
When the door is closed the lamp is OFF.

② ON

This switch is used to turn the lamp ON or OFF.

9) KICK DOWN SWITCH

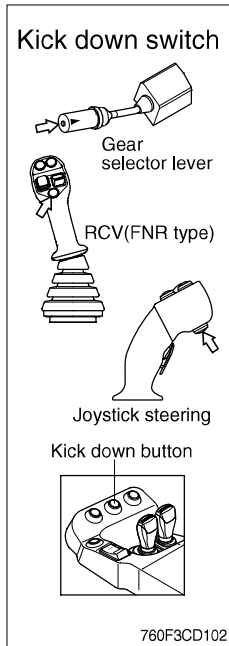

(1) Manual mode

It is effective 2nd speed to 1st speed only and recover to 2nd speed quickly when push the switch one more time.

(2) Automatic mode

① Mode 1 (down/up)

It shifts down quickly from current gear to one step lower speed by pushing the switch and recover to current speed quickly when push the switch one more time.

② Mode 2 (down)

It shifts down from current gear to one step lower speed when push the switch every time.

The kick down function is released in only 1st speed.

※ Refer to page 3-20 for the kick down mode.

※ The normal autoshift function continues after the kick down switch is released.

10) FNR SELECT BUTTON AND SWITCH

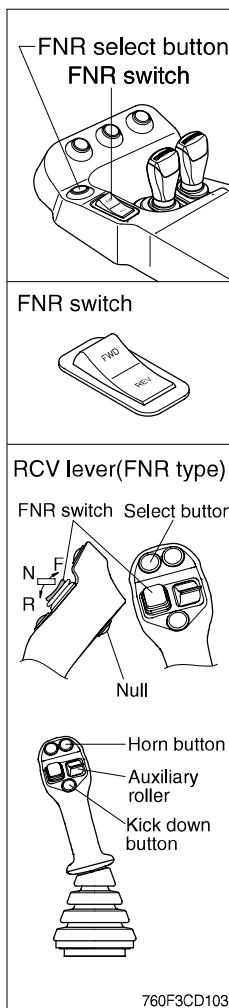

(1) These button and switch are used for forward and backward drive.

※ Gear range can be selected by gear selector lever.

(2) FNR select button

① If the select button is pressed, the indication lamp on the cluster will be ON and this FNR switch will start to operate.

※ When the engine is running, the machine is on standstill (0 speed), parking brake is released, gear selector lever is in the neutral position, you can use this function after pressing the select button.

(3) FNR switch

- F : Forward drive
- N : Neutral
- R : Reverse drive

① If the upper side (F, FWD) of this switch is pushed, the machine moves forward.

② If the down side (R, REV) of this switch is pushed, the machine moves backward.

③ This function is automatically released when the engine is stopped, parking brake is ON or gear selector lever is out of neutral.

(4) Auxiliary roller : If the machine is equipped with auxiliary hydraulics, this roller is used for the attachments.

11) WORKLOAD BUTTON

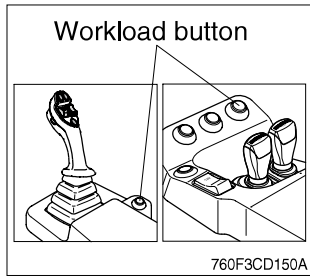

- (1) This button is used to calculate the weight manually.
If the button is not pushed, the weight of the weighing system is not calculated.
 - (2) This button is pushed for one second more, calculated weight will be accumulated.
- ※ Refer to the page 3-22, weighing system.

12) HAZARD SWITCH

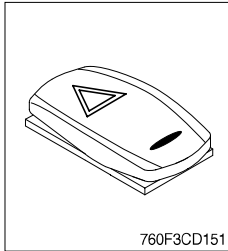

- (1) Use for parking or loading the machine.
 - (2) Both turn signal lights will flash simultaneously.
- ※ If the switch is left ON for a long time, the battery may be discharged.

13) MULTI FUNCTION SWITCH

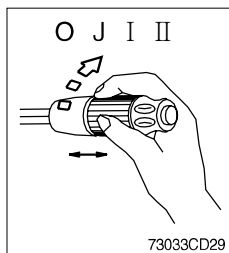

(1) Front wiper and washer switch

- ① When the switch is in J position, the wiper moves intermittently.
※ Refer to the page 3-24 (Wiper level setting).
 - ② When placed in I or II position, the wiper moves continuously.
 - ③ If you push the grip of the lever, washer liquid will be sprayed and the wiper will be activated 2-3 times.
- ※ Check the quantity of washer liquid in the tank. If the level of the washer liquid is LOW, add the washer liquid (in cold, winter days) or water. The capacity of the tank is 1 liter.
- ※ If the wiper does not operate with the switch in ON (J, I, II) position, turn the switch OFF (O) immediately and check the cause. If the switch remains ON, motor failure can result.

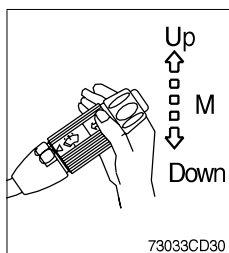

(2) Dimmer switch

- ① This switch is used to turn the head lights direction.
- ② Switch positions
 - Up : To flash for passing
 - Middle : Head lights low beam ON
 - Down : Head lights high beam ON
- ③ If you release the switch when it's in up position, the switch will return to middle.

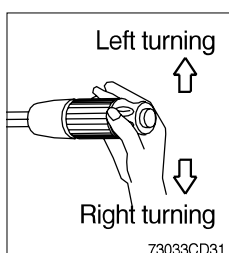

(3) Turning switch

- ① This switch is used to warn or signal the turning direction of the machine to other vehicles or equipment.
- ② Push the lever up for turning left, pull the lever down for turning right.

5. CONTROL DEVICE

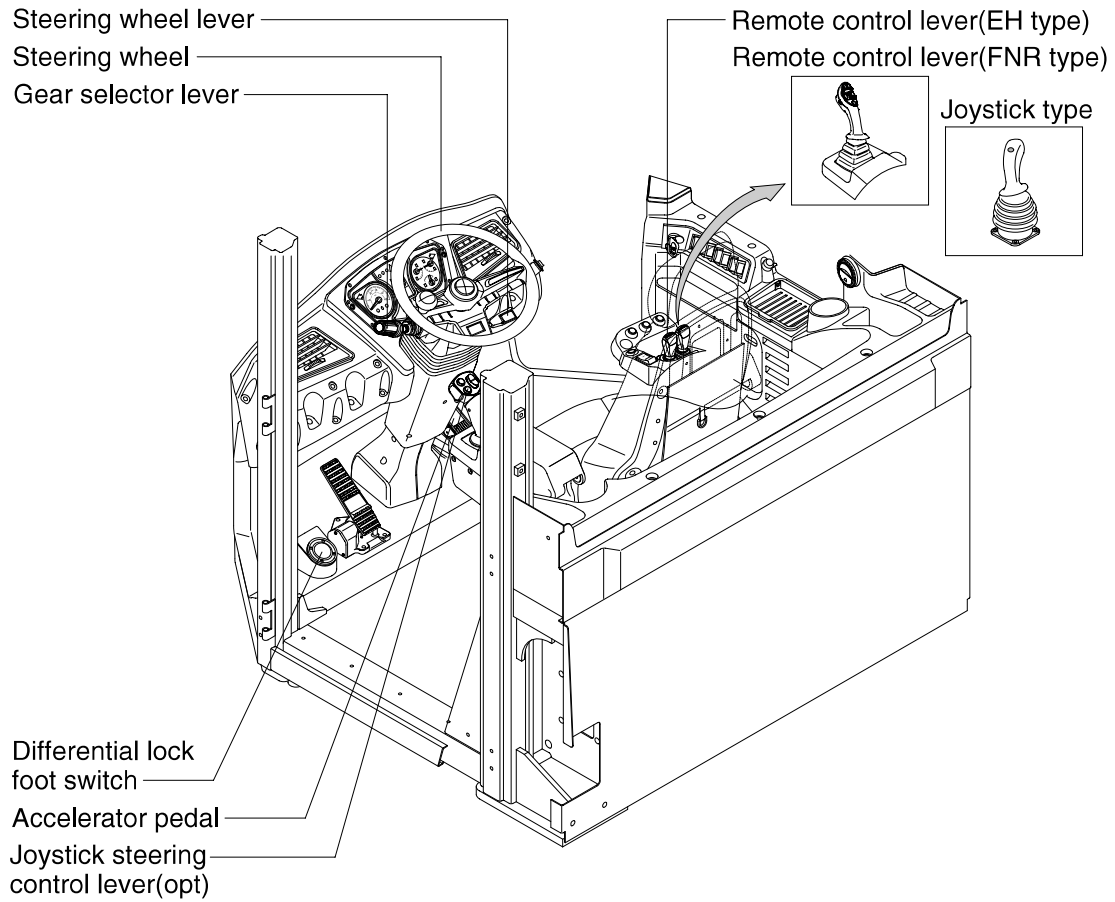

760F3CD28-1

1) REMOTE CONTROL LEVER

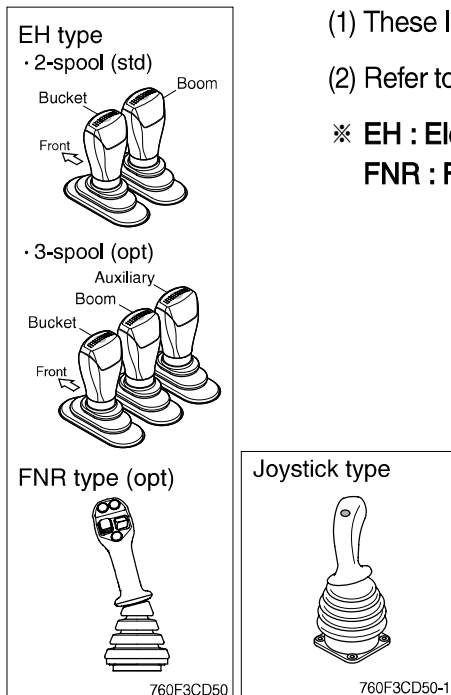

(1) These levers are used to control the boom and the bucket.

(2) Refer to operation of working device in chapter 4 at page 4-9.

※ EH : Electro-hydraulic
 FNR : Forward - Neutral - Reverse

2) GEAR SELECTOR LEVER

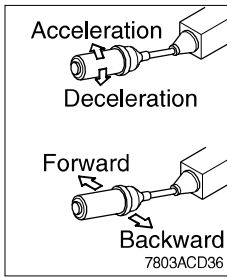

- (1) This lever is used for gear selection, forward 4 stages and reverse 3 stages.
- (2) If you push the gear selector lever, the machine moves forward, but if you pull the gear selector lever, the machine moves backward.
- (3) If you turn the gear selector lever forward, the machine increases the speed, but if you turn the gear selector lever backward, the machine reduces the speed.

3) ACCELERATOR PEDAL

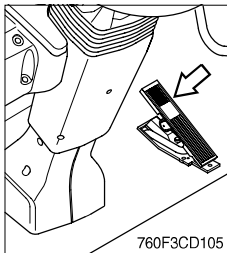

- (1) This pedal controls the engine speed. The engine speed will increase in proportion to the degree of force applied to this pedal.
- (2) Unless this pedal is pressed, the machine will run at low idling.

4) BRAKE PEDAL

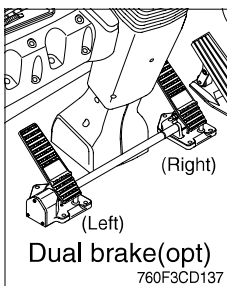
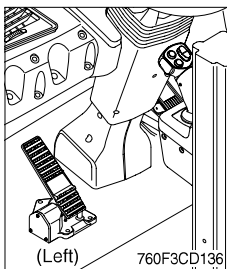

- (1) **Left brake pedal** (service brake + clutch cut off function)
 - ① If the pedal is pushed down, this will generate braking force and bring the machine to a stop.
 - ② If the power train operation is to be cut off, set the clutch cut off mode to ON (L, M, H) and press the pedal.
 - ▲ **Even if the brake is applied while clutch cut off mode is OFF, power train will not cut off.**
 - ※ **Do not operate the machine with foot the brake pedal unnecessarily, or bring premature wear of brake disc.**
 - ③ Clutch cut off function : Refer to page 3-20.
- (2) **Right brake pedal** (service brake function only)
This pedal functions as service brake only.

5) STEERING WHEEL

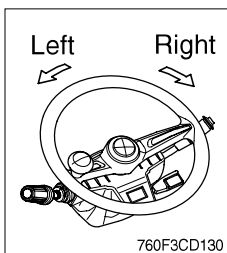

- (1) Two multi-motion cylinders in the center of the machine will operate the steering function.
- (2) If the steering wheel is turned to left, the machine will move to the left and turn it to the right, the machine will move to the right.

6) JOYSTICK STEERING CONTROL LEVER (option)

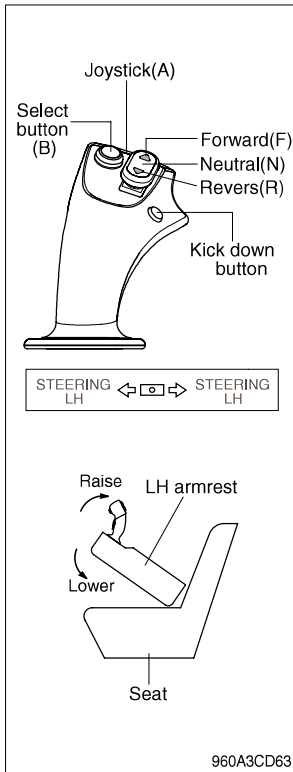

- (1) The system has the following functions concentrated to a collapsible arm rest : steering, forward/reverse drive and kickdown function.
- (2) This means that during normal loading work, the operator does not need to touch the steering wheel.

- (3) The joystick steering pilot lamp on the cluster will be ON when the lever steering is activated.

▲ When operating on a public road, the steering wheel should always be used and the joystick steering be disconnected. Also when operating at high speeds (above 20 km/h) on a work site, always use the steering wheel.

(4) Joystick (A)

- ① Joystick steering can be enabled after following conditions have been satisfied.

- Engine is running. - Operator is seated on the seat.
- LH armrest is placed to the lowered position.
- Gear selector lever is in neutral.
- RCV is deactivated. - Joystick (A) is placed in normal position.
- Parking brake is disengaged, but the machine speed is zero.

- ② After above conditions are met, press the select button (B).

Then joystick steering pilot lamp  on the cluster will be ON and joystick steering can be activated.

- ③ Steering will remain enabled until machine speed is zero and one of the following conditions is met.

- LH armrest is raised. - Parking brake is engaged.
- Gear selector lever is in forward or backward position.
- Operator is not seated on the seat. - Press the select button (B).

※ The steering wheel works as usual, even if the joystick steering is activated.

(5) Forward/reverse selection button

F : Forward drive

N : Neutral

R : Reverse drive

- ① To be able to operate the forward/reverse drive, the system must first be activated using select button (B).

※ **The ordinary gear selector control should be in neutral.**

- ② When this function is engaged, it is possible to operate the forward-reverse drive. If the ordinary gear selector control is activated at the same time as the joystick steering is activated, the ordinary gear selector control overrides any selection made by the joystick steering.

To reactivate the joystick steering, the ordinary gear selector control must first be moved to neutral and the system again be activated.

- ③ The FNR select pilot lamp  on the cluster will be ON when the forward/reverse selection is activated.

(6) Kick-down button : Refer to page 3-47.

7) STEERING WHEEL LEVER

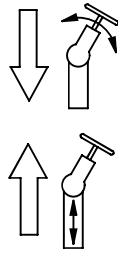
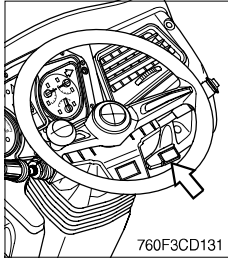

- (1) By pulling down the lever, the wheel is adjustable to tilt.
 - Tilting : 40°
- (2) By pulling up the lever, the wheel is adjustable to telescope.
 - Telescoping : 80 mm

8) DIFFERENTIAL LOCK FOOT SWITCH

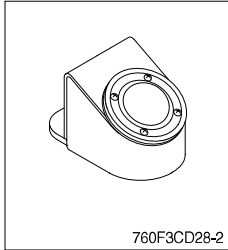

- (1) Press the foot switch for the differential lock function.

You press the foot switch, the differential lock will engage immediately and differential lock pilot lamp lights ON (buzzer sounds).
- (2) Differential lock function is temporarily engaged as long as the operator press the foot switch. When the foot switch is released, differential lock function is disengaged.

6. AIR CONDITIONER AND HEATER

■ FULL AUTO AIR CONDITIONER AND HEATER

Full auto air conditioner and heater system automatically keeps the optimum condition in accordance with operator's temperature configuration sensing ambient and cabin inside temperature.

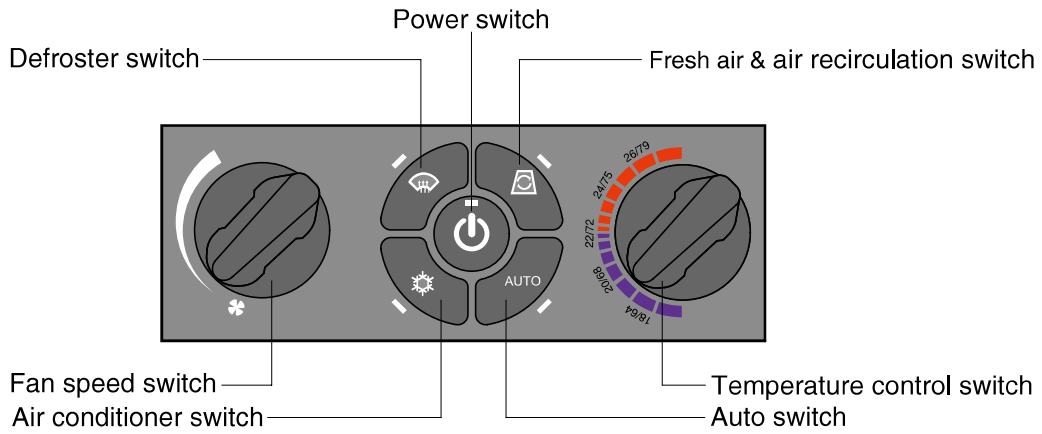

· Location of air outlet

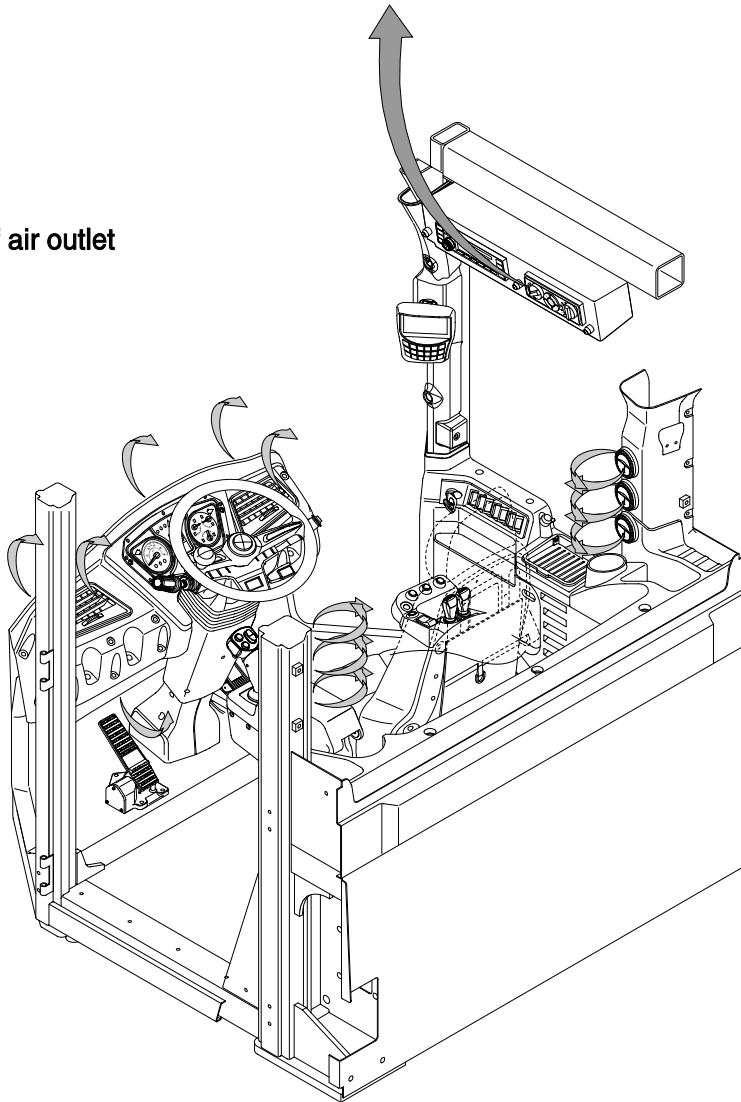

1) POWER SWITCH

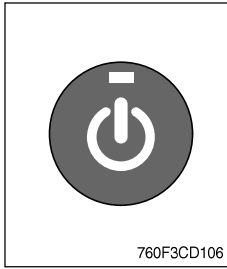

- (1) This switch makes the system ON or OFF.
Just before the power OFF, set values are stored.

(2) Default setting values

Function	Air conditioner	In/outlet	Temperature
Value	OFF	Inlet	Previous sw OFF

※ The green pilot lamp is turned ON.

2) AUTO SWITCH

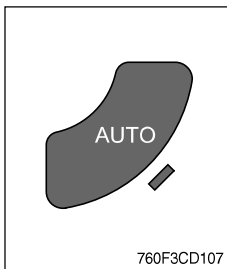

- (1) This switch sets the air conditioner and heater system to automatic temperature control.
Auto air conditioner and heater system automatically keeps the optimum condition in accordance with operator's temperature configuration sensing ambient and cabin inside temperature.

※ The green pilot lamp is turned ON.

3) AIR CONDITIONER SWITCH (compressor switch)

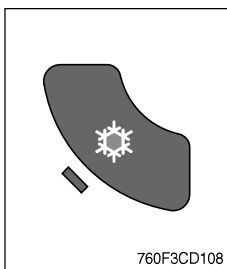

- (1) This switch turns the compressor for the air conditioning.
(2) In accordance with the temperature sensed by duct (evaporator) sensor, compressor turns ON or OFF automatically.

※ **Air conditioner operates to remove vapor and drains water through a drain hose. Water can be sprayed into the cab in case that the drain cock at the ending point of drain hose has a problem.**

In this case, exchange the drain cock.

※ The green pilot lamp is turned ON.

4) DEFROSTER SWITCH

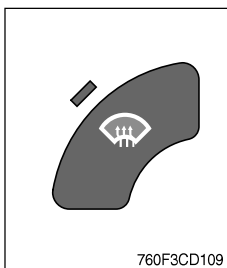

- (1) Defroster and ventilation nozzles at window open and directed toward the windows.

(2) Default setting values

Function	Air conditioner	In/outlet	Blower
Value	ON	Outlet	Max for 15 minutes

※ The green pilot lamp is turned ON.

5) FRESH AIR/AIR RECIRCULATION SWITCH

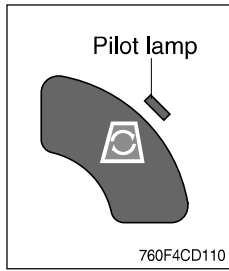

(1) It is possible to change the air-inlet method.

① Fresh air (pilot lamp OFF)

Inhaling air from the outside.

※ **Check out the fresh air filter periodically to keep a good efficiency.**

② Air recirculation (pilot lamp ON)

It recycles the heated or cooled air to increase the energy efficiency.

※ **Change air occasionally when using recirculation for a long time.**

※ **Check out the recirculation filter periodically to keep a good efficiency.**

6) FAN SPEED KNOB

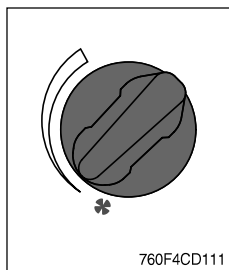

(1) This knob controls fan speed manually.

There are 9 steps to control fan speed.

7) TEMPERATURE CONTROL KNOB

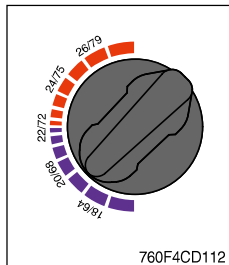

(1) This knob controls the position of the water valve when the air conditioner switch is ON or OFF.

(2) When the AUTO switch is ON, the temperature control knob determines the desired cab temperature. The temperature range is 18°C (64°F) in the full cold position and 26°C (79°F) in the full hot position.

7. OTHERS

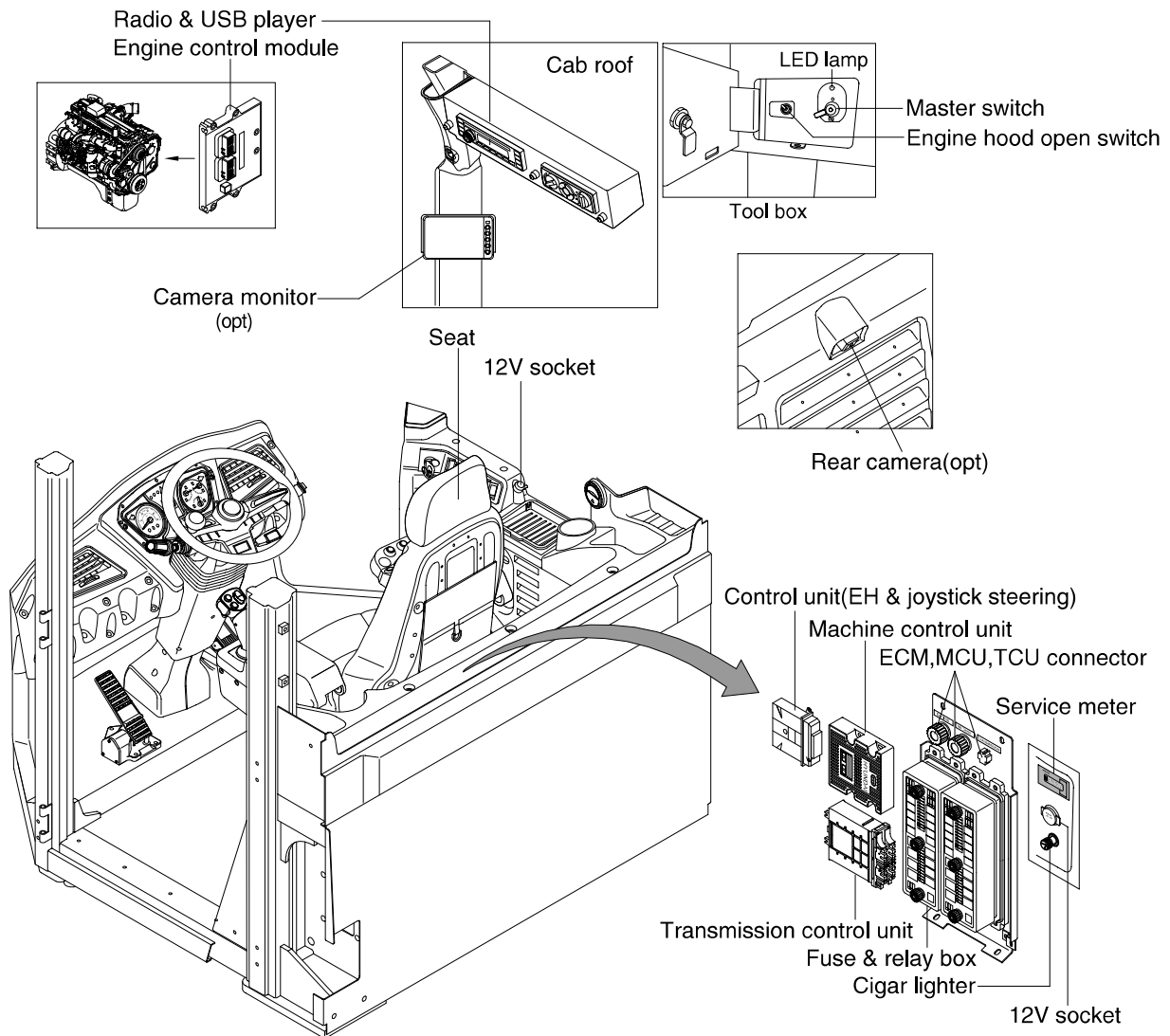

960A3CD38

1) CIGAR LIGHTER

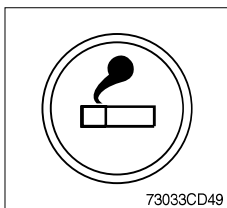

- (1) This can be used when the engine starting switch is ON.
- (2) The lighter can be used when it springs out in a short while after being pressed down.

※ **Service socket**

**Use cigar lighter socket when you need emergency power.
Do not use the lighter exceeding 24 V, 100 W.**

2) SEAT

The seat is adjustable to fit the contours of the operator's body. It will reduce operator fatigue due to long work hours and enhance work efficiency.

- ▲ Always check the condition of the seat belt and mounting hardware before operating the machine.
- ▲ Fail to wear a seat belt during the machine operation may result in serious injury or death in the event of an accident or machine overturn.

(1) Weight and height adjustment

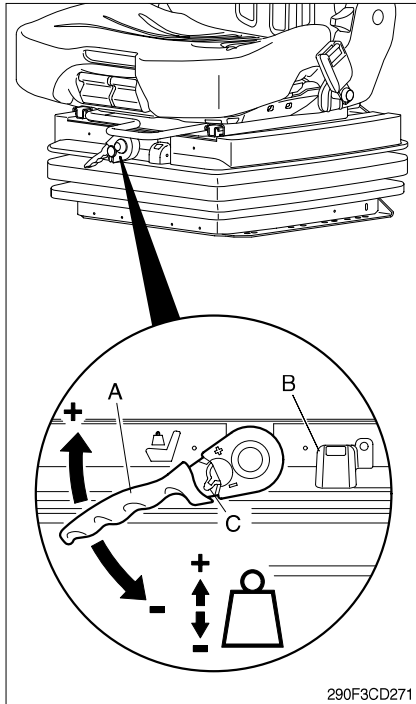

With socket wrench (A) :

- ① The seat has to be adjusted for the operator's weight and height by tilting the handle (+) up or down (-) with the operator not sitting on the seat.
- ② The rotational direction is reversed by toggling the ratchet with the switch (C).
- ③ The operator's weight and the seat height are adjusted correctly when the green marking is completely visible in the indicator window (B) for weight and height.
- ④ The height can be adjusted individually as long as the green marking is visible.

Weight adjustment (AIR SUSPENSION, OPT)

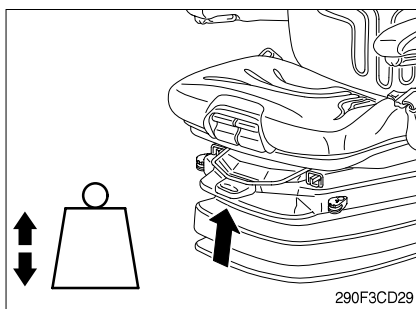

- ① The seat should be adjusted for the operator's weight by briefly pulling the actuator lever of the automatic weight and height adjuster (arrow) with the machine at a standstill and the operator's sitting on the seat.
The operator must sit absolutely still during adjustment.
- ※ Before adjusting the weight, adjust shock absorbers to the position "soft".
 - ※ To prevent damage to the health, the setting for the operator's weight must be checked and adjusted before the machine is operated.

Height adjustment (AIR SUSPENSION, OPT)

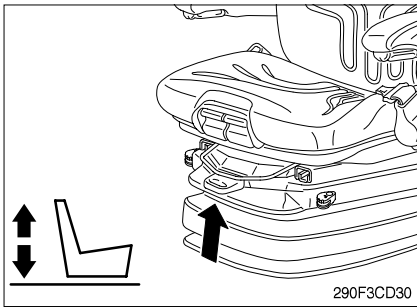

- ① The seat height can be set pneumatically and is continuously adjustable.
 - ② The seat height can be altered by pulling or pressing the actuator lever fully out or in (arrow). If the adjustment reaches the top or bottom endstop, the height is adjusted automatically in order to guarantee a minimum spring travel.
- ※ **Before adjusting the weight, adjust shock absorbers to the position "soft".**
 - ※ **In order to avoid damage, do not operate compressor for more than 1 minute.**

(2) Fore/after adjustment

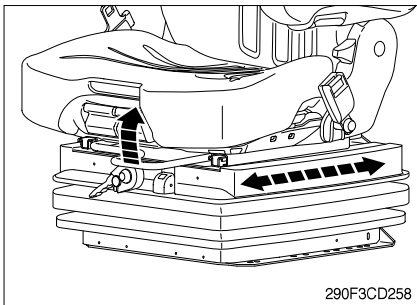

- ① The fore/after adjustment is released by lifting the locking lever.
- ⚠ **Do not operate the locking lever while operating.**
 - ※ **After the adjustment, the locking lever must latch into the desired position with an audible click. It should not be possible to move the operator's seat into another position when it is locked.**
 - ※ **Do not lift the locking lever with your leg or calf.**

(3) Seat depth adjustment

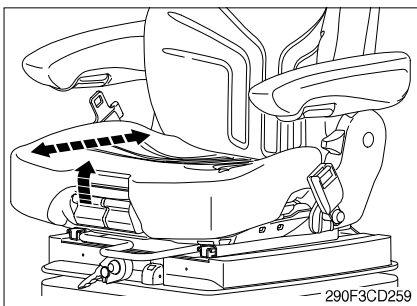

- ① The depth of the seat pan can be individually adjusted.
- ② To adjust the depth of the seat cushion, pull the right handle upwards. By moving the seat pan backwards or forwards the desired seating position can be reached.

(4) Seat pan angle adjustment

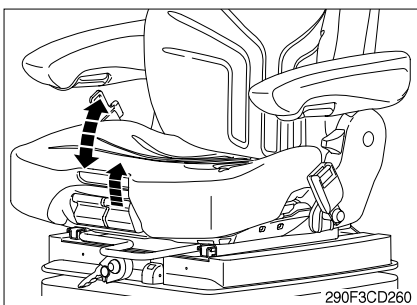

- ① The angle of the seat pan can be individually adjusted.
- ② To adjust the angle of the seat pan, pull the left handle upwards. By exerting pressure on or off the front or rear part of the seat pan it can be moved to the desired angle position.

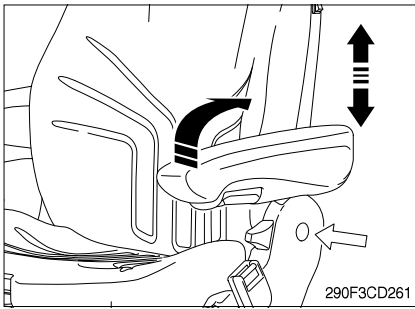

(5) Armrest (LH)

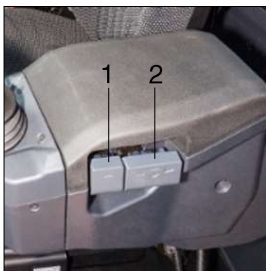

- ① The armrests can be folded up if required and the height can be individually adjusted.
- ② To adjust the armrest for height, separate the round cap (see arrow) from the cover and loosen the hexagon nut (size 13 mm) behind it adjust the armrests to the desired position (5 steps) and tighten the nut again (25 Nm). Replace the cap onto the nut.

Armrest (LH, RH)



1. Tilt lever 
Pull up and hold to tilt armrest maximum 70 degrees.
2. Adjust lever 
Pull up, hold and slide forward or rearward or up or down.

(6) Armrest adjustment

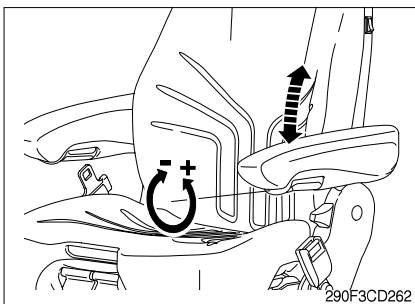

- ① The inclination of the armrest can be modified by turning the adjustment knob.
- ② When turning the knob to the outside (+), the front part of the armrest will be lifted; when turning the knob to the inside (-), it will be lowered.

(7) Headrest

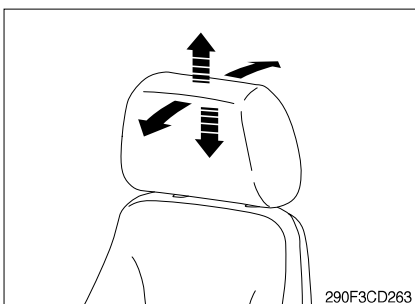

- ① The headrest can be individually adjusted for height by pulling it upward over the various increments up the end stop.
- ② By pushing forwards or rearwards the angle of the headrest can be adjusted individually.
- ③ To remove the headrest, pull it over the end stop.

(8) Document box

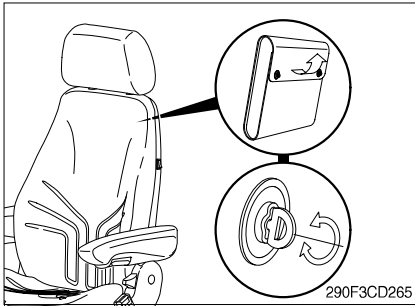

- ① The document box is placed on the rear side of the backrest.
- ② To open the document box, first twist the turn lock closures 90° to the left or the right and then fold the cover of the document box upwards.

(9) Seat heater switch

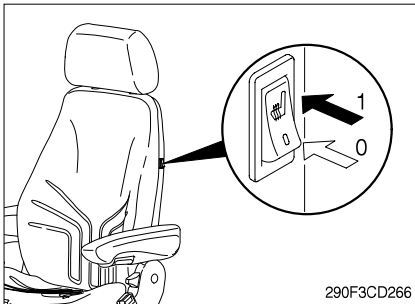

- ① The seat heater can be turned on/off by pressing the switch.

(10) Absorber

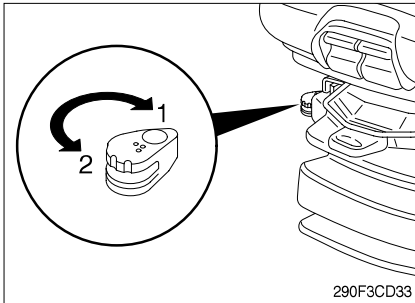

- ① The absorber setting of the seat can be varied to suit the on and off-road working conditions. The cushioning effect can be individually adjusted for this purpose.

Turn the lever to the desired position and release.

- 1 Soft
- 2 Hard

(11) Fore/aft isolator

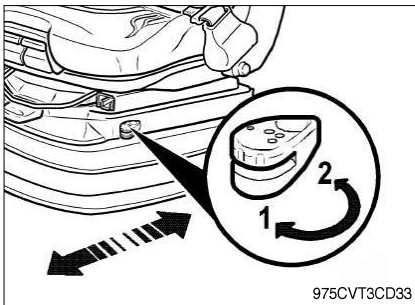

- ① It is useful to activate the fore/aft isolator. This means that shock impacts in the driving direction can be better absorbed by the seat.

- 1 Fore/aft isolator off
- 2 Fore/aft isolator on

(12) Lumbar support

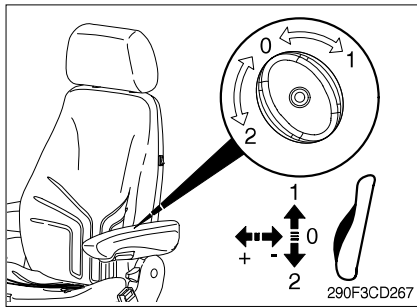

- ① By turning the adjustment knob to the left (2) or right (1), both the height and curvature of the backrest cushion can be individually adjusted.
- ② This increases both the seating comfort and the performance of the operator.

(13) Backrest adjustment

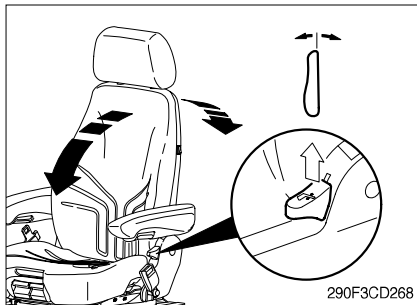

- ① Pull up the locking lever to release the backrest catch. When releasing the backrest, do not load the backrest by pressing against it.
 - ② By exerting pressure on or off the front or rear part of the seat pan it can be moved to the desired position. Release the locking lever to lock the backrest.
- ※ It should not be possible to move the backrest into another position after it has been locked.

(14) Maintenance

Dirt can impair the function of the seat, so make sure you keep your seat clean.

Upholstery does not need to be removed from the seat frame for cleaning.

▲ **Take care with the backrest - it may jerk forward and cause injury. When cleaning the backrest cushion, the backrest must be held in place when operating the backrest lever.**

※ **Do not clean the seat with a pressure washer.**

During cleaning, the upholstery must not be soaked through.

Use standard commercially available upholstery or plastics cleaning agent.

Test first for compatibility on a small, concealed area.

3) 12V SOCKET (option)

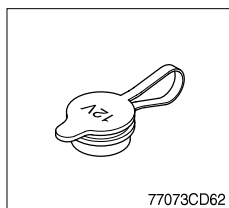

- (1) Utilize the power of 12 V as your need and do not exceed power of 12 V, 30 W.

4) MASTER SWITCH

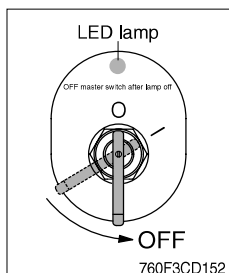

- (1) This switch is used to shut off the entire electrical system.
 - (2) I : The battery remains connected to the electrical system.
O : The battery is disconnected to the electrical system.
- ※ **OFF master switch after LED lamp off.**
- ※ **Never turn the master switch to O (OFF) with the engine running. Engine and electrical system damage could result.**

5) SERVICE METER

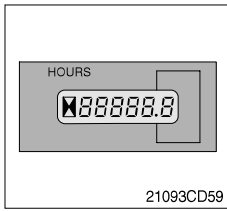

- (1) This meter shows the total operation hours of the machine.
- (2) Always ensure the operating condition of the meter during the machine operation. Inspect and service the machine based on hours as indicated in chapter 6, maintenance.

6) MCU/ECM/TCU CONNECTOR

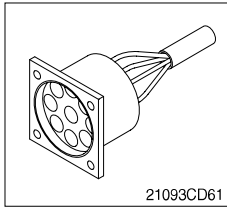

- (1) MCU communicates the machine data with Laptop computer through RS232 service socket.
- (2) ECM communicates the engine data with cummins INSITE adapter through J1939 service socket.
 - ① ECM fault code check
 - ② ECM program change
 - ③ Engine data monitoring & test
- (3) TCU communicates the transmission data with adapter cable.

7) FUSE & RELAY BOX

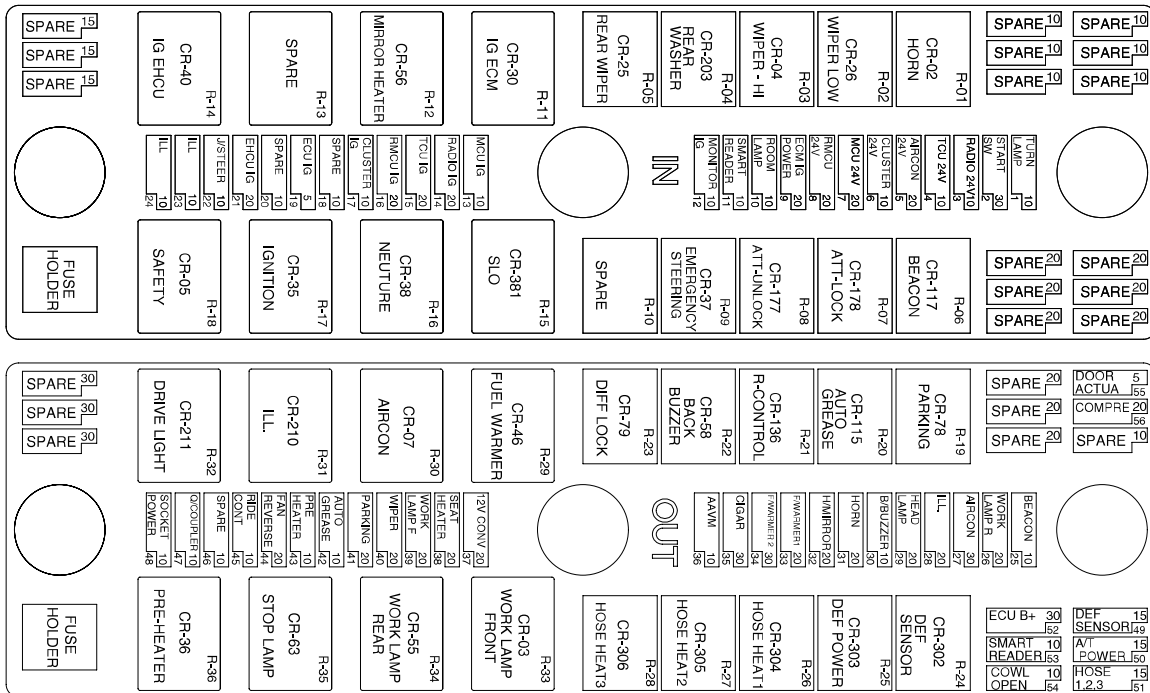

960A3CD55

- (1) The fuses protect the electrical parts and wiring from burning out.
- (2) The fuse box cover indicates the capacity of each fuse and circuit it protects.

※ Replace a fuse with another of the same capacity.

▲ Before replacing a fuse, be sure to turn OFF the starting switch.

8) ENGINE HOOD OPEN TOGGLE SWITCH

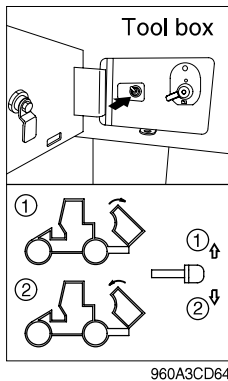

- (1) Move the toggle switch up to position ① in order to open the hood.
- (2) Move the toggle switch down to position ② in order to close the hood.
- (3) Hold the switch until the hood is fully opened or closed. Release the switch. The switch will return to the middle position.

※ Refer to the page 4-28.

※ After stopping the engine, open or close the engine hood.

9) TILT HANDLE (FOR RIGHT SIDE WINDOW)

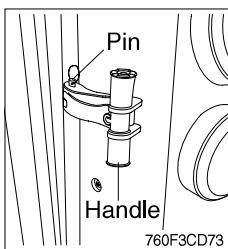

- (1) Pull handle backward and push the handle outward in order to open the window to the partial open position. Remove pin from the handle. Push the window to the fully open position.

※ Open the window periodically in order to ensure proper operation. Lubricate or repair the window as necessary.

10) MACHINE CONTROL UNIT (MCU)

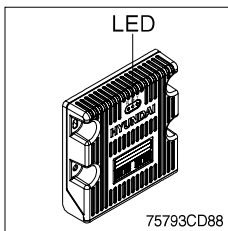

- (1) It consists of electronic parts and controls all lamps and buzzers on cluster in accordance with signals transmitted from the switches, the ECM, TCU, the engine and the hydraulic pressure sensors.
- (2) Three LED lamps on the MCU display as below.

LED lamp	Trouble	Service
G is turned ON	Normal	-
G and R are turned ON	Trouble on MCU	· Change the MCU
G and Y are turned ON	Trouble on serial communication line	· Check if serial communication lines between controller and cluster are disconnected
Three LED are turned OFF	Trouble on MCU power	· Check if the input power wire (24V, GND) of controller is disconnected · Check the fuse

G : green, R : red, Y : yellow

11) TRANSMISSION CONTROL UNIT (TCU)

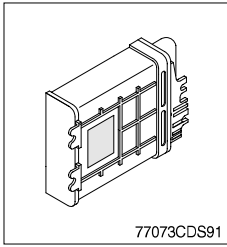

(1) The control unit is shifting the required speeds fully-automatically under consideration of the following criteria.

- Gear selector lever position
- Driving speed
- Load level

12) ENGINE CONTROL MODULE (ECM)

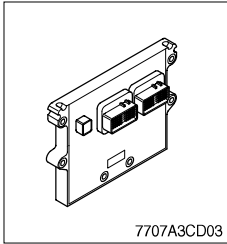

(1) The engine control module (ECM) is the control center of the engine system.

13) CONTROL UNIT (electro hydraulic & joystick steering, EHCU)

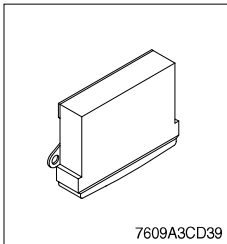

(1) The control unit is the control center of the EH control lever and joystick steering system.

14) REAR CAMERA (option)

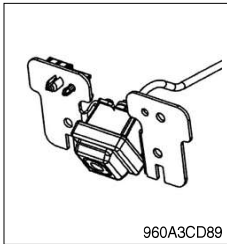

(1) The rear camera is available as a option.

















※ Refer to page 3-35.

15) RADIO AND USB PLAYER (WITH BLUETOOTH)



9403CD100

FRONT PANEL PRESENTATION

- | | |
|---|---|
| <p>1  Power ON/OFF,
Volume UP/DOWN button</p> <p>2  Manual UP/DOWN Tuning,
File search, SEL button</p> <p>3  Mode button,
Audio mute button</p> <p>4  Call & Pair button</p> <p>5  Call end button</p> <p>6  Station preset 1
DIS Display button</p> <p>7  Station preset 2</p> <p>8  Station preset 3
RPT Repeat play button</p> <p>9  Station preset 4
RDM Random play button</p> | <p>10  Station preset 5
DIR- Directory down button</p> <p>11  Station preset 6
DIR+ Directory up button</p> <p>12  Scan play button (SCAN)
Best station memory (BSM) button</p> <p>13  Auto tune up, Seek up button</p> <p>14  Auto tune down, Track down button</p> <p>15  USB connector</p> <p>16  AUX IN Jack</p> <p>17  MIC hole</p> |
|---|---|

■ GENERAL

(1) Power and volume button



① Power ON / OFF button

Press power button (1) to turn the unit on or off.

② Volume UP/DOWN control knob

Turn VOL knob (1) right to increase the volume level.

Turn VOL knob (1) left to decrease the volume.

After 5 seconds the display will return to the previous display mode.

③ Initial volume level set up

I-VOL is the volume level the unit will play at when next turned on. To adjust the I-VOL level, press and hold VOL button (1) for longer than 2 seconds. The current volume level displays on the display panel.

Then turn button (1) right or left to set the volume level as the I-VOL level.

④ Clock ON/OFF control

The CLOCK was default at off status. To turn CLOCK ON, press and hold VOL button (1) for longer than 2 seconds to display I-VOL, then short press VOL again, turn VOL knob while CLOCK OFF display, then the CLOCK ON will be displayed.

※ Due to time tolerance, the clock display on the Audio unit might have little difference.

⑤ Clock adjustment

With CLOCK ON selected, press VOL knob again after CLOCK ON display, the hour will blink, turn VOL knob right or left to adjust hour. Simply press VOL again, the minute will blink, turn VOL knob to adjust minute. Then press VOL again to confirm the clock once finished.

(2) Menu Selection



- ① This button can adjust the sound effect and other things.
Each time you press this button (2), LCD displays as follows :

BAS → TREB → BAL L=R → FAD F=R → EQ → LOUD ON →
BEEP 2ND

On each setting, the level can be controlled by turning TUNE knob (2).
When the last adjustment is made, after 5 seconds, the display will
automatically return to the previous display mode.

② Bass control

To adjust the bass tone level, first select the bass mode by pressing
SEL button (2) repeatedly until BASS appears on the display panel.
Then turn knob (2) right or left within 5 seconds to adjust the bass
level as desired. The bass level will be shown on the display panel
from a minimum of BASS-7 to a maximum of BASS+7.

③ Treble control

To adjust the treble tone level, first select the treble mode by
pressing SEL button (2) repeatedly until TREB appears on the
display panel. Then turn knob (2) right or left within 5 seconds to
adjust the treble level as desired. The treble level will be shown on
the display panel from a minimum of TREB -7 to a maximum of
TREB +7.

④ Balance control

To adjust the left-right speaker balance, first select the balance
mode by pressing SEL button (2) repeatedly until BAL indication
appears on the display panel. Then turn knob (2) right or left within 5
seconds to adjust the balance as desired. The balance position will
be shown by the bars on the display panel from BAL 10R (full right)
to BAL 10L (full left).

⑤ Fader control

To adjust the front-rear speaker balance, first select the fader mode
by pressing SEL button (2) repeatedly until FADER indication
appears on the display panel. Then turn knob (2) right or left within 5
seconds to adjust the front-rear speaker level as desired. The fader
position will be shown by the bars on the display panel from FAD
10F (full front) to FAD 10R (full rear).

⑥ EQ control

You can select an equalizer curve for 4 music types (CLASSIC,
POP, ROCK, JAZZ). Press button (2) until EQ is displayed, then turn
knob (2) right or left to select the desired equalizer curve. Each time
you turn the knob, LCD displays as follows :

EQ OFF → CLASSIC → POP → ROCK → JAZZ

- ※ When the EQ mode is activated, the BASS and TREBLE modes
are not displayed.

⑦ Loud control

When listening to music at low volume levels, this feature will boost the bass and treble response. This action will compensate for the reduction in bass and treble performance experienced at low volume.

To select the loudness feature, press button (2) until LOUD is displayed, then turn knob (2) right or left to activate or deactivate loudness.

⑧ Beep control

To adjust the BEEP mode, first select the BEEP mode by pressing button (2) repeatedly until BEEP indication appears on the display panel. Then turn knob (2) left or right within 5 seconds to select BEEP 2ND, BEEP OFF or BEEP ON.

- BEEP 2ND : You will only hear the beep sound when the buttons are held down for more than 2 seconds.
- BEEP OFF : You can not hear the sound beep when you press the buttons.
- BEEP ON : You can hear the beep sound each time you press the buttons.

(3) Mute control

- ① Press and hold MUTE button (3) for over 2 seconds to mute sound output and MUTE ON will blink on the LCD. Press the button again to cancel MUTE function and resume to normal playing mode.

(4) Mode selection

- ① Repeat press MODE button (3) to switch between FM1, FM2, AM, USB, AUX, BT MUSIC.
- ※ If there is no USB, AUX, Bluetooth Phone connected, it would not display USB, AUX, BT when you press button (3).

■ RADIO

(1) Mode button



- ① Repeat press MODE button to select FM1, FM2 or AM.

(2) Manual tuning button



- ① To manually tune to a radio station, simply turn encoder TUNE (2) left or right to increase or decrease the radio frequency.

(3) Auto tuning button



- ① To automatically select a radio station, simply press Seek up or Track down button.



(4) Station preset button



- ① In radio mode, pressing buttons (6) to (11) will recall the radio stations that are memorized. To store desired stations into any of the 6 preset memories, in either the AM or FM bands, use the following procedure :

- a. Select the desired station.
- b. Press and hold one of the preset buttons for more than 2 seconds to store the current station into preset memory. Six stations can be memorized on each of FM1, FM2, and AM.

(5) Preset scan (PS) / Best station memory (BSM) button



① Press BSM button (12) momentarily to scan the 6 preset stations stored in the selected band. When you hear your desired station, press it again to listen to it.

Press BSM button (12) for longer than 2 seconds to activate the Best Station Memory feature which will automatically scan and enter each station into memory.

※ **If you have already set the preset memories to your favorite stations, activating the BSM tuning feature will erase those stations and enter into the new ones. This BSM feature is most useful when travelling in a new area where you are not familiar with the local stations.**

■ USB PLAYER

(1) USB playback



- ① The unit was equipped with a front USB jack and also a rear USB Jack.

With a USB device plugged in the front USB jack, it will be detected as front USB mode. And with a USB device plugged in the rear USB jack, it will be detected as rear USB. To get to a USB mode, press MODE (3) button momentarily or insert the USB device in front or rear USB jack.

- ※ If no mp3 or wma files in USB device, it will convert to the previous mode after display NO FILE.

(2) Track Up / Down button



- ① Press SEEK up (13) or TRACK down (14) to select the next or previous track. Press and hold the buttons to advance the track rapidly in the forward or backward direction.



(3) MP3 directory / File searching



- ① Button (2) is used to select a particular directory and file in the device. Turn button (2) right or left to display the available directories. Press button (2) momentarily when the desired directory is displayed, then turn button (2) right or left again to display the tracks in that directory. Press button (2) to begin playback when the desired file is displayed.

(4) Directory Up / Down button



- ① During MP3/WMA playback, simply press DIR- button (10) to select the previous directory (if available in the device); simply press DIR+ button (11) to select the next directory (if available in the device).

- ※ If the USB device does not contain directories, it would play MP3/WMA tracks at 10- file when you press DIR- button (10), and play MP3/WMA tracks at 10+ file when you press DIR+ (11) button.

(5) Track Scan Play (SCAN) button

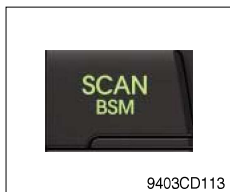

- SCAN playback : Simply press SCAN (12) button to play the first 10 seconds of each track.
- SCAN folder : Press and hold SCAN button for longer than 2 seconds to scan play the tracks in current folder.
- SCAN off : Simply press it again to cancel SCAN feature.

(6) Track Repeat Play (RPT) button



- REPEAT playback : Simply press RPT (8) button to play current track repeatedly.
- REPEAT folder : Press and hold RPT for longer than 2 seconds to repeat play the tracks in current folder.
- REPEAT off : Simply press it again to cancel REPEAT feature.

(7) Track Random Play (RDM) button



- RANDOM playback : Simply press RDM (9) button to play the tracks in the device in a random sequence.
- RANDOM folder : Press and hold RDM button for longer than 2 seconds to random play the tracks in current folder.
- RANDOM off : Simply press it again to cancel RANDOM feature.

(8) ID3 v2 (DISP)



- ① While a MP3 file is playing, press DISP button (6) to display ID3 information. Repeat push DISP button (6) to show directory name / file name and album name / performer / title.

※ If the MP3 disc does not have any ID3 information, it will show NO ID3.

* USB Information and Notice

a. Playback FILE SYSTEM and condition allowance.

- FAT, FAT12, FAT16 and FAT32 in the file system.
- V1.1, V2.2 and V2.3 in the TAG (ID3) version.

b. Display up to 32 characters in the LCD display.

c. No support any of MULTI-CAED Reader.

d. No high speed playback but only playing with normal full speed.

※ DRM files in the USB may cause malfunction to playback in the radio unit.

※ The temperature below -10 Celsius, the audio unit with USB hook up would be affected to play well.

■AUX OPERATION

It is possible to connect your portable media player to the audio system for playback of the audio tracks via the cab speakers.

To get the best results when connecting the portable media to the audio system, follow these steps :

- Use a 3.5 mm stereo plug cable to connect the media player headphone socket at each end as follows.
 - Adjust the portable media player to approximately 3/4 volume and start playback.
 - Press the MODE button (3) on the audio unit to change into AUX mode.
 - The volume and tone can now be adjusted on the audio unit to the desired level.
- ※ **The audio quality of your media player and the audio tracks on it may not be of the same sound quality as the audio system is CD Player.**
- ※ **If the sound of the media player is too low compared with the radio or CD, increase the volume of the player.**
- ※ **If the sound of the media player is too loud and/or distorted, decrease the volume of the player.**
- ※ **When in AUX mode, only the Volume, Bass, Treble, EQ and Mode functions of the audio unit can be used.**

■ BLUETOOTH (if equipped)

1) Using a bluetooth wireless connection

- (1) Your audio unit supports bluetooth wireless technology. You can set up a wireless link with bluetooth cellular phone.
 - (2) Keep PAIRING the cellular phone with audio unit in a few minutes as the phone are being switched on well enough.
- ※ Since this audio unit is on standby to connect with your cellular phone via bluetooth wireless technology, using this audio unit without running the engine can result battery drainage.
 - ※ This audio unit phone call reception is on standby when ignition switch is set to ACC OFF or ON.
 - ※ The line-of-sight distance between this audio unit and your cellular phone must be 10 meters or less for sending and receiving voice and data via bluetooth wireless technology. However the transmission distance may become shorter than the estimated distance depending on the environment in use.
 - ※ Digital Noise & Echo suppression system provides the best sound clarity with little or no distortion (Echo & side tone will happen depending on cellular phone or service network).
 - ※ To ensure the quality of calling, you should select a proper bluetooth VR level. This audio unit has already set with the best bluetooth VR level.

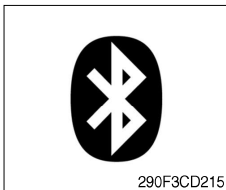

① Bluetooth icon

It will blink while establishing the bluetooth pairing.
It will light after a bluetooth device connected.

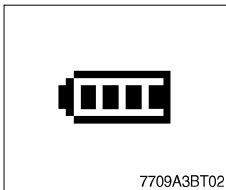

② Battery icon

It indicates the battery status of the connected bluetooth device.

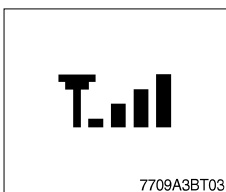

③ Single strength icon

It indicates the signal strength of the connected bluetooth device.

2) Pairing in hands free modes



- (1) Press and hold CALL button (4) for 2 seconds until you hear beep sound, then appears PAIR STR on the display.
- (2) For the next procedure, go to cellular phone pairing mode.
- (3) If it is in pairing status with audio unit and cellular phone, PAIRING will show on the display.
- (4) If you want to exit pairing mode, press CALL END button (5) briefly while pairing, then it will show PAIR CLR on the display.
- (5) Bluetooth Icon and PAIR OK appear on the display when pairing is successful.

3) Cellular phone pairing mode

- (1) Browse your cellular phone menu and find the connectivity or bluetooth connection section.
 - (2) Select search for a new handsfree device function and allow the phone to find the mobile.
 - (3) HYUNDAI should appear on your cellular phone screen.
 - (4) Press connect menu among the handsfree option on your cellular phone.
 - (5) The cellular phone should prompt for a pin code. Insert the pin code 0000.
 - (6) The cellular phone should confirm that it has established a new paired connection.
 - (7) Close the menu. The pairing is now completed. It appears PAIR FAIL on the display for 3 seconds.
- ※ **Each cellular phone type has distinct phone menu so you may need to refer to your manufactures instruction for the correct procedure on how to connect a new bluetooth device.**
 - ※ **Please retry to the pairing instruction if HYUNDAI does not appear on the cellular phone screen.**
 - ※ **Please select authorized, if there is authorized menu in the menu of bluetooth connection in your cellular phone.**
 - ※ **Once the bluetooth pairing is completed between your cellular pone and this audio unit, the both units will be automatically recognized on its paring and when you turn on the key in your car even though this audio unit is turned off.**
 - ※ **This audio unit can store up to 6 phones pairings. If the memory is full, the first stored paired phone will be deleted.**
 - ※ **The connecting priority will be given to the last connected cellular phone.**
 - ※ **If you want to change the connecting priority, try to connect this audio unit from the cellular phone.**

4) Bluetooth connection and disconnection

- (1) When established bluetooth connection between this audio unit and the cellular phone, bluetooth icon on the display appears and then the display shows HF/AV CONN when handsfree & AV profile connected.



- (2) To disconnect bluetooth link
Press and hold CALL END button (4) for 2 seconds, it shows DIS CON and disappears bluetooth Icon on the display.



- (3) To disconnect bluetooth link
Press CALL button (3) briefly, it blinks bluetooth Icon on the display while bluetooth is being connected. If the connection is completed, it appears bluetooth Icon on the display.

- ※ When your cellular phone battery is at low charge, the bluetooth connection may occasionally be lost. To maintain good connectivity ensure that your phone battery is adequately charged.
- ※ In case of failure of bluetooth pairing :
 - Delete item in paired list on your phone.
 - Reset both phone by power off/on and the audio unit by ACC off/on.
- ※ Connecting priority of handsfree profile is higher than headset profile.
- ※ The headset mode does not support caller ID, reject call and call Transfer.

5) Using the audio unit as a handsfree device

- (1) When the audio unit is ringing, it shows CALL and follows with the phone number ***** on the display.



- (2) To accept call
Press CALL button (4), it appears ANSWER CALL and follows TALKING on the display.
- (3) To end call
To end call, press CALL END button (5), it appears REJECT on the display.
- ※ If reject call is activated in your phone, then your cellular phone does not support reject call function.

6) Audio transfer between the audio unit and phone

The audio transfer function is for switching the call from the audio unit to the cellular phone for private conversation.



(1) Press CALL button (4) briefly during conversation, it appears CALL TRANS on the display. To switch back to the audio unit, press button (4) briefly during private conversation, then it appears CALL TRANS on the display again.

- ※ **This function will be a cause of disconnection of bluetooth link in some nokia phones, but you do not worry just press button (4) during private conversation, then switch back to the audio unit automatically.**
- ※ **The quality of calling between cellular phone and audio unit is better than calling between one audio unit and another one.**

7) Last call number dialing



(1) Press CALL button (4) briefly, it appears CALL TO, then simply press CALL button once again, it would make the last call with phone number display on LCD.

If Reject call is activated in your phone, then your cellular phone does not support Reject Call function.

- ※ **If you are using SAMSUNG phone, then you may need to press once more send button. First press button shows phone contact list in your phone, then second press make the last call.**

8) To make a call by cellular phone

The audio transfer function is for switching the call from the audio unit to the cellular phone for private conversation.

- (1) The audio unit activated automatically when you make a call by cellular phone.
- (2) When you make a call processing by cellular phone, it shows CALLING on the display.
- (3) When you receive a call, the phone number ***** appears on the display.

9) Using the audio unit as bluetooth music

The audio unit supports A2DP (Audio Advanced Distribution Profile) and AVRCP (Audio Video Remote Control Profile), and both profiles are available to listen music at the audio unit via cellular phone which is supporting the two profiles above.

(1) To play music, search the menu on your cellular phone as below :

i.e : Menu → File manager → Music → Option → Play via bluetooth.

It appears BT MP3 on the display.

(2) During BT MP3 playing, you could select the previous or next track by pressing SEEK up or TRACK down button on audio unit or operate via your cellular phone.

(3) To stop music, press button (5) briefly and it will automatically switch into the previous mode.

(4) To resume music playing, press the play button on your cellular phone.

※ This function maybe different depends on cellular phone. Please follow the cellular phone menu. Some kinds of phone need to pair once more for bluetooth MP3 connection.



※ This function will be caused to disconnect A2DP, AVRCP depends on cellular phone.

※ Information about songs (e.g.: the elapsed playing time, song title, song index, etc.) cannot be displayed on this audio unit.

■ RESET AND PRECAUTIONS

1) Reset function

Interfere noise or abnormal compressed files in the MP3 disc or USB instrument may cause extraordinary operation (or unit frozen/locking up). It's strongly recommended to use appropriate USB storage not cause any malfunction to the audio unit. In the unlikely event that the player fails to operate correctly, try out to reset unit by any of following two methods.

(1) press and hold   simultaneously for about 5 seconds. (without Bluetooth)

Press and hold   simultaneously for about 5 seconds. (with Bluetooth)

(2) Take out the fuse for the audio system in the vehicle once and then plug again.

※ It will be necessary to re-enter the radio preset memories as these will have been erased when the microprocessor was reset.

After resetting the player, ensure all functions are operation correctly.

2) Precautions

When the inside of the car is very cold and the player is used soon after switching on the heater, moisture may form on the disc or the optical parts of the player and proper playback may not be possible.

If moisture forms on the optical parts of the player, do not use the player for about one hour. The condensation will disappear naturally allowing normal operation.

(1) Operation voltage : 9~32 volts DC, negative

(2) Output power : 40 watts maximum (20 watts x 2 channels)

(3) Tuning range

Area	Band	Frequency range	Step
USA	FM	87.5~107.9 MHZ	200K
	AM	530~1710 KHZ	10K
EUROPE	FM	87.5~108.0 MHZ	50K
	AM	522~1620 KHZ	9K
ASIA	FM	87.5~108.0 MHZ	100K
	AM	531~1602 KHZ	9K
LATIN	FM	87.5~107.9 MHZ	100K
	AM	530~1710 KHZ	10K

● AREA Selection :

- To select an area, press and hold related buttons at FM1 band for about 3 seconds.
- USA Area: Press and hold mode + 1DIS buttons for 3 seconds
- EUROPE Area: Press and hold mode + 2 buttons for 3 seconds
- ASIA Area: Press and hold mode + 3RPT buttons for 3 seconds
- LATIN Area: Press and hold mode + 4RDM buttons for 3 seconds.

(4) USB version : USB 1.1

(5) Bluetooth version : V2.1

(6) Bluetooth supported profile :





- A2DP : Advanced Audio Distribution Profile
- AVRCP : Audio/Video Remote Control Profile
- HFP : Hands-Free Profile

16) CAMERA MONITOR (OPTION)





960A3CD65

(1) Front panel description

Button	Description	Single Cam mode	Function menu - Single Cam	AAVM mode	Function menu - AAVM
	POWER	- Beep stop - Display On / Off	- Beep stop - Display On / Off - Menu escape (save & exit)	- Beep stop * - Display On / Off	- Beep stop - Display On / Off - Menu escape (save & exit)
	SELECT	Parking guide line On / Off	- Menu select - Adjust menu escape	Favorite view (menu preset)	- Menu select - Adjust menu escape
	MENU	- Menu enter - Parking guide line adjust (long key/2 sec)	Menu next page	Menu enter	Menu next page
	UP	- Previous view (short key) - Adjust to the volumn set in the menu (long key)	- Menu Up - Menu Adjust Up	- Previous view (short key) - Adjust to the volumn set in the menu (long key)	- Menu up - Menu adjust up
	DOWN	Next view	- Menu Down - Menu Adjust down	Next view	- Menu down - Menu adjust down

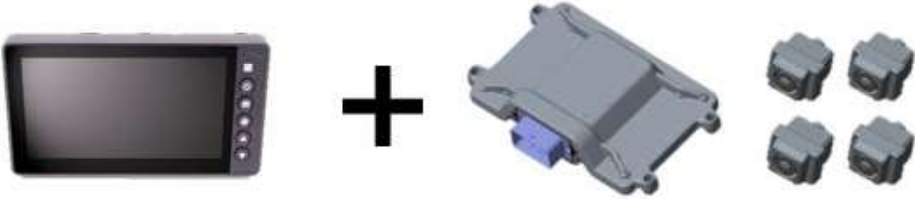
(2) Interlocked with other devices

CASE 1	
Monitor + Rear cam	
CASE 2	
Monitor + AAVM	
CASE 3	
Monitor + Rear cam + Radar	
CASE 4	
Monitor + AAVM + Radar	

960A3CD71

(3) Operation scenario (Single camera mode)

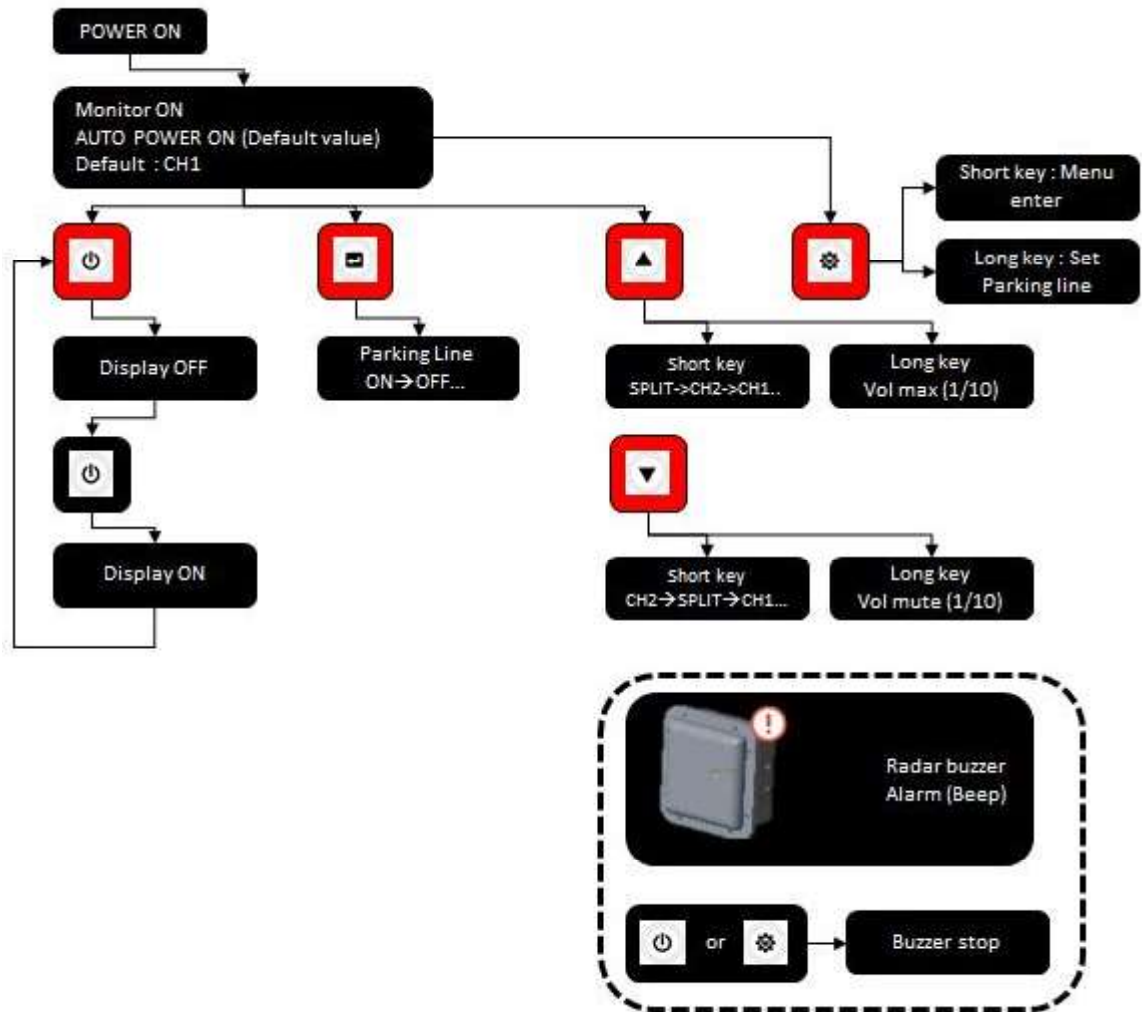

960A3CD72

(4) Operation scenario (AAVM mode)



	POWER
	ENTER
	MENU
	UP
	DOWN

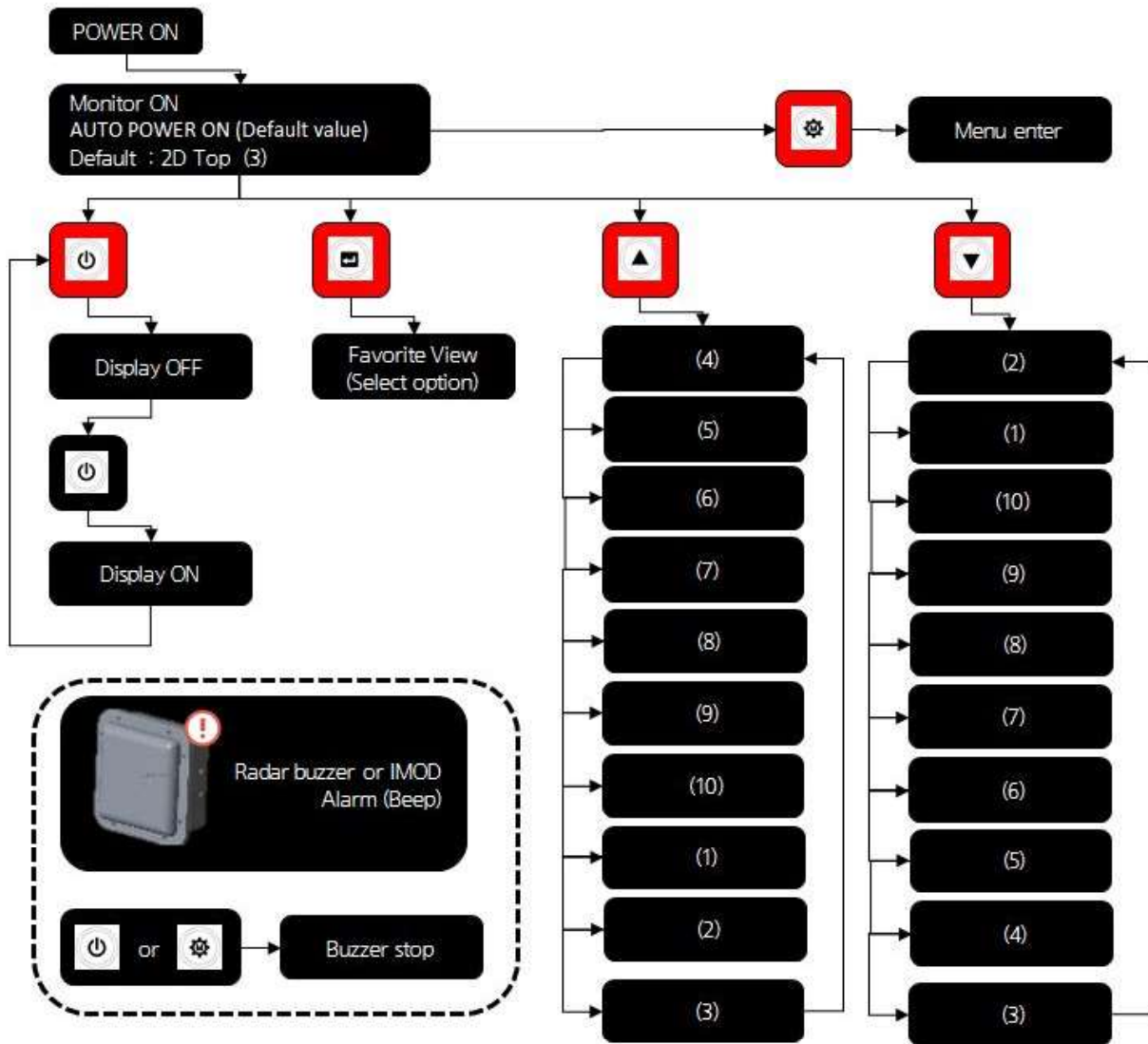

960A3CD73

(5) AAVM view mode type

NO	Name
1	3D TOP
2	3D Rear
3	2D TOP
4	3D LEFT
5	3D RIGHT
6	4CH
7	RIGHT
8	LEFT
9	REAR
10	FRONT

UP & DOWN KEY ORDER



- UP : 1 → 2 → 3 → 4 → 5 → 6 → 7 → 8 → 9 → 10
- DOWN : 10 → 9 → 8 → 7 → 6 → 5 → 4 → 3 → 2 → 1

960A3CD74

(6) Function menu tree (Single cam mode)

SHORT KEY					
NO	MENU	Pop-up menu	Background video	SETTING VALUE	비고
1	SCREEN COLOR SETTING	<ul style="list-style-type: none"> ■ SCREEN COLOR SETTING ▣ BRIGHT : 20 ▣ CONTRAST : 33 ▣ COLOR : 30 ▣ SHARPNESS : 30 ▣ TINT : 30 	Previous view	BRIGHT : 0~60 / 1STEP	Default : 20
				CONTRAST : 0~60 / 1STEP	Default : 33
				COLOR : 0~60 / 1STEP	Default : 30
				SHARPNESS : 0~60 / 1STEP	Default : 30
				TINT : 0~60 / 1STEP	Default : 30
2	CAMERA1 SETTING	<ul style="list-style-type: none"> ■ CAMERA1 SETTING ▣ MIRROR : OFF ▣ UPSIDE DOWN : OFF ▣ TRIGGER ENABLE : ON ▣ TRIGGER SUSTAIN : 02sec ▣ MARKER DISPLAY : OFF ▣ MARKER TYPE : TypeA ▣ MARKER POSITION : Enter 	CAMERA 1	MIRROR : ON/OFF	
				UPSIDE DOWN : ON / OFF	
				TRIGGER ENABLE : ON / OFF	
				TRIGGER SUSTAIN : 1~20 sec / 1sec	
				MARKER DISPLAY : ALWAYS / TRIGGER / OFF	
				MARKER TYPE : TYPE A / TYPE B	
				MARKER POSITION : ENTER	MARKR WIDTH / HIGHT ADJUST
3	CAMERA2 SETTING	<ul style="list-style-type: none"> ■ CAMERA2 SETTING ▣ MIRROR : OFF ▣ UPSIDE DOWN : OFF ▣ TRIGGER ENABLE : ON ▣ TRIGGER SUSTAIN : 02sec ▣ MARKER DISPLAY : OFF ▣ MARKER TYPE : TypeA ▣ MARKER POSITION : Enter 	CAMERA 2	MIRROR : ON/OFF	
				UPSIDE DOWN : ON/OFF	
				TRIGGER ENABLE : ON/OFF	
				TRIGGER SUSTAIN : 1~20 sec / 1sec	
				MARKER DISPLAY : ALWAYS / TRIGGER / OFF	
				MARKER TYPE : TYPE A / TYPE B	
				MARKER POSITION : ENTER	MARKR WIDTH / HIGHT ADJUST
4	SPLIT1 SETTING	<ul style="list-style-type: none"> ■ SPLIT1 SETTING ▣ SPLIT TYPE : TypeA ▣ CH1 : CAM1 ▣ CH2 : CAM2 	SPLIT VIEW	SPLIT TYPE : TYPE A / TYPE B	
				CH1 : CAM1/CAM2	
				CH2 : CAM1/CAM2	
5	SYSTEM CONFIG	<ul style="list-style-type: none"> ■ SYSTEM CONFIG ▣ AUTO POWER : AUTO ▣ AUTO DIMMER : OFF ▣ BEEP VOLUME : 05 ▣ LANGUAGE : ENGLISH ▣ FACTORY RESET : Ver0.55/1.33 	SPLIT VIEW	AUTO POWER : AUTO / ON / OFF	
				AUTO DIMMER : ON / OFF	
				BEEP VOLUME : 0~10 / 1 STEP	Default : 5
				LANGUAGE : 한국어 / ENGLISH	Default : ENGLISH
				FACTORY RESET : Version	

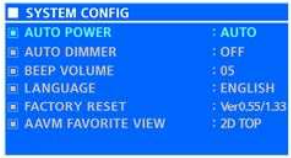
(7) Function menu tree (AAVM mode)

SHORT KEY					
NO	MENU	Pop-up menu	Background video	SETTING VALUE	비고
1	SCREEN COLOR SETTING		Previous view	BRIGHT : 0~60 / 1STEP	Default : 20
				CONTRAST : 0~60 / 1STEP	Default : 33
				COLOR : 0~60 / 1STEP	Default : 30
				SHARPNESS : 0~60 / 1STEP	Default : 30
				TINT : 0~60 / 1STEP	Default : 30
3	SYSTEM CONFIG		Previous view	AUTO POWER : AUTO / ON / OFF	
				AUTO DIMMER : ON / OFF	
				BEEP VOLUME : 0~10 / 1 STEP	Default : 5
				LANGUAGE : 한국어 / ENGLISH	Default : ENGLISH
				FACTORY RESET : Version	
				Favorite view : [Click]AAVM View mode	Displayed when AAVM is installed Default : 4ch (6)
4	RADAR SETTING		Previous view	RADAR DISPLAY : ON/OFF	Enable menu when radar mounted
				RADAR AUTO TRIGGER : ON / OFF	<ul style="list-style-type: none"> •Activate menu with radar and AAVM •Non-adjustable when radar is not installed* •Can not be set when Radar Display off* •Default : ON

(8) Parking guide line adjust

❖ How to Enter

 → LONG KEY (2sec)	<table border="1"> <thead> <tr> <th colspan="2">CAMERA1 SETTING</th> <th colspan="2">CAMERA2 SETTING</th> </tr> </thead> <tbody> <tr> <td>▶ MIRROR</td> <td>: OFF</td> <td>▶ MIRROR</td> <td>: OFF</td> </tr> <tr> <td>▶ UPSIDE DOWN</td> <td>: OFF</td> <td>▶ UPSIDE DOWN</td> <td>: OFF</td> </tr> <tr> <td>▶ TRIGGER ENABLE</td> <td>: ON</td> <td>▶ TRIGGER ENABLE</td> <td>: ON</td> </tr> <tr> <td>▶ TRIGGER SUSTAIN</td> <td>: 02sec</td> <td>▶ TRIGGER SUSTAIN</td> <td>: 02sec</td> </tr> <tr> <td>▶ MARKER DISPLAY</td> <td>: OFF</td> <td>▶ MARKER DISPLAY</td> <td>: OFF</td> </tr> <tr> <td>▶ MARKER TYPE</td> <td>: TypeA</td> <td>▶ MARKER TYPE</td> <td>: TypeA</td> </tr> <tr> <td>▶ MARKER POSITION</td> <td>: Enter</td> <td>▶ MARKER POSITION</td> <td>: Enter</td> </tr> </tbody> </table>	CAMERA1 SETTING		CAMERA2 SETTING		▶ MIRROR	: OFF	▶ MIRROR	: OFF	▶ UPSIDE DOWN	: OFF	▶ UPSIDE DOWN	: OFF	▶ TRIGGER ENABLE	: ON	▶ TRIGGER ENABLE	: ON	▶ TRIGGER SUSTAIN	: 02sec	▶ TRIGGER SUSTAIN	: 02sec	▶ MARKER DISPLAY	: OFF	▶ MARKER DISPLAY	: OFF	▶ MARKER TYPE	: TypeA	▶ MARKER TYPE	: TypeA	▶ MARKER POSITION	: Enter	▶ MARKER POSITION	: Enter
CAMERA1 SETTING		CAMERA2 SETTING																															
▶ MIRROR	: OFF	▶ MIRROR	: OFF																														
▶ UPSIDE DOWN	: OFF	▶ UPSIDE DOWN	: OFF																														
▶ TRIGGER ENABLE	: ON	▶ TRIGGER ENABLE	: ON																														
▶ TRIGGER SUSTAIN	: 02sec	▶ TRIGGER SUSTAIN	: 02sec																														
▶ MARKER DISPLAY	: OFF	▶ MARKER DISPLAY	: OFF																														
▶ MARKER TYPE	: TypeA	▶ MARKER TYPE	: TypeA																														
▶ MARKER POSITION	: Enter	▶ MARKER POSITION	: Enter																														
Menu BUTTON LONG KEY Enter	CAMERA 1, 2 SETTING [MARKER POSITION] SELECT and Enter																																

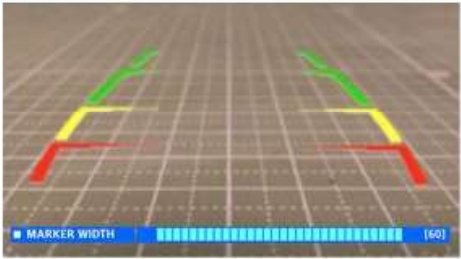
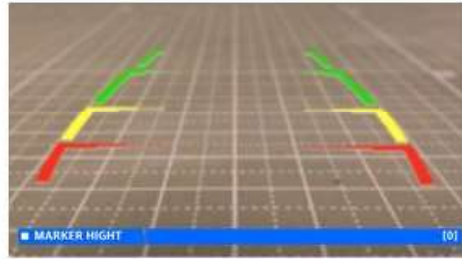
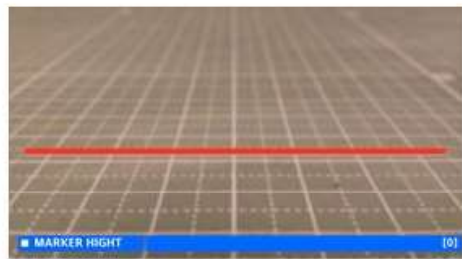

■ MARKER WIDTH		[60]
■ MARKER HIGHT		[0]

TYPE A		
TYPE B		
<ol style="list-style-type: none"> 1. To set the parking line, [MARKER DISPLAY: ALWAYS or TRIGGER] must be set in Camera 1 or Camera 2 setting. 2. In other modes, the parking line can not be set. 3. [MARKER DISPLAY : OFF] <ol style="list-style-type: none"> 1. The parking line positioning menu should not be selected. 2. Do not enter LONG KEY with the menu button. 		

(9) How to set function menu

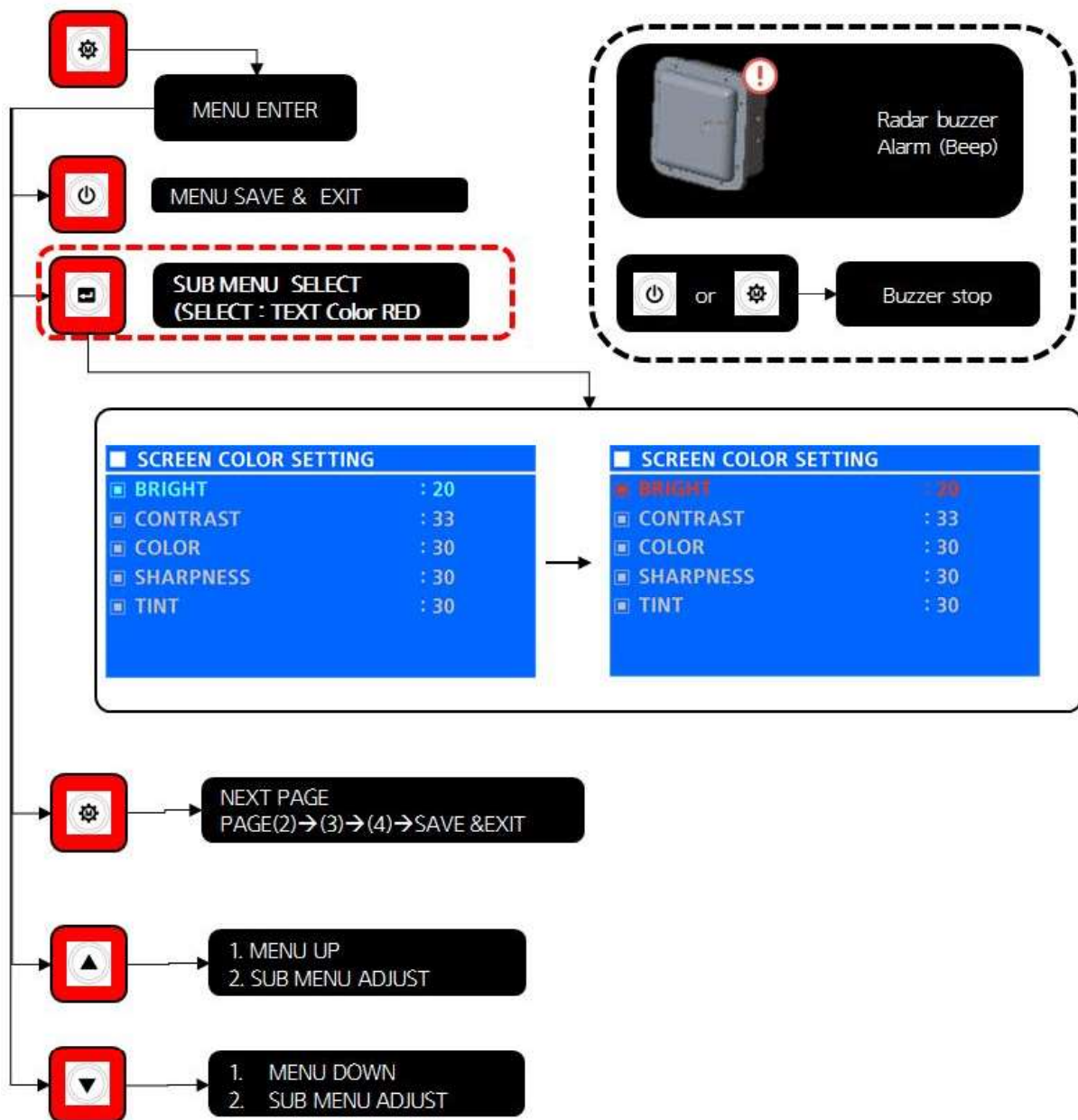

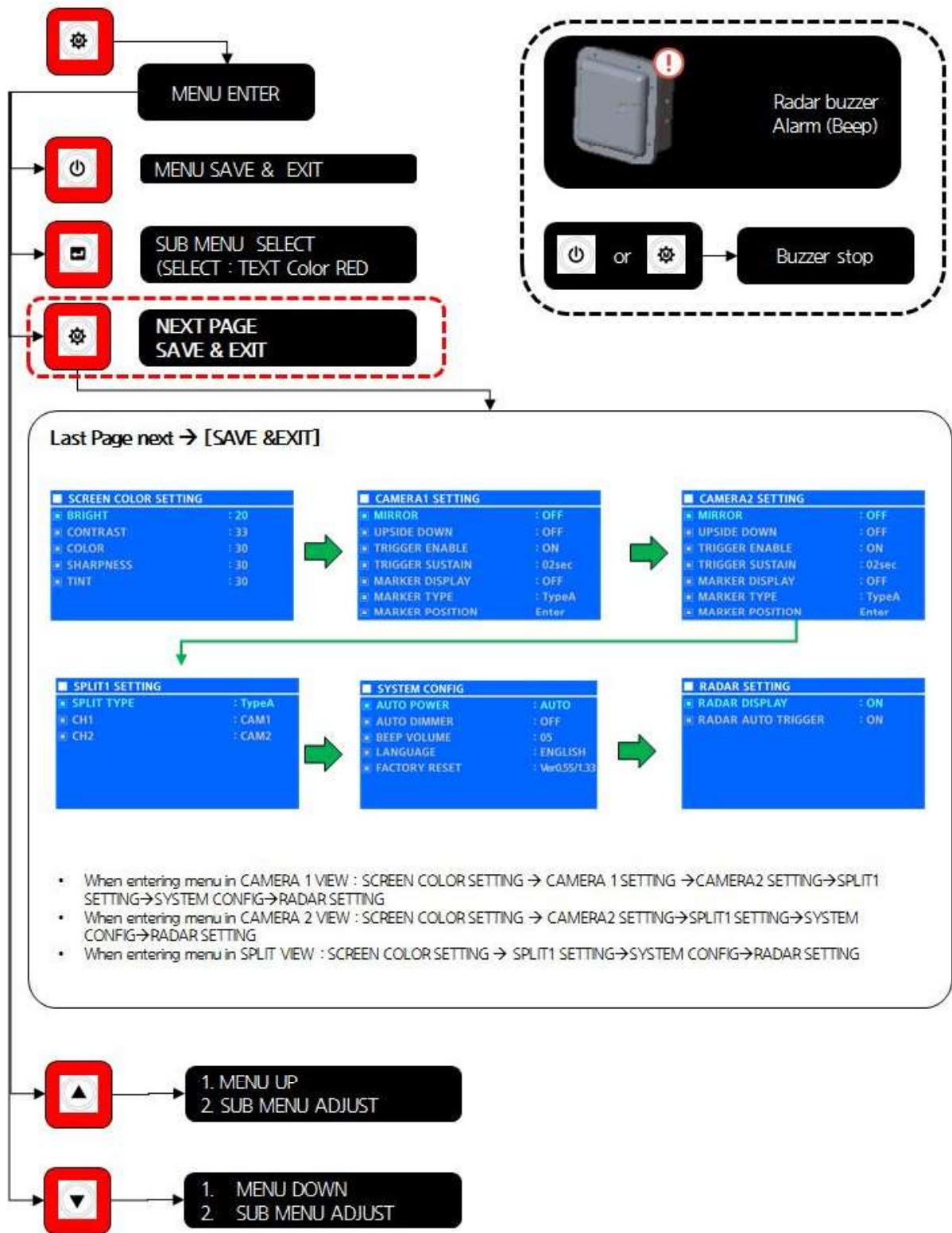

(10) Composition of menu screen

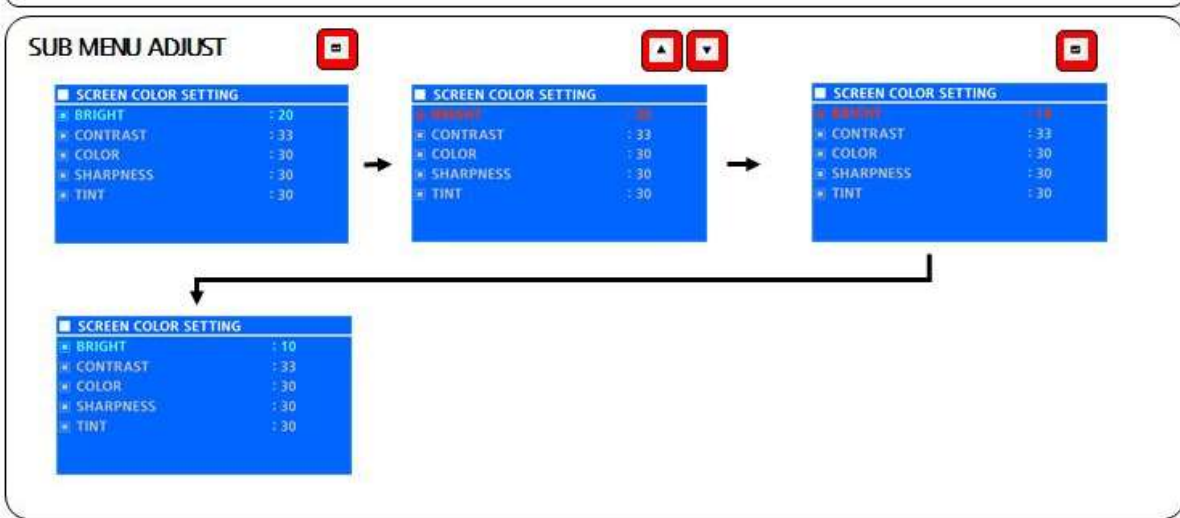
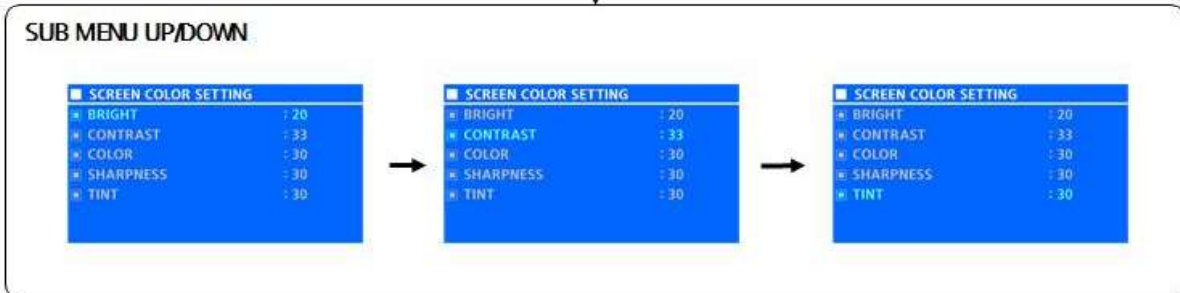
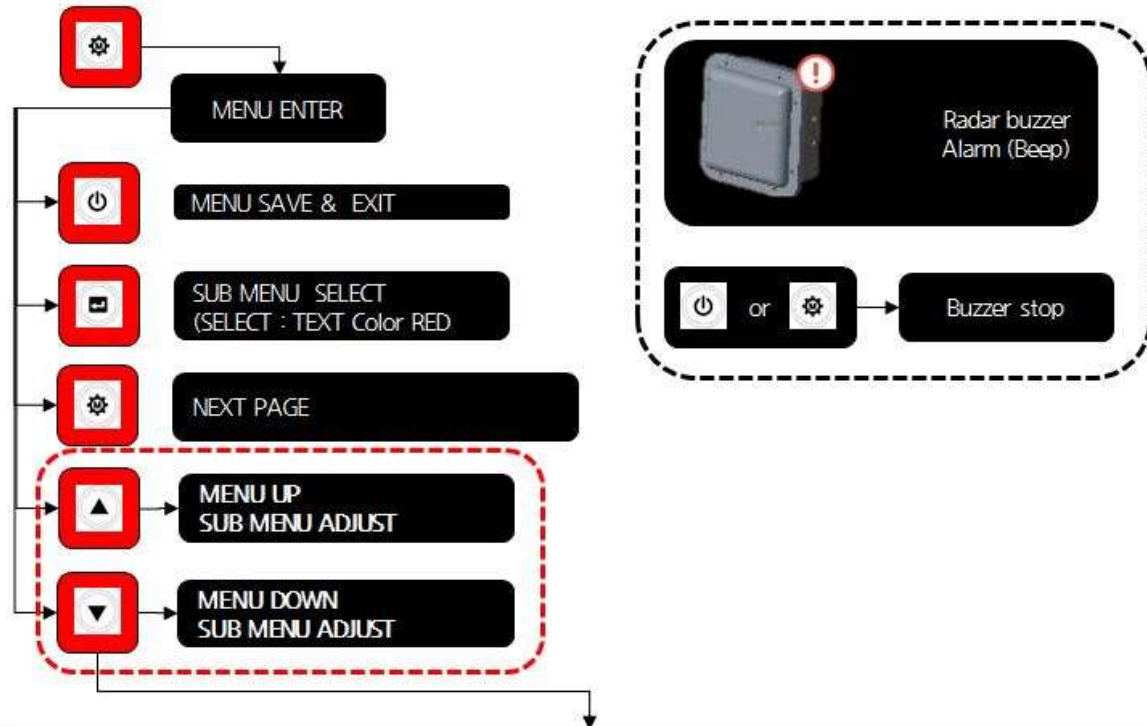

(11) Value adjustment



(12) When radar mounted, monitor display

ICON	Status
Not Display	Radar Off
	Radar On (Mode : Normal)
	Radar Error
	No detection for more than(30 min)

Distance Display	Status	Beep
	0~2 m Target	Alarm 200 millisecond
	2~4 m Target	Alarm 500 millisecond
	4~6 m Target	Alarm 500 millisecond
	6~8 m Target	Alarm 1000 millisecond
	8~10 m Target	Alarm 1000 millisecond
Not Display	Non Target	Not Beep

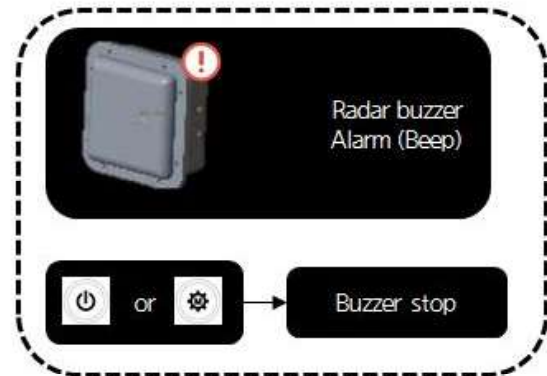

1. SUGGESTION FOR NEW MACHINE

- 1) It takes about 100 operation hours to enhance its designed performance.
- 2) Operate according to below three steps and avoid excessive operation for the initial 100 hours.

Service meter	Load
Until 10 hours	About 60%
Until 100 hours	About 80%
After 100 hours	100%

※ **Excessive operation may deteriorate the potential performance of machine and shorten lifetime of the machine.**

- 3) Be careful during the initial 100 hours operation.
 - (1) Check daily for the level and leakage of coolant, engine oil, hydraulic oil and fuel.
 - (2) Check regularly the lubrication and fill. Grease daily all lubrication points.
 - (3) Tighten bolts.
 - (4) Warm up the machine fully before operation.
 - (5) Check the gauges during operation.
 - (6) Check if the machine is operating normally during operation.
- 4) Replace followings after initial operation hours.

Checking items	Hours
Engine oil and filter	250
Fuel filter element	
Fuel pre-filter	
Transmission oil and filter	
Axle oil (front and rear)	
Hydraulic oil return filter	
Pilot line filter element	
Pressure filter element	

Avoid excessive operation for initial 100 hours

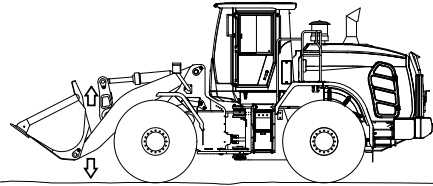

960A4OP01

2. CHECK BEFORE STARTING THE ENGINE

1) Make sure that the steering frame lock bar is stored in the unlocked position.

▲ The steering frame lock bar must be removed in order to steer the machine.

2) Look around the machine and under the machine to check for loose nut or bolts, collection of dirt, or leakage of oil, fuel or coolant and check the condition of the work equipment and hydraulic system. Check also loose wiring, and collection of dust at places which reach high temperature.

※ **Check the level of engine oil, coolant and hydraulic oil. Refer to the daily check on the chapter 6, Maintenance.**

3) Adjust seat to fit the contours of the operator's body for the pleasant operation.

4) Make sure that the machine is equipped with a lighting system that is adequate for the job conditions. Ensure that all lights are in proper working condition.

5) Adjust the rear view mirror.

6) Make sure that there are no personnel in the area before you start the engine. Make sure that there are no personnel in area before you move the machine. Make sure that there are no personnel on the machine, underneath the machine, or around the machine.

※ **Check that engine hood and all covers are to be closed and locked.**

▲ If a warning tag is attached to the starting switch or to the controls, do not start the engine. Also, do not move any controls.

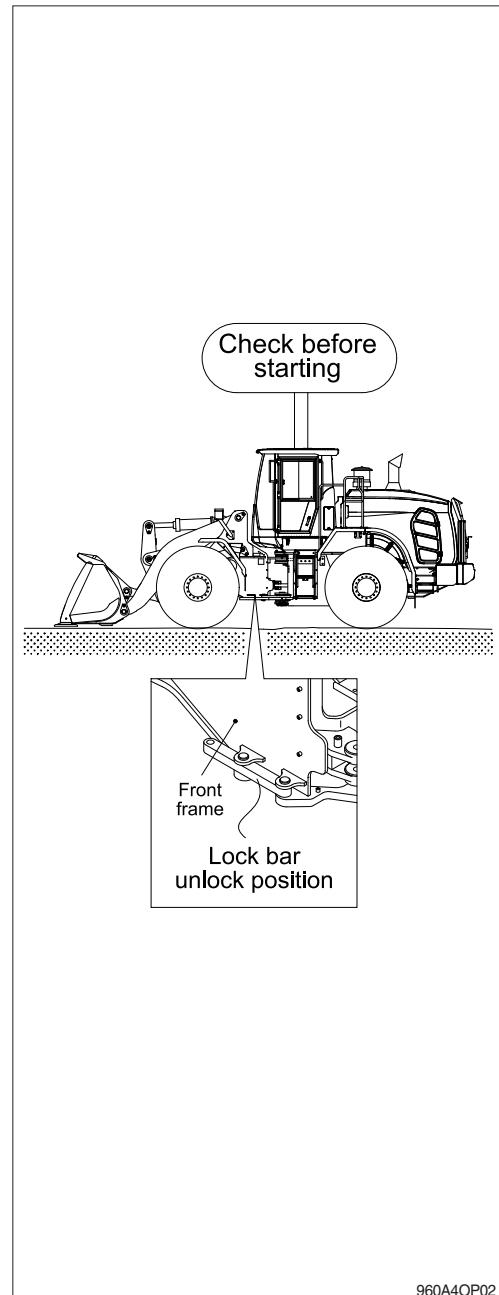

960A4OP02

3. STARTING AND STOPPING THE ENGINE

1) CHECK INDICATOR LIGHTS

- (1) Check if the parking brake switch is ON.
- (2) Check if the gear selector lever is in neutral position.
- (3) Check if the pilot cut off switch is OFF.
- (4) Turn the key to the ON position, and check followings.

· Cluster

- ① If all the lamps light ON after sounding buzzer for 3 seconds.
 - ※ If the lamps do not light or the buzzer is not sounded, check disconnection of wire.
- ② Only below lamps will light ON and all the other light will be turn OFF after 3 seconds.
 - Charging warning lamp (1)
 - Engine oil pressure warning lamp (2)
 - Brake fail warning lamp (3)

· Monitor

- ① The buzzer sounds for 3 seconds with HYUNDAI logo on monitor.
 - ② If the ESL mode is set to the enable, enter the password to start engine.
 - ③ If the password has failed 5 times, please wait 30 minutes before re-attempting to enter the password.
- ※ Refer to page 3-30 for ESL system setting.

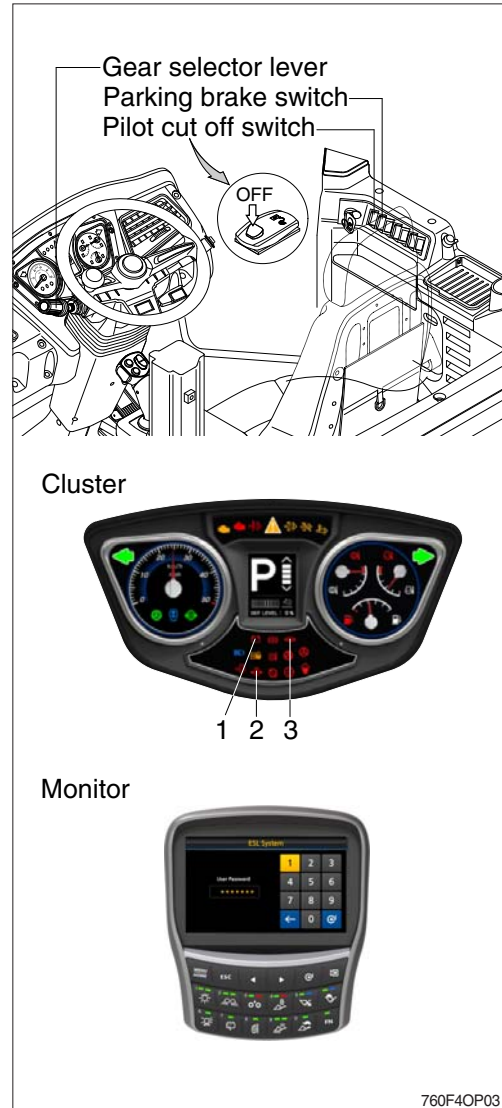

2) STARTING ENGINE IN NORMAL TEMPERATURE

※ **Sound the horn to warn the surroundings after checking if personnel or obstacles are in the area.**

(1) Check if the parking brake is locked (with the parking switch ON).

(2) Check if the gear selector lever is in the neutral position.

(3) Check if the pilot cut off switch is locked (with the switch OFF)

(4) Turn the starting switch to START position to start the engine.

※ **Do not crank the engine for more than 20 seconds. If the engine does not start, allow the starter to cool for about 2 minutes before attempting to start the engine again.**

(5) Release the starting switch instantly after the engine starts to avoid possible damage to the starting motor.

※ **Refer to the START PROCEDURE on the page 0-13.**

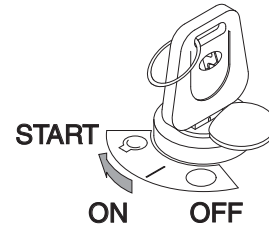

77074OP04

3) STARTING ENGINE IN A COLD WEATHER

- ※ Sound horn to warn surroundings after checking if there are obstacles in the area.
- ※ Replace the engine oil, coolant and fuel referring to recommended oils at page 6-9.
- ※ Fill the anti-freeze solution to the coolant as required.
- ※ If you turn ON the starting switch, the fuel warmer is automatically operated to heat the fuel by sensing the coolant temperature.

- (1) Check if the parking brake is locked (with the parking switch ON).
- (2) Check if the gear selector lever is in the neutral position.
- (3) Check if the pilot cut off switch is locked (with the switch OFF)
- (4) Turn the starting switch to ON position, and wait 1~2 minutes. More time may take according to ambient temperature.
- (5) Start the engine by turning the starting switch to START position after the preheater pilot lamp and fuel warmer pilot lamp OFF.

- ※ If the engine does not start, allow the starter to cool for about 2 minutes before attempting to start the engine again.

- (6) Release starting switch immediately after starting engine. The starting switch will automatically return to the ON position.

- ※ After engine started, the preheating function is actuated to reduce the white smoke.
- ※ Before the warming-up operation is completed, do not operate the equipment.
- ※ Operate machine at less than normal loads and at slow idle speed, right after engine warming-up.
- ※ Run the engine for 10~15 minutes at low idle when the ambient temperature is below -15°C.

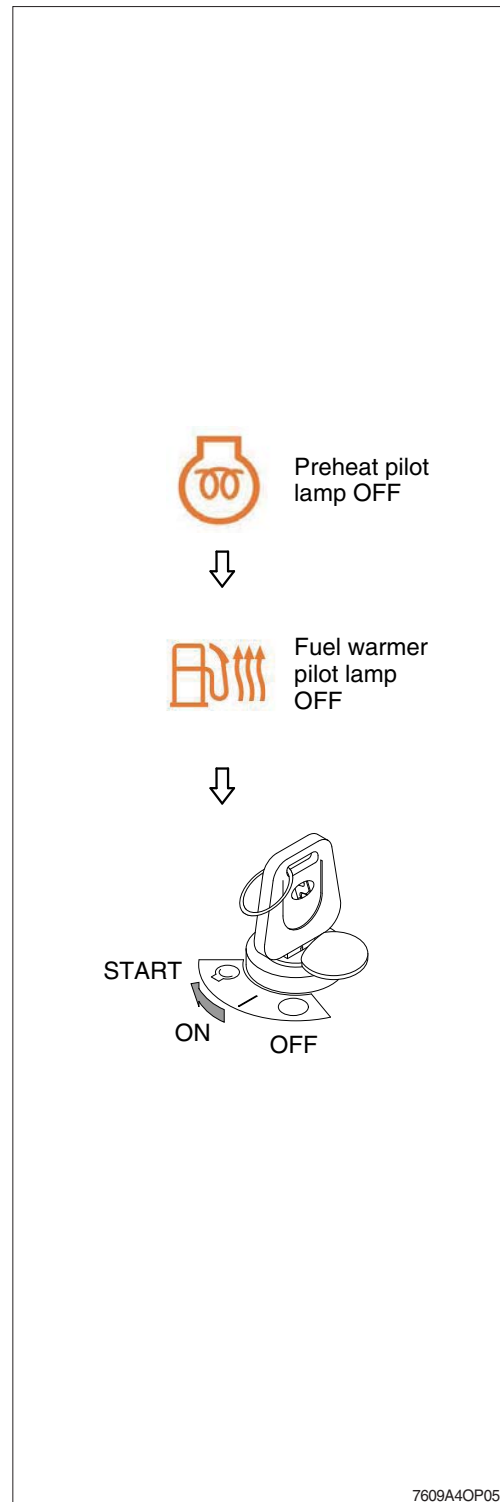

4) INSPECTION AFTER ENGINE START

Inspect and confirm the following after engine starts.

- (1) Is the level gauge of hydraulic oil tank in the normal level?
 - (2) Are there leakages of oil or water?
 - (3) Are all the warning lamps (1-19) OFF?
 - (4) Check the following after warming up operation.
 - ① Is the indicator of water temperature gauge (14) in the operating range?
 - ② Is the indicator of transmission oil temperature gauge (13) in the operating range?
 - ③ Is the engine sound and the color of exhaust gas normal?
 - ④ Are the sound and vibration normal?
- ※ **Do not increase engine speed quickly after starting, it can make damage engine or turbocharger.**
- ※ **If there are problems in the control panel, stop the engine immediately and correct problem as required.**

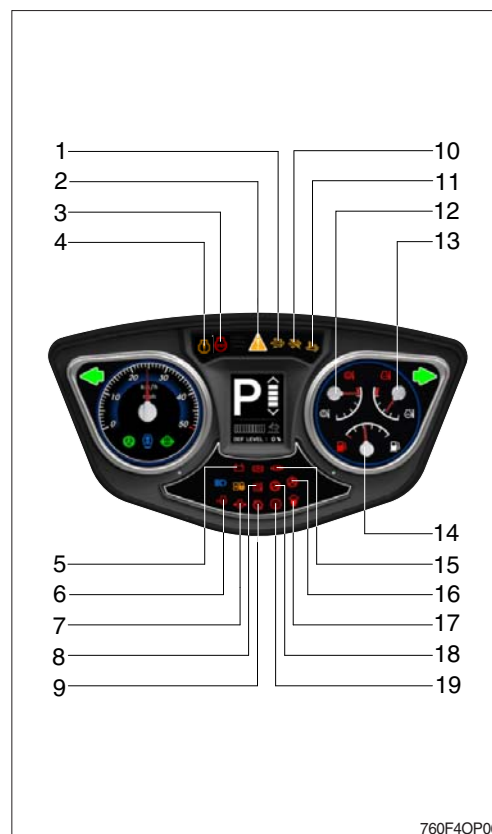

760F4OP06

5) TRANSMISSION COLD STARTING

- (1) At an oil temperature in the shifting circuit $< -12^{\circ}\text{C}$, the transmission must be warmed-up for some minutes.
- (2) This must be carried out in neutral with an increased engine speed.
- (3) Until this oil temperature is reached, the electronics remains in neutral, and the symbol of the cold start phase will be indicated on the display.
 - Indication on the display : * *
- (4) After the indication on the display is extinguished, the full driving program can be utilized out of NEUTRAL.

※ Transmission warning



760F4OP15

Symbol	Meaning	Remarks
LF, LR	Limp home gear	-
**	Oil temperature too low, no gear available	Warm up engine/transmission
WS	Warning sump temperature	Alternate between WS and actual gear / direction while driving, in neutral only displayed WS if no fault is detected ※ Cool down transmission
WT	Warning torque converter temperature	Alternate between WS and actual gear / direction while driving, in neutral only displayed WS if no fault is detected ※ Cool down transmission

6) TO STOP THE ENGINE

- ※ If the engine is abruptly stopped before it has cooled down, engine life may be greatly shortened. Consequently, do not abruptly stop the engine apart from an emergency.
- ※ In particular, if the engine has overheated, do not abruptly stop it but run it at medium speed to allow it to cool gradually, then stop it.

- (1) Place the gear selector lever in neutral.
- (2) Push the parking brake switch to the ON position.
- (3) Run the engine for five minutes at low idle with no load.
- (4) Return the key of starting switch to the OFF position.
- (5) Remove the key to prevent other people using the machine.
- (6) Push the pilot cut off switch to the OFF position.
- (7) Lock the cab door.

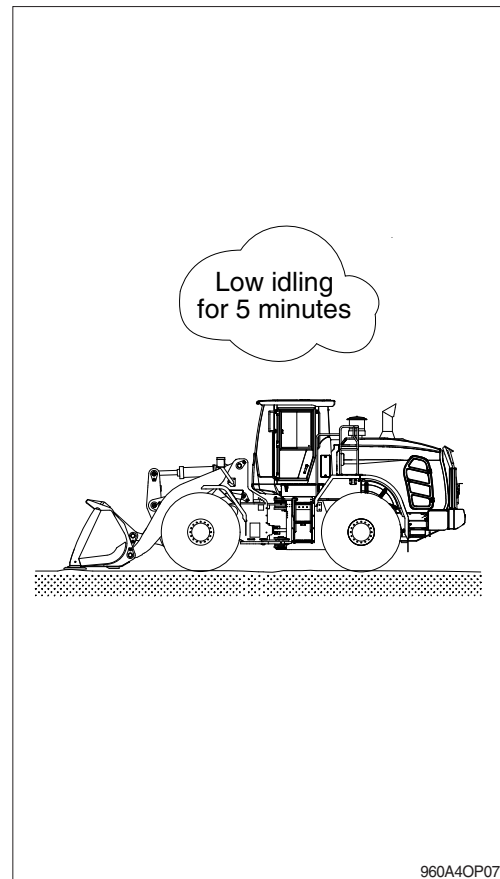

4. WARMING-UP OPERATION

※ The most suitable temperature for the hydraulic oil is about 50°C (112°F). It can cause serious trouble in the hydraulic system by sudden operation when the hydraulic oil temperature is below 25°C (77°F). The temperature must be raised to at least 25°C (77°F) before starting work.

- 1) Run the engine at low idling for 5 minutes.
- 2) Speed up the idling and run the engine at mid-range speed.
- 3) Push the pilot cut off switch to the ON position.
- 4) Lift the boom slightly and extend the bucket cylinder to the stroke end to relieve hydraulic pressure.
※ Do not leave hydraulic pressure relieved for more than 30 seconds.
- 5) Shorten the bucket cylinder to the stroke end to relieve hydraulic pressure.
※ Do not leave hydraulic pressure relieved for more than 30 seconds.
- 6) Repeat the procedure 4) - 5) several times until warm-up operation is completed.

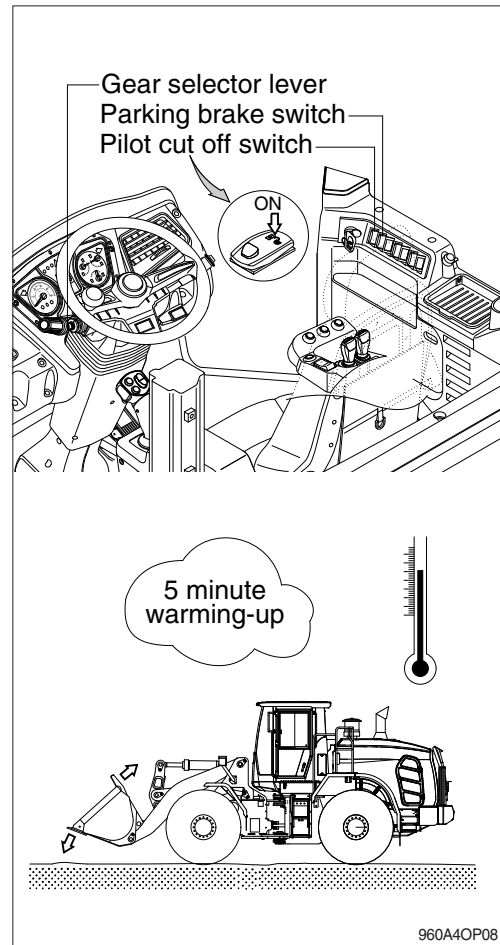

5. OPERATION OF THE WORKING DEVICE

※ **Confirm the operation of control lever and working device.**

- 1) Control lever operates the boom and the bucket.
- 2) When you release the control lever, control lever returns to neutral position automatically.
- 3) When the control lever operates to the position of boom float, boom kick out and bucket leveler ; these function is completed, then the control lever returns to the neutral position.

※ **Control lever**



Boom lower (1)

Push the control lever forward in order to lower the boom.



Boom raise (2)

Pull the control lever backward in order to raise the boom.



Bucket roll back (3)

Move the control lever toward the left in order to tilt the bucket backward.



Bucket dump (4)

Move the control lever toward the right in order to dump a load from the bucket.



Boom float (5)

Push the control lever forward into the detent.

The boom will lower to the ground. The boom will float along the contour of the ground.

RCV lever

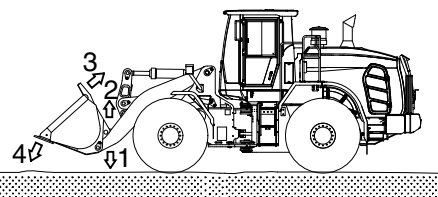
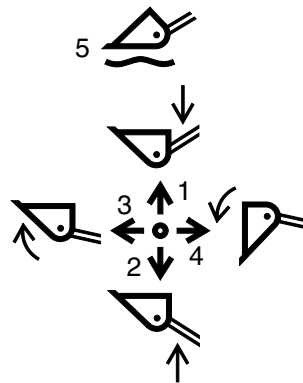
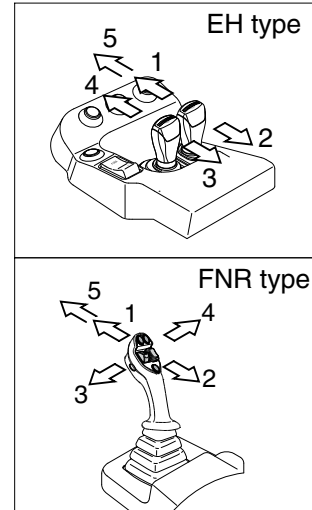

960A4OP09

6. TRAVELING OF THE MACHINE

1) BASIC OPERATION

※ Secure the engine hood in the fully closed position prior to traveling the machine.

(1) Traveling posture

Lift the boom so that the bucket is placed 40-50cm above the ground.

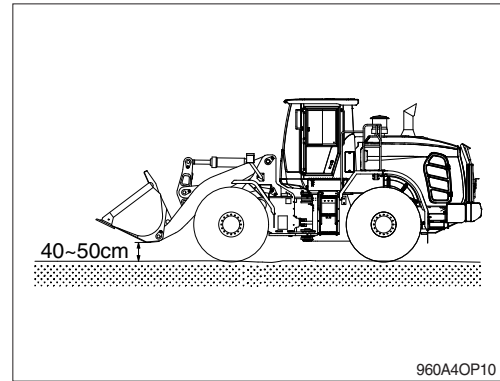

(2) Traveling operation

When warm-up operation is completed after the engine is started, move the machine according to the following procedure.

- ① Push the pilot cut off switch to the ON position.
- ② Release the parking brake.
- ③ Put the gear selector lever in the 1st stage of forward or backward direction and press gently the accelerator pedal to move the machine.

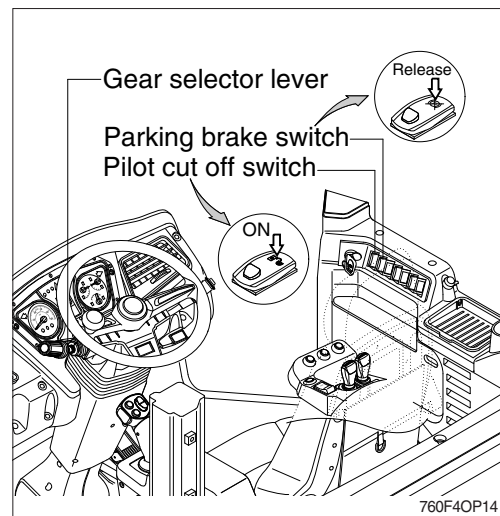

(3) Changing direction and speed

- ① The gear selector is designed for the mounting on the left side of the steering column.
- ② The positions (speeds) 1 to 4 are selected by a rotary motion, the driving direction Forward (F)-Neutral (N)-Reverse (R) by tilting the gear selector lever.
- ③ A neutral lock is installed as protection against inadvertent drive off.
 - Position N - Gear selector lever blocked in this position
 - Position D - Driving
- ④ When doing digging or dumping work, run the machine in the 1st or 2nd speed.

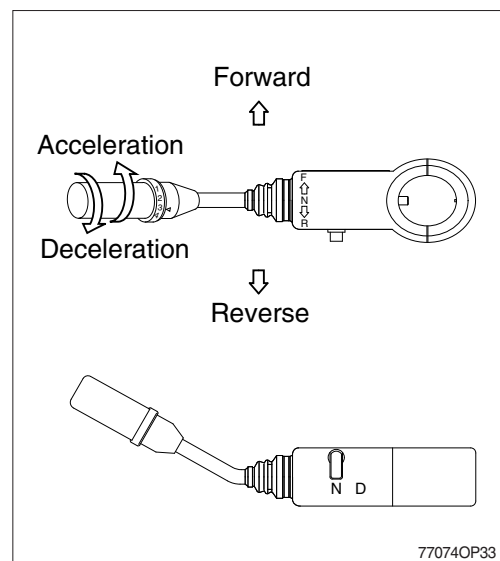

- ※ When traveling at high speed, do not abruptly decelerate by using the transmission lever, to slow down instead press the brake pedal.
- ※ When changing direction, check beforehand there is no obstacle in the direction you will be headed.
- ※ Avoid changing direction at high speed.

(4) Turning the machine

- ① Turn the machine by moving the steering wheel into the desired direction.
 - ② You can turn the machine to the left or right by 40 degree.
- ※ Do not turn the machine abruptly when traveling at high speed and avoid turn on a slope.
- ▲ Steering does not function with engine OFF.

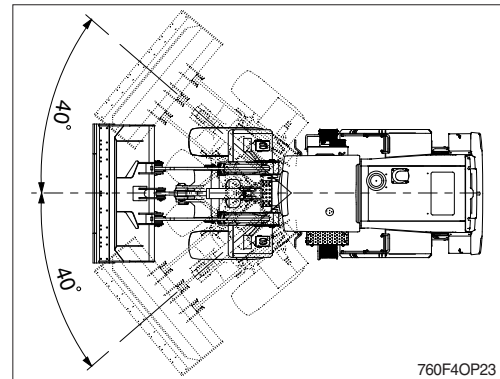

(5) Precautions when driving

- ① If the monitor warning lamp lights up, put the gear selector lever in the neutral position and stop the machine. Stop the engine after running it at low idling. Then resolve any problems regarding operation of the machine.
- ② When operating the machine, if the load is lightened rapidly, the speed of the machine will increase. So, be careful.
- ③ When the machine travels on uneven ground, keep the machine traveling at low speed.

(6) Stopping the machine

- ① Press the brake pedal to stop the machine.
- ② Put the gear selector lever in the neutral position.
- ③ Push the parking brake switch to the ON position.

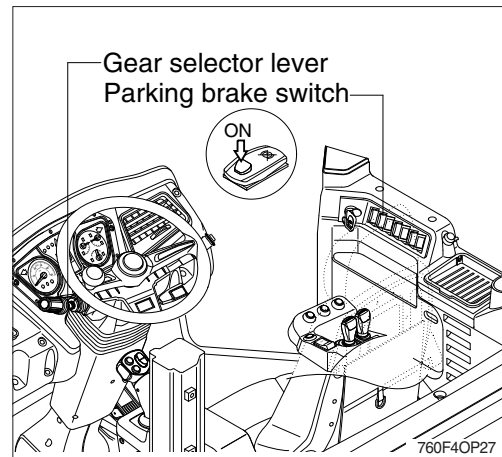

- ④ Lower the bucket to the ground.

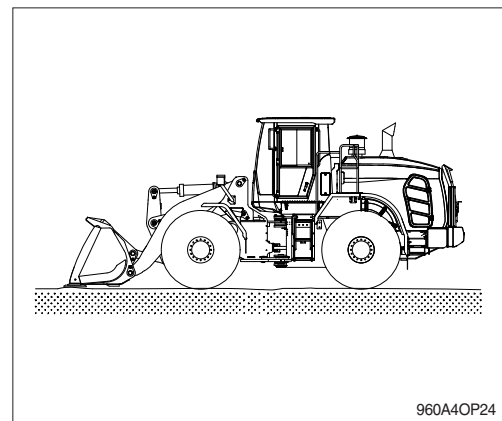

- ⑤ Push the pilot cut off switch to the OFF position.
- ※ **When parking on a slope, block the tires.**

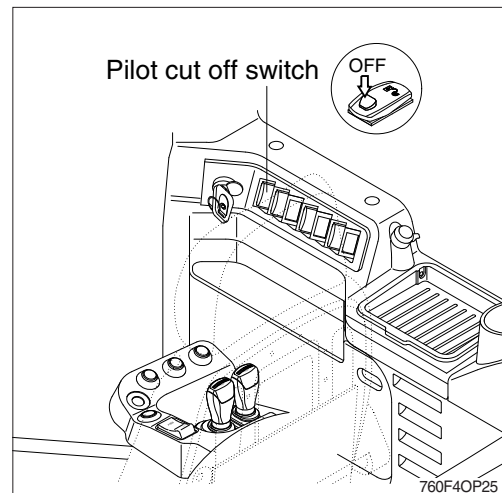

(7) Stopping engine

※ If the engine is abruptly stopped before it has cooled down, its service life may be shortened. Avoid sudden stop except an emergency.

※ When the engine is overheated, do not stop immediately. Run the engine at a mid range speed to allow it to cool down, then stop it.

- ① Check if the parking brake switch is ON.
- ② Check if the gear selector lever is in the neutral position.
- ③ Check if the pilot cut off switch is OFF.
- ④ Run the engine at low speed without operating the equipment for about 5 minutes.
Turn the starting key to the OFF position and remove the key.

(8) Checks after the engine stopped

- ① Check the leakage of oil and water, the work equipment and the exterior of the machine.
- ② Refill the fuel tank.
- ③ Remove any debris inside of the engine room and attached to the machine.

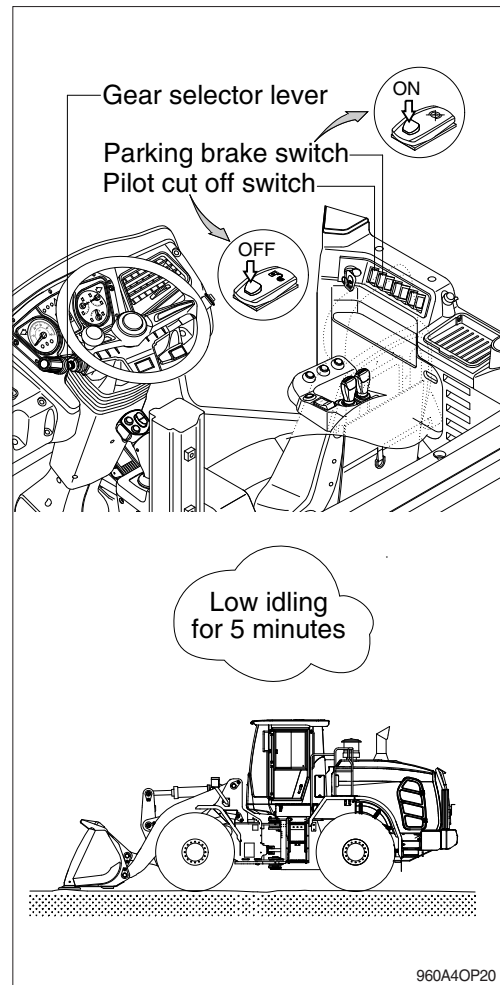

2) TRAVELING ON A SLOPE

- (1) Never travel down a slope in neutral.
 - (2) Lower the bucket 20-30 cm (1 ft) to the ground so that it can be used as a brake in an emergency.
 - (3) If the machine starts to slide or loses stability, lower the bucket immediately and brake the machine.
 - (4) When parking on a slope, use the bucket as a brake and place blocks behind the tires to prevent sliding.
- ※ **Machine cannot travel effectively on a slope when the oil temperature is low. Do the warming-up operation when it is going to travel on a slope.**
 - ※ **Be careful when working on slopes. It may cause the machine to lose its balance and turn over.**

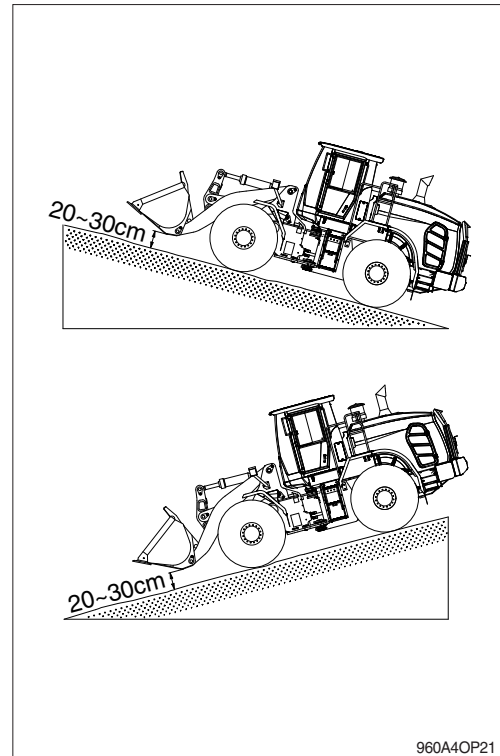

960A4OP21

7. EFFICIENT WORKING METHOD

1) GENERAL

- (1) Lift the bucket about 40-50 cm (2 ft) above the ground to ensure safety and to gain a good range of view.
- (2) Clear the jobsite and level the ground.
- (3) Be careful that excessive force is not applied to the bucket.
- (4) When handling hard materials, use bucket teeth or bolt on cutting edge.
- (5) When doing dumping work, put the control lever in the DUMP position, then return it to a former state. Repeat this procedure until the work is finished.
- (6) Position the machine with its back against the wind so that dust does not get into the engine.
- (7) Check if the proper bucket is used for the work.
If the capacity of the bucket exceeds that of the machine, the machine's service life may be shortened.

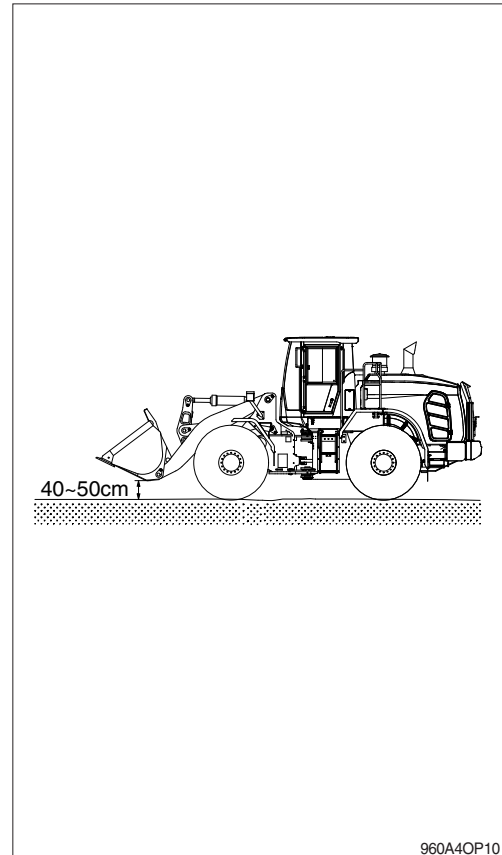

2) EXCAVATION WORK

(1) Shovel work

As the machine loads on the bucket with traveling, tires may start to slip because of heavy load. Then lift the bucket slightly to reduce load.

- ① Keep the bucket shovel parallel to the ground (If the bucket is pushed in a non-horizontal position, power may be reduced, and the bucket cannot dig deeply into the heap of soil).

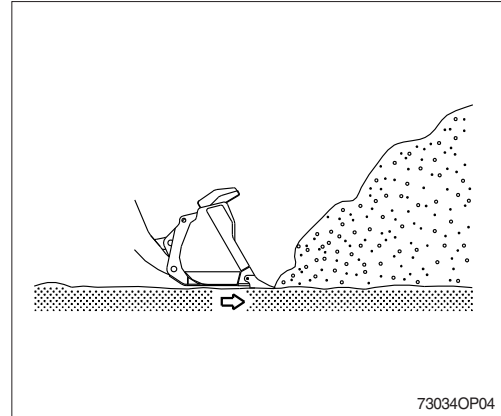

- ② When the bucket is sufficiently deep into the pile, advance the machine with the control lever pulled down. And by placing the control lever in the bucket roll-back position, fill the bucket with soil.

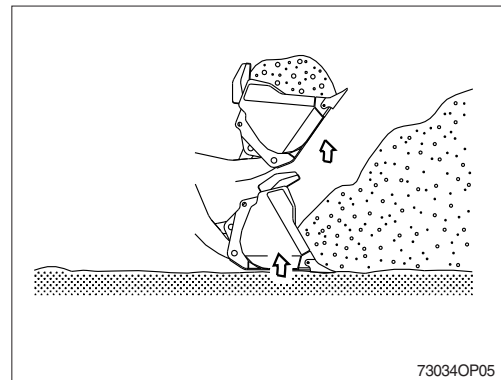

- ③ When it is difficult to dig into the soil, move the bucket control lever forward and backward to move the bucket teeth up and down.

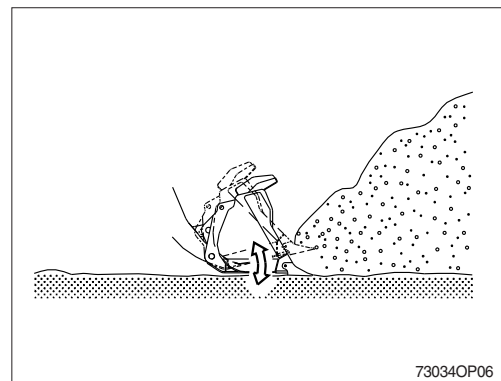

- ※ If the machine operates with its front tires lifted, its driving force will deteriorate and excessive force will be applied to the rear tires. Avoid operating in that posture.

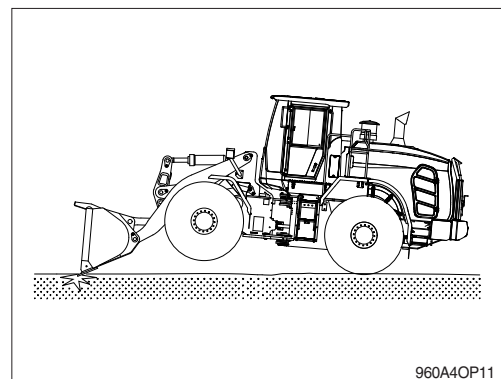

(2) Excavation on level ground

Advance the machine with the bucket lowered slightly and make sure that the bucket is evenly loaded on both sides.

- ① Lower the bucket edge slightly.

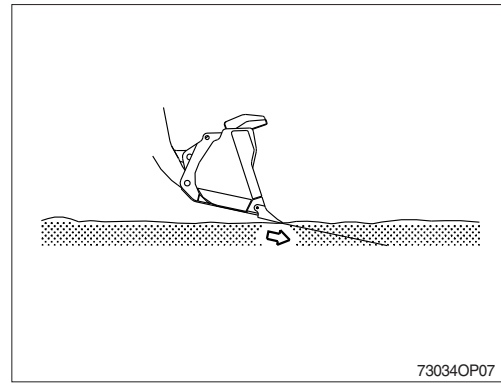

- ② Advance the machine and lift the bucket using the bucket control lever to dig out the soil.

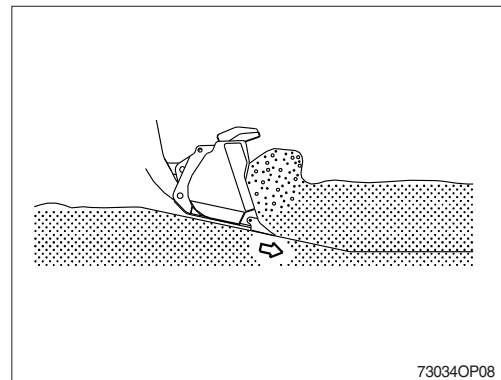

- ③ Advance the machine while controlling the depth of digging with the control lever.
 - ※ Do not press the bucket heavily into the ground. It may damage its driving force.
 - ※ Use the bucket suitable to the working condition.
 - ※ When excavating, prevent the excavation force from applying only one side of the bucket.

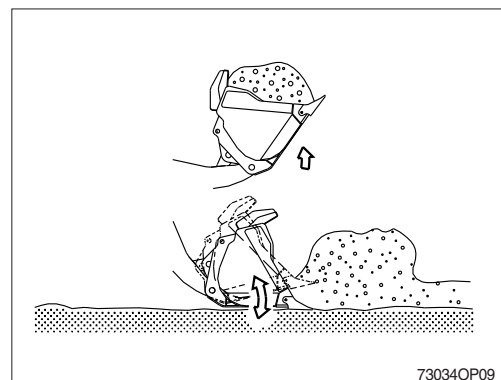

3) LEVELING

- (1) Load the bucket with soil and dump gradually the soil while driving backward.
- (2) After dumping the soil, move backward with the bucket lowered to the ground to level the ground.
- (3) Load the bucket with soil and place the bucket in the horizontal position. Then put the control lever in the BOOM FLOAT position and move backward.

※ **Make sure that the machine moves always backward when doing leveling work.**

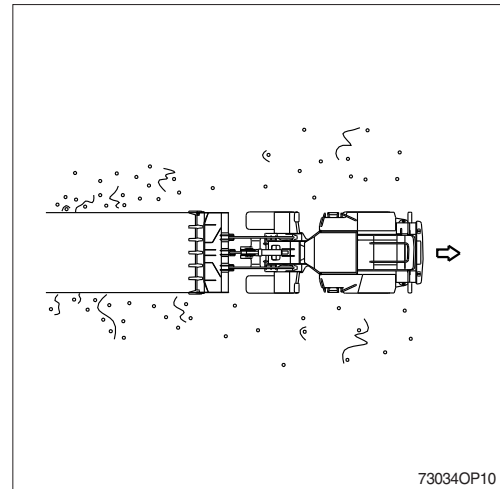

4) TRANSPORTATION

- ※ **Make sure that the traveling path is always cleared.**
- ※ **When transporting material, lift the bucket 40-50 cm above the ground.**

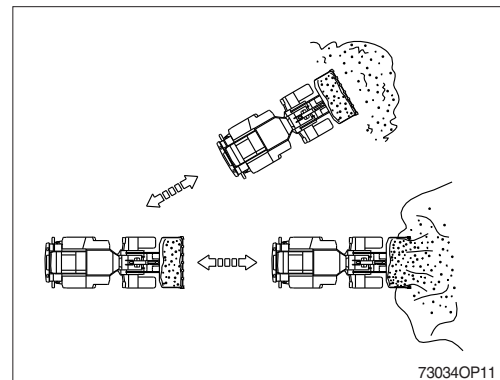

5) COMPACTION

When operating, keep the bottom of the bucket horizontal to the ground.

- ※ **Do not work with the bucket set in the DUMP position.**

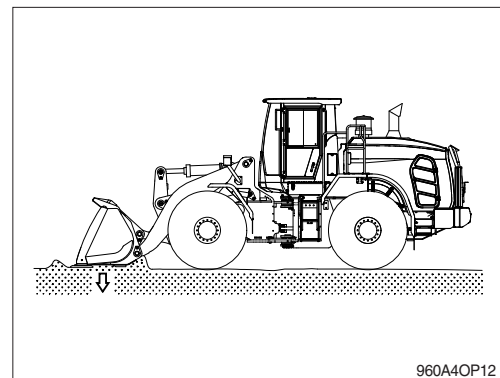

6) LOADING

Maximum efficiency can be attained by carrying out work in such a way that the swinging angle and the traveling distance are kept as small and short as possible in accordance with the terrain.

(1) I method

- ① After digging out the soil, move backward and position the dump truck between the heap of soil and the machine to load the soil into the truck.
 - ② This is the fastest and most efficient way to load material.
- ※ **The ground of the jobsite should be always level and do not swing or step on a brake pedal abruptly with the boom raised.**

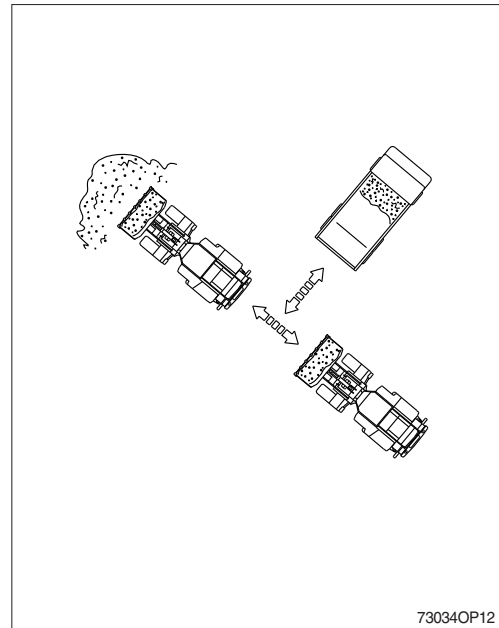

(2) V method

- ① Park the truck at an angle of 60 degrees toward the machine. After digging out, drive backward and position the machine at a right angle with the truck and load the truck with the soil.
- ② Position the machine so that the soil can be dumped in the center of the truck.
If the length of the truck is more than double the width of the bucket, perform the dumping work from forward to backward.
- ③ Move the control lever to the right and dump the bucket.
- ④ Shake the bucket to throw off the soil stuck inside. Move the bucket control lever to the left and right and attach the bucket to the stopper.

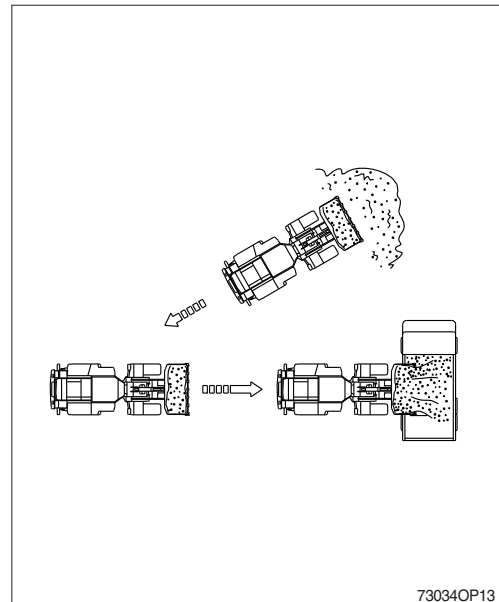

- ⑤ Shake the bucket before setting it to the DUMP position so that loaded materials are evenly distributed inside the bucket. This will prevent materials from slipping back when the bucket is placed in the DUMP position.

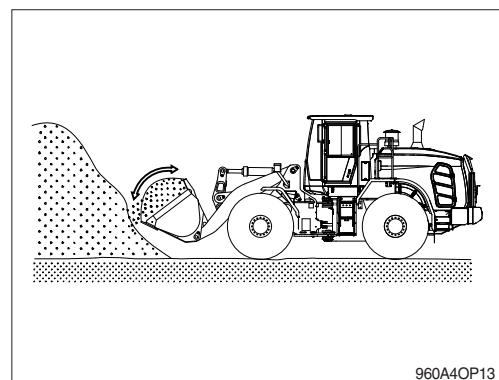

7) PRECAUTIONS DURING OPERATION

(1) Permissible water level

- ① Do not work in water or damp ground deeper than the permissible depth (Up to lower part of the axle housing).
- ② After the work is completed, grease parts which has been immersed in water.

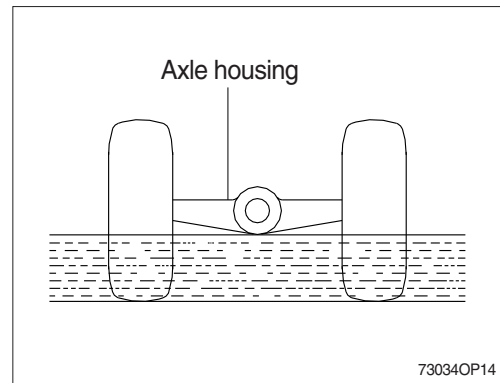

(2) When the brake does not operate

- ① If the machine does not stop even though the brake pedal is applied, use the parking brake.
- ※ After using the parking brake as an emergency brake, ask Hyundai dealer to check complete brake system.

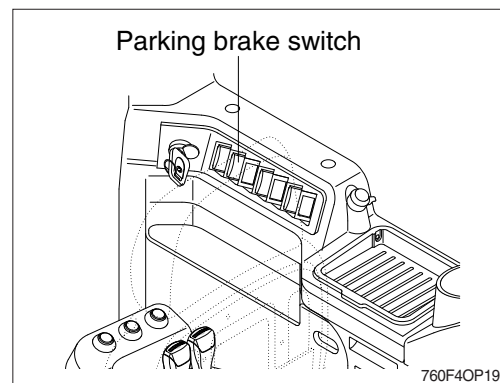

(3) Precautions when driving on a slope

- ① When turn on a slope, lower the work equipment to lower its center of gravity. Avoid turn on a slope if possible.

② When traveling down a slope

- a. If the main brake is used too often when traveling down a slope, it may be overheated and damaged. So put the transmission lever in the low speed position and use the engine as a brake.
- b. If there is a mismatch of speed, torque converter oil temperature may be overheated. Set the speed in 1st speed position to allow the temperature to drop.
- c. When the gauge does not move into the green range at the 1st speed, stop the machine and put it in neutral. Run the engine at a mid range speed until the gauge moves into the green range.

③ When the engine stops

If the engine stops on a slope, press the parking brake switch immediately and lower the work equipment to stop the machine.

(4) Precautions when traveling

Do not travel a long distance at high speed. It may overheat tires and cause premature damage. If it is necessary to travel a long distance at high speed, observe the following.

- ① Comply with the regulations concerning this machine to ensure safety.
- ② Do the pre-inspection before starting off.
- ③ As the optimum air pressure of tire and optimum driving speed is different according to the kinds of tires and road conditions, consult Hyundai dealer or tire distributor.
- ④ Check the air pressure of tire before driving.
- ⑤ After 1 hour driving, stop for 30 minutes to check any abnormality of tires and other parts, and level of oil and coolant.
- ⑥ Travel with the bucket empty.

8. ADJUSTMENT OF THE WORK EQUIPMENT

The bucket can be adjusted to a height desired by using the boom kick-out device.

- ▲ Park the machine on level ground and block the tires to prevent sudden movement of the machine.
- ▲ Press the parking brake switch.
- ▲ Fix the front and rear frames by using the safety lock bar.
- ▲ Do not work underneath the work equipment.

1) ADJUSTMENT OF THE BOOM KICKOUT AND BUCKET LEVELER

(1) Lift kickout position

To set the lift kickout, raise the bucket to the desired position above the midway point. Then push icon ( , A) for 2~3 seconds. The boom will return to the programmed position when the raise detent is activated and the boom is below the kickout position.

(2) Lower kickout position

To set the lower kickout, lower the bucket to the desired position below the midway point. Then push icon ( , A) for 2~3 seconds. The boom will return to the programmed position when the float detent is activated and the boom is at least a foot above the kickout position.

(3) Bucket leveler position

To set the bucket leveler, roll back the bucket to the desired position. Then push icon ( , B) for 2~3 seconds. The bucket will return to the programmed position when the roll back detent is activated and the bucket is below the leveler position.

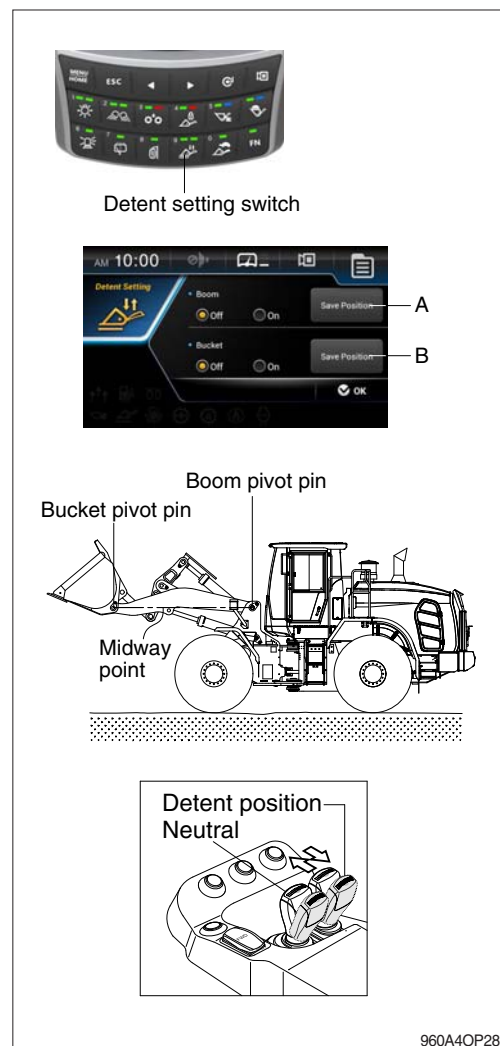

9. OPERATION IN THE SPECIAL WORK SITES

1) OPERATION THE MACHINE A COLD WEATHER

- (1) Use proper engine oil and fuel for the weather.
- (2) Fill the required amount of antifreeze in the coolant.
- (3) Refer to the starting engine in cold weather.
Start the engine and extend the warming-up operation.
- (4) Be sure to open the heater cock when using the heater.
- (5) Always keep the battery completely charged.
※ **Discharged batteries will freeze more easily than fully charged.**
- (6) Clean the machine and park on the wood plates.

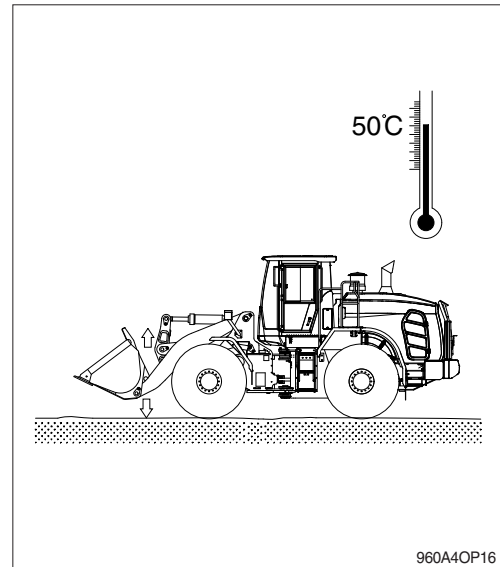

2) OPERATION IN SANDY OR DUSTY WORK SITES

- (1) Inspect air cleaner element frequently. Clean or replace element more frequently, if warning lamp comes ON and buzzer sounds simultaneously, regardless of inspection period.
- (2) Inspect radiator frequently, and keep cooling fins clean.
- (3) Prevent sand or dust from getting into fuel tank and hydraulic tank during refilling.
- (4) Prevent sand or dust from penetrating into hydraulic circuit by tightly closing breather cap of hydraulic oil tank. Replace hydraulic oil filter frequently.
- (5) Keep all lubricated part, such as pins and bushings, clean at all times.
- (6) If the air conditioner and heater filters clogged, the heating or cooling capacity will drop. Clean or replace the filters more frequently.

3) SEA SHORE OPERATION

- (1) Prevent ingress of salt by securely tightening plugs, cocks and bolts of each part.
- (2) Wash machine after operation to remove salt residue.
Pay special attention to electrical parts and hydraulic cylinders to prevent corrosion.
- (3) Inspection and lubrication must be carried out more frequently.
Supply sufficient grease to replace all old grease in bearings which have been submerged in water for a long time.

10. STORAGE

Maintain the machine taking care of following to prevent the deterioration of machine when storing the machine for a long time, over 1 month.

1) CLEANING THE MACHINE

- Clean the machine.
- Grease each lubrication part.

2) LUBRICATION POSITION OF EACH PART

Change all oil.

- ※ **Be particularly careful when you reuse the machine.**

As oil can be diluted during storage.

Apply an anticorrosive lubricant on the exposed part of piston rod of cylinder and in places where the machine rusts easily.

3) MASTER SWITCH

Turn OFF the master switch and store the machine.

- 4) Be sure to mix anticorrosive antifreezing solution in the radiator.

5) PREVENTION OF DUST AND MOISTURE

Keep machine dry. Store the machine setting wood on the ground.

- ※ **Cover exposed part of piston rod of cylinder.**
- ※ **Lower the bucket to the ground and set a support under tires.**

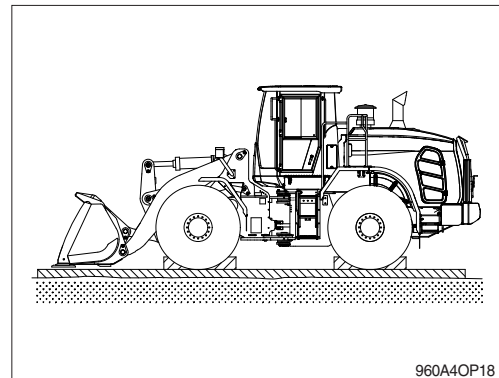
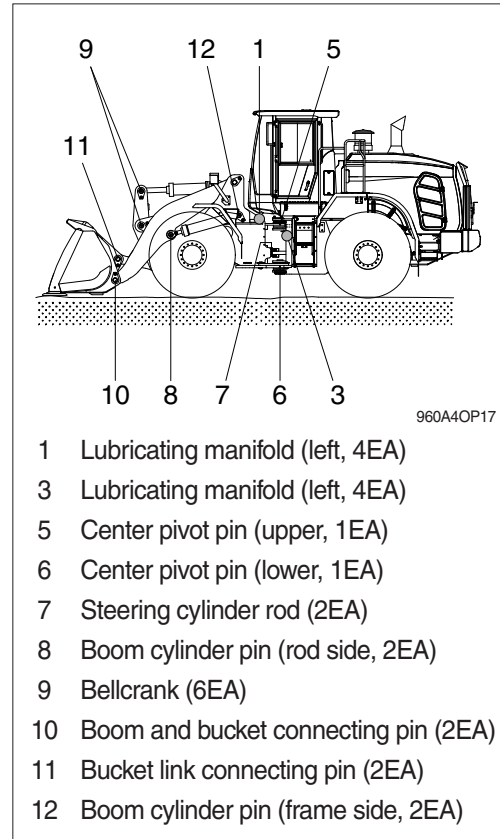

6) DURING STORAGE

Start engine and move the machine and working equipment once a month and apply lubrication to each part.

- ※ Check the level of engine oil and coolant and fill if required when starting engine.
- ※ Clean the anticorrosive on the piston rod of cylinder.
- ※ Operate the machine such as traveling, turning, and work equipment operation to make sure enough lubrication of all functional components.

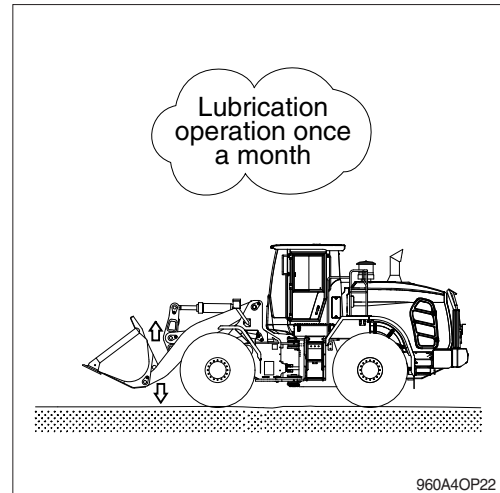

※ BATTERY

- ① Once a month, start the engine for 15 minutes (or use a charger) to charge the battery.
- ② Every 2 months, check the battery voltage and keep battery voltage over 25.08V.
- ③ If the machine stock period is over 6 months, disconnect the battery negative (-) terminal.

11. EXHAUST SYSTEM CLEANING

- ※ Exhaust system cleaning events for the catalyst system will happen automatically under normal engine conditions and are controlled by the ECM as long as the exhaust system cleaning Inhibit switch is not engaged. During automatic exhaust system cleaning, any warning lamps or fault codes will not occur so the operator can not notice the cleaning is being performed.
- ※ If automatic exhaust system cleaning does not occur, the exhaust system cleaning lamp will illuminate, indicating to the operator that they will need to perform a manual exhaust system cleaning.
- ※ The HEST Lamp will be illuminated during the entire exhaust system cleaning.
- ※ While the exhaust system cleaning occurs, fuel consumption will be increased 20~30% more than usual due to post fuel injection to the exhaust system to reach enough exhaust temperature for regeneration.
- ※ The operator can check logs of exhaust system cleaning events on an engine diagnostic tool (INSITE).
- ▲ Tampering, modifying, or removing any component of the exhaust system is strictly prohibited in law.
- ▲ Exhaust system cleaning generates hot exhaust and causes hot exhaust system components.
- ▲ Exhaust system components get very hot and can cause severe burns. Risk for fire.
- ▲ Do not perform exhaust system cleaning in a flammable environment.

(1) Exhaust system cleaning warning lamp

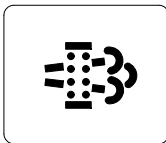

2609A3CD19

This warning lamp will light ON or blink when the exhaust system cleaning is needed or activated.

- ※ Refer to page 3-8 for details.
- ※ The machine must be in a fireproof area during the entire exhaust system cleaning process.

(2) Exhaust system cleaning inhibit warning lamp



2609A3CD20

This warning lamp will light ON when the exhaust system cleaning switch is pushed inhibit position.

- ※ Refer to page 3-8 for details.

(3) HEST (high exhaust system temperature) warning lamp

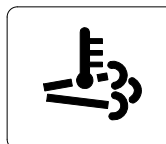

2609A3CD21

This warning lamp will light ON when the exhaust temperatures are high due to exhaust system cleaning.

- ※ Refer to page 3-9 for details.

(4) Exhaust system cleaning switch



2609A4OP16

This switch is used to select the exhaust system cleaning.

- ※ If system conditions are not met, the exhaust system cleaning will not start.
- ※ Refer to page 3-46 for details.
- ※ Manual exhaust system cleaning : refer to page 3-9 for details.

12. OPEN THE ENGINE HOOD

- 1) The engine hood open toggle switch controls the engine hood. It is located in tool box on the left side of rear frame.
- 2) Open the access door.

※ **The engine hood may not be operated when the machine's engine is running. Risk of machine damage.**

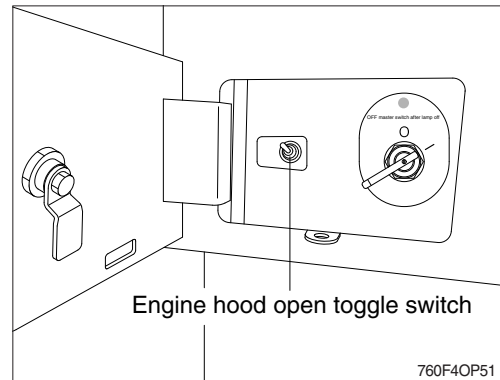

- 3) Move the toggle switch pull and up (①) in order to open the engine hood.
- 4) Move the toggle switch pull and down (②) in order to close the engine hood.
- 5) Hold the toggle switch until the engine hood is fully opened or closed. Release the switch. The switch will return to the middle position.

- ※ **When opening the engine hood, the counterweight shelf must be clear of dirt, debris or objects. The rear of the engine hood can be damaged if the engine hood is opened with objects on the shelf.**
- ※ **Ensure that there are no personnel or equipment around the hood during operation.**
- ※ **Secure the engine hood in the fully raised position before performing any maintenance work in the engine room.**

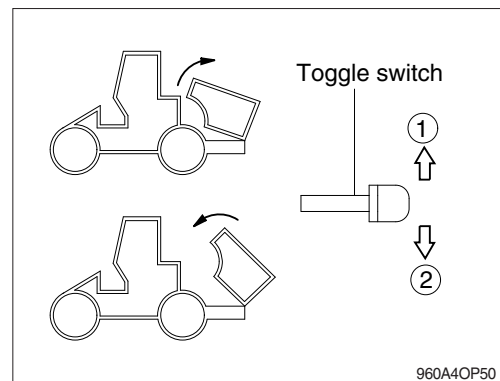

- 6) When hood is opened, cover the air intake and the aftertreatment device outlet to prevent any water entry.

※ **Secure the hood in the fully close position or the fully open position prior to starting the engine. Operating the machine with the hood partially open can cause the exhaust to damage hood components. Do not allow water to enter the aftertreatment device.**

Water will damage the aftertreatment device.

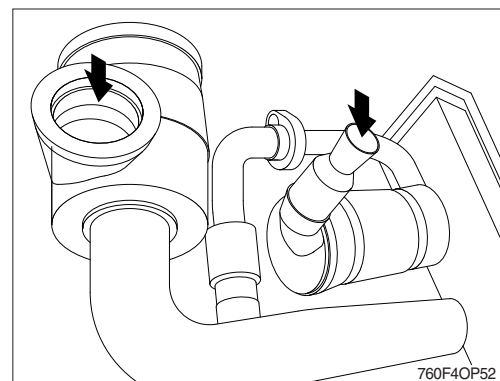

7) If further access is needed, either side cover can be opened. The levers are positioned in the both side of the engine room. Hold the side cover in place, while unlatching the side cover. Lower the side cover to rest on the tire. The side cover can remain in the open position resting on the tire. For better access the side cover can be removed. Push the side cover forward along the hinge to remove the side cover fully.

⚠ Avoid contact with hot surfaces. Exhaust piping and engine components become hot during engine operation and cool slowly after engine shut down. Any contact with hot surfaces can cause severe burns.

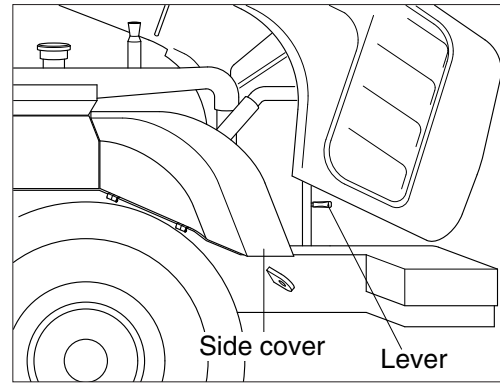

760F4OP53

8) EMERGENCY FIRE HOLES

If the engine hood cannot be opened in case of the fire, it is possible to fight the fire manually through two holes on the screen.

Holes for manual firefighting can be accessed by opening the inlet covers on the right and left side.

Firefighting can take place using the holes on the screen, which provide access to the engine compartment with, e.g., handheld fire extinguisher.

⚠ The extinguishing agent contains glycol which may cause injuries in case of contact. Avoid contact. In case of contact with the eyes, rinse with water. In case of skin contact, wash with soap and rinse with water. Always contact a doctor after contact with the extinguishing agent.

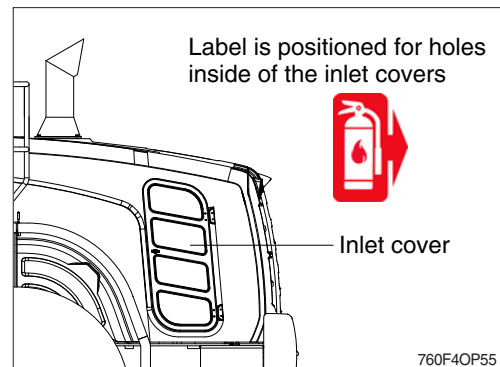

760F4OP55

9) MANUAL OPERATION OF ENGINE HOOD

The engine hood can be operated manually.

(1) Open the RH vent cover.

(2) Remove the socket (Keep the socket to reuse) and turn the hand crank (6mm hexagon wrench) to open engine hood.

※ When the actuator is operated as a hand crank, it must be operated by hand or carefully by tool otherwise there is a risk of overloading and damage of actuator.

※ The master switch has to turn OFF during manual operation.

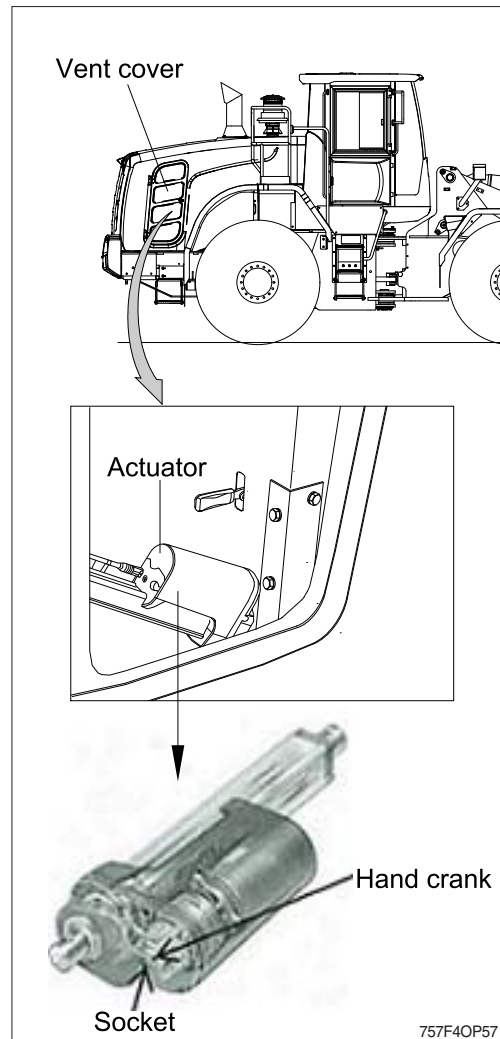

13. ATTACHMENT MANUALLY LOWERING (ENGINE STOPPED)

- 1) The manual lowering valve on the front frame can be manually lowering the attachment linkage if the engine can't work.
- 2) Slowly rotate the lowering valve lever to the OPEN position in order to lower the attachment to the ground.
- 3) After the attachment is resting on the ground, rotate the lowering valve lever to the CLOSE position.

⚠ Keep all personnel away from the boom drop area when lowering the boom with the engine stopped.

⚠ Keep all personnel away from the front linkage when lowering the boom.

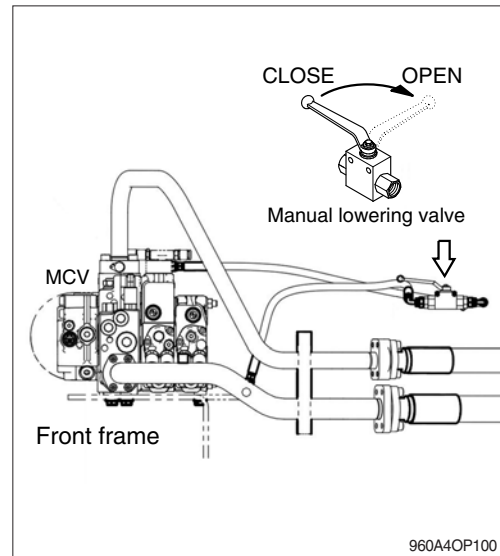

5. TRANSPORTATION

1. ROAD TRAVELING

If it is necessary to travel on a road, observe the followings.

- 1) Comply with regulations regarding this machine for the sake of safety.
- 2) Perform daily inspection before starting the machine.
- 3) Check the air pressure of tires and traveling speed limitations.
 - Air pressure
 - 23.5-25 20PR, L3 : 3.9 kgf/cm² (55 psi)
 - 23.5-25 20PR, L5 : 3.9 kgf/cm² (55 psi)
 - 23.5 R25, L3★(★★) : 4.2 kgf/cm² (60 psi)
 - 23.5 R25, XHA★ : 4.2 kgf/cm² (60 psi)
 - Maximum speed : 39.5 km/hr (24.5 mph)
- 4) When traveling for a long distance, stop every hour or every 40 km (25 mile) to allow tires and other components to cool down and check any abnormality.
- 5) Drive with the bucket empty.
- 6) Travel at a mid-range speed and be careful to drive within the limited speed when driving on a public road.

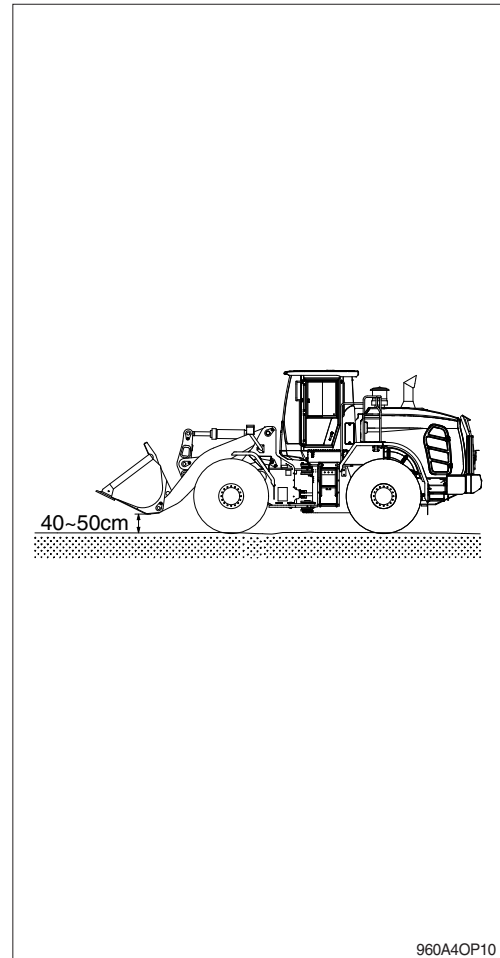

2. PREPARATION FOR TRANSPORTATION

- 1) When transporting the machine, observe the various road rules, road transportation vehicle laws and vehicle limit ordinances, etc.
- 2) Make sure the cooling system has proper anti-freeze if moving machine to a cold climate.
- 3) Select proper trailer after confirming the weight and dimension from the page 2-2~2-5.
- 4) Check the whole route such as the road width, the height of bridge and limit of weight and etc., which will be passed.
- 5) Get the permission from the related authority if necessary.

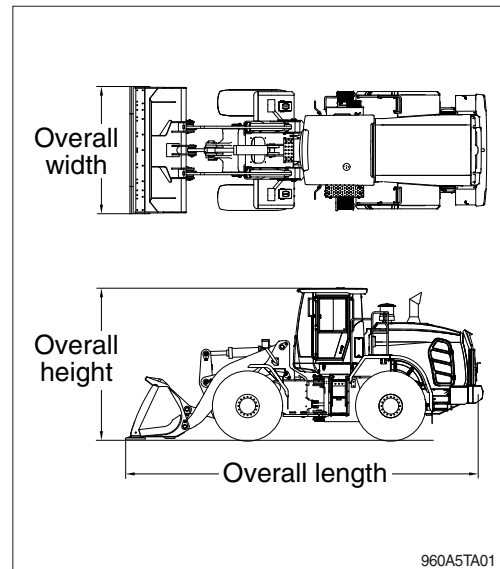

- 6) Prepare gangplank for safe loading referring to the below table and illustration.

A	B
1.0	3.65 ~ 3.85
1.1	4.00 ~ 4.25
1.2	4.35 ~ 4.60
1.3	4.75 ~ 5.00
1.4	5.10 ~ 5.40
1.5	5.50 ~ 5.75

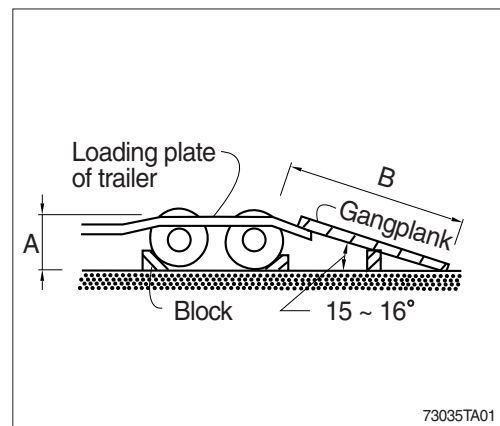

3. LOADING THE MACHINE

- 1) Load and unload the machine on a flat ground.
- 2) Use the gangplank with sufficient length, width, thickness and gradient.
- 3) Move slowly and carefully when the machine is on the gangplank.
Do not change the direction of the machine while it is on the gangplank.

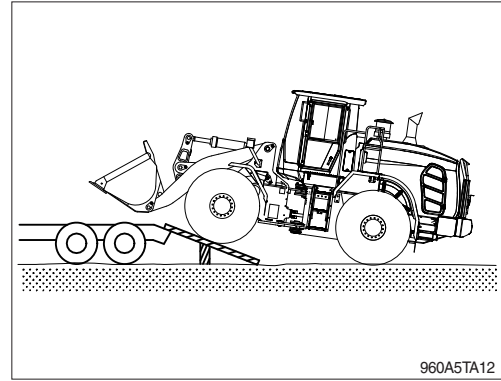

- 4) Do the following after loading the machine to the trailer.
 - (1) Lower the working equipment gently after the location is determined.
 - ※ Place rectangular timber under the bucket cylinder to prevent the damage of it during transportation.
 - ▲ Do not operate any other device when loading.
 - ▲ Balance the load.

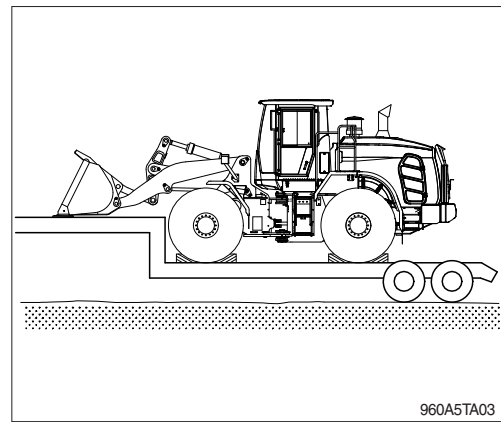

4. FIXING THE MACHINE

- 1) Fix front and rear frame by linking safety lock bar.
- 2) Push the parking brake switch.

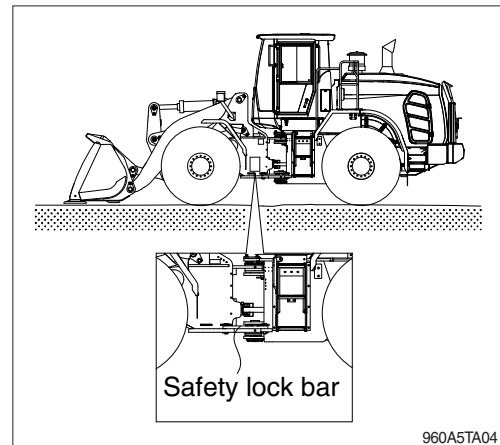

- 3) Push the pilot cut off switch to the OFF position to prevent the hydraulic system from operating.
- 4) Stop the engine, turn the starting switch off and remove the key.

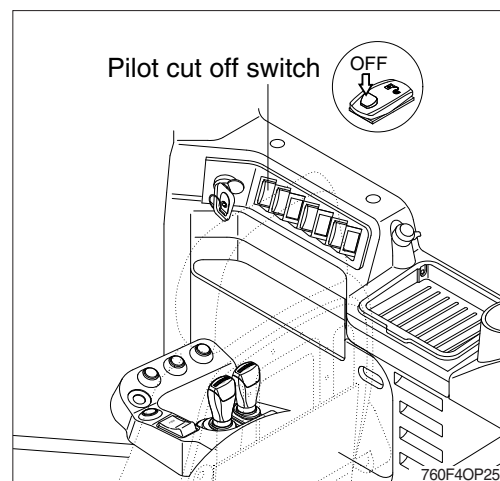

- 5) Secure all locks.

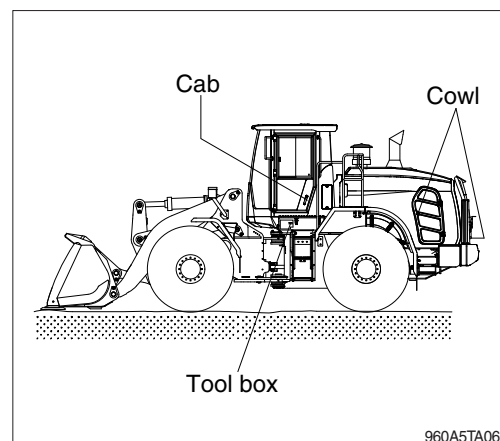

6) Block the tires and fix firmly with wire rope or chain to prevent the machine from moving during transportation.

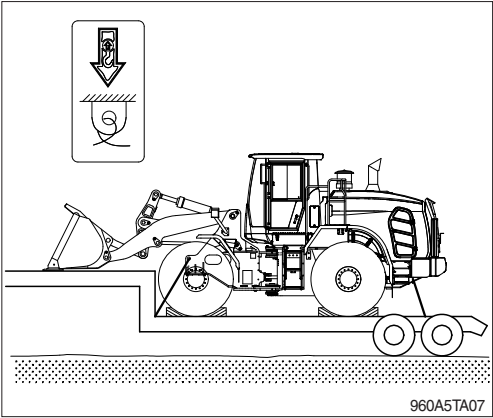

5. LOADING AND UNLOADING BY CRANE

- 1) Check the weight, length, width and height of the machine referring to chapter 2, Specification when you are going to hoist the machine.
- 2) Use long wire rope and stay to keep the distance with the machine as it should avoid to touch with the machine.
- 3) Put a rubber plate contact with wire rope and machine to prevent damage.
- 4) Place crane on the proper place.
- 5) Install the wire rope and stay like the illustration.

- ▲ Make sure wire rope is proper size.
- ▲ Place the safety lock bar and pilot cut off switch to the OFF position to prevent the machine moving when hoisting the machine.
- ▲ The wrong hoisting method or installation of wire rope can cause damage to the machine.
- ▲ Do not load abruptly.
- ▲ Keep area clear of personnel.
- ▲ Attach two wire ropes to the rear of the machine.
Attach two wire ropes to the front of the machine.
Connect the four wire ropes.

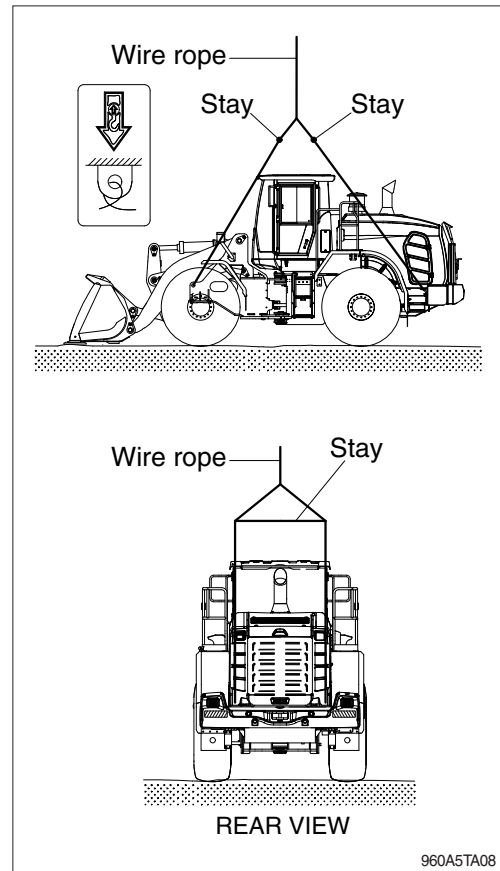

6. TOWING THE MACHINE

- ▲ Personal injury or death could result when towing a disabled machine incorrectly.
- ▲ Block the machine to prevent movement before releasing the brakes. The machine can roll free if it is not blocked.

Except for an emergency, do not tow this machine. If it is inevitable to tow this machine, observe the following.

1) GENERAL

- (1) Parking brake cylinder of the machine is operated by the spring force and released by hydraulic pressure. If the engine does not operate, the brake will be operated to stop the machine.

- (2) When the machine is towed move it for a repair to nearby place at the speed less than 2 km/hr (1.2 mph). Transport it on a trailer, if it has to be moved for a long distance.

- (3) When the steering device and the brake of the machine to be towed can not be operated, transport by trailer.

▲ Be careful when towing.

▲ Be careful that the brake will not work if there is any disorder in the braking system.

- (4) When you tow the machine from the front, attach the tow line to the tow eyes on the front frame (1).

When you tow the machine from the rear, use the tow rear eyes provided for lift & tie (2).

- (5) Do not use a chain for pulling a disabled machine. A chain link can break. This may cause personal injury. Use a wire rope cable with ends that have loops or rings. Place an observer in a safe position in order to watch the pulling procedure. The observer can stop the procedure, if necessary. The procedure should be stopped if the cable starts to break. Also, stop the procedure if the cable starts to unravel. Stop pulling whenever the towing machine moves without moving the towed machine.

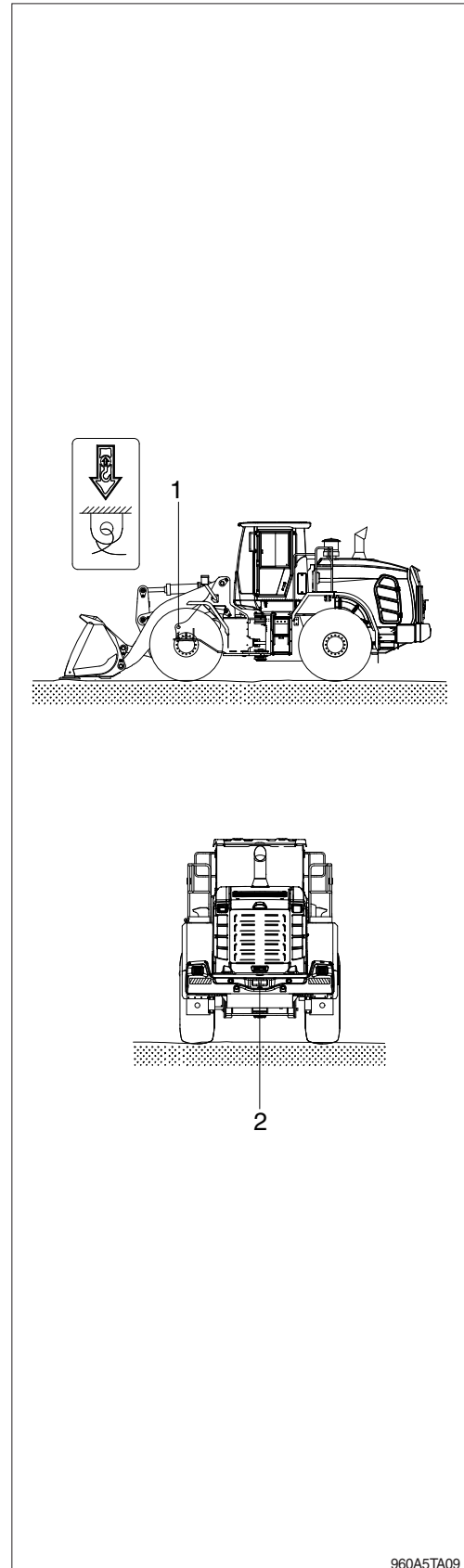

960A5TA09

- (6) Keep the tow line angle to a minimum. Do not exceed a 30 degree angle from the straight ahead position.
 - (7) Quick machine movement could overload the tow line or the tow bar. This could cause the tow line or the tow bar to break. Gradual, steady machine movement will be more effective.
 - (8) Normally, the towing machine should be as large as the disabled machine. Make sure that the towing machine has enough brake capacity, enough weight, and enough power. The towing machine must be able to control both machines for the grade that is involved and for the distance that is involved.
 - (9) You must provide sufficient control and sufficient braking when you are moving a disabled machine downhill.
This may require a larger towing machine or additional machines that are connected to the rear of the disabled machine. This will prevent the machine from rolling away out of control.
 - (10) All situation requirements cannot be listed. Minimal towing machine capacity is required on smooth, level surfaces. On inclines or on surfaces in poor condition, maximum towing machine capacity is required.
 - (11) When any towed machine is loaded, this machine must be equipped with a brake system that is operable from the operator compartment.
- ※ **Consult your HYUNDAI dealer for the equipment that is necessary for towing a disabled machine.**

2) WHEN THE ENGINE WORKS

- (1) When the transmission system or steering wheel is workable and the engine is running, the machine can be towed only for a short distance.
For example, pull the machine out of mud or pull the machine to side of the road.
- (2) The operator of the towed machine should turn the steering wheel into the direction in which the machine is towed.

3) WHEN THE ENGINE DOES NOT WORK

When towing the machine with the engine stopped, do it in the following order.

- (1) The transmission oil does not lubricate the system, so remove the front and rear drive shafts.

- (2) Loosen the steering cylinder as the steering operation is not workable.

Even if the brake is in good condition, the brakes can only be used a limited number of times.

There is no change in the operating force for the brake pedal, but the braking force is reduced each time the pedal is depressed.

- (3) The parking brake is activated by spring and released by hydraulic pressure. If the engine does not work, the brake will be activated.

- ① Release the screw cap (1) in a counter-clockwise direction and unscrew it.
- ② Release the lock nut (2) and unscrew it back to the end of setting screw (3).
- ③ Rotate the setting screw (3) in a clockwise direction until the brake disc is completely free.

▲ In this condition the machine has no parking brake facility and thus must be protected from rolling away by different means. The brake must be adjusted before recommissioning.

- (4) Connect firmly between the traction machine and the towed machine.

Position each traction machine at the front and rear of the machine to be towed.

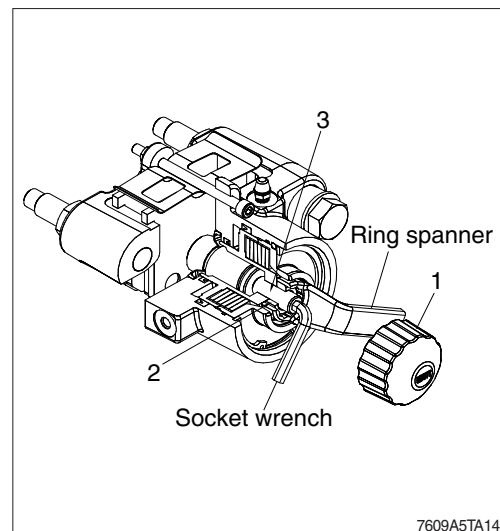

7609A5TA14

1. INSTRUCTIONS

1) INTERVAL OF MAINTENANCE

- (1) You may inspect and service the machine by the period as described at page 6-10 based on service meter of monitor.
- (2) Shorten the interval of inspect and service depending on site condition. (such as dusty area, quarry, sea shore and etc.)
- (3) Practice the entire related details at the same time when the service interval is doubled.
For example, in case of 250 hours, carry out all the maintenance 「each 250 hours, each 100 hours and daily service」 at the same time.

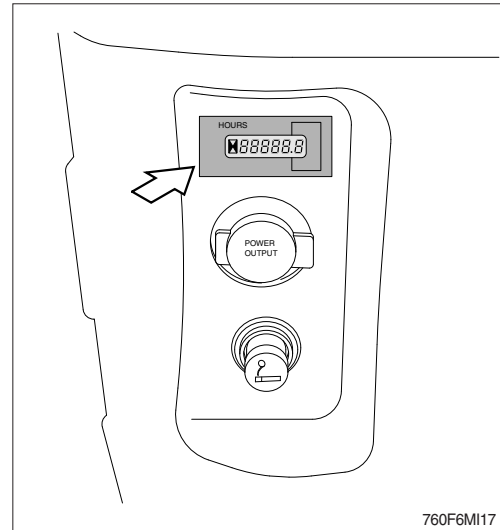

2) PRECAUTION

- (1) Start to maintenance after you have the full knowledge of machine.
- (2) The monitor installed on this machine does not entirely guarantee the condition of the machine.
Daily inspection should be performed according to clause 4, maintenance check list.
- (3) Engine and hydraulic components have been preset in the factory.
Do not allow unauthorized personnel to reset them.
- (4) Drain the used oil and coolant in a container and handle according to the method of handling for industrial waste to meet with regulations of each province or country.
- ▲ **Hot oil and hot components can cause personal injury. Do not allow hot oil or hot components to contact skin.**
- △ **Accumulated grease and oil on the machine is a fire hazard. Remove this debris with steam cleaning or high pressure water, at least every 1000 hours.**
- △ **Inspect the engine compartment for any trash build up. Remove any trash build up from the engine compartment.**
- (5) Ask to your local dealer or Hyundai for the maintenance advice if unknown.

3) PROPER MAINTENANCE

(1) Replace and repair of parts

It is required to replace the wearable and consumable parts such as bucket tooth, cutting edge, filter and etc., regularly.

Replace damaged or worn parts at proper time to keep the performance of machine.

(2) Use genuine parts.

(3) Use the recommended oil.

(4) Remove the dust or water around the inlet of oil tank before supplying oil.

(5) Drain oil when the temperature of oil is warm.

(6) Do not repair anything while operating the engine.

Stop the engine when you fill the oil.

(7) Relieve hydraulic system of the pressure by opening of breather when repairing the hydraulic system.

(8) Confirm if the cluster is in the normal condition after completion of service.

(9) For more detail information of maintenance, please contact local Hyundai dealer.

※ **Be sure to start the maintenance after fully understand the chapter 1, Safety hints.**

4) RELIEVING THE PRESSURE IN THE HYDRAULIC SYSTEM

※ Spouting of oil can cause the accident when loosening the cap or hose right after the operating of the machine as the machine or oil is on the high pressure on the condition.

Be sure to relieve the pressure in the system before repairing hydraulic system.

- (1) Place the machine in parking position, and stop the engine.

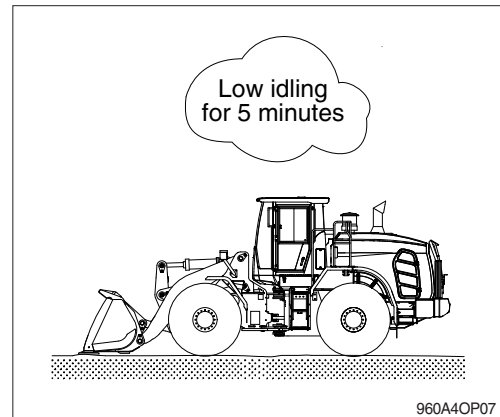

- (2) Rotate the cap nut counter-clockwise by hand and push the rod to release the air pressure.

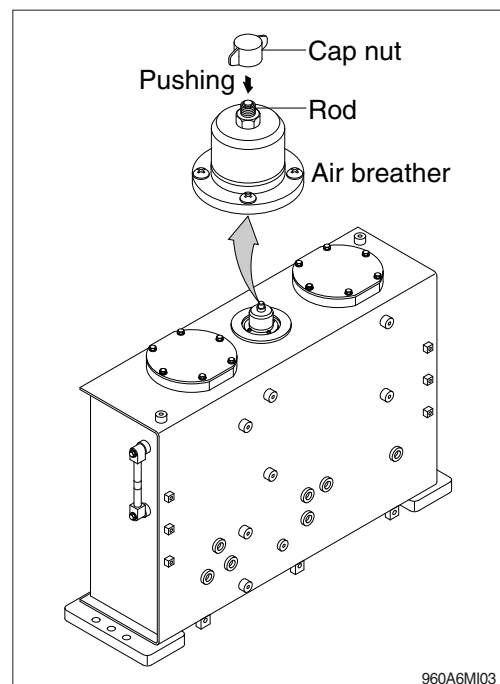

5) PRECAUTION WHEN INSTALLING HYDRAULIC HOSES OR PIPES

- (1) Be particularly careful that the joint of hose, pipe and functioning item are not damaged.
Avoid contamination.
- (2) Assemble after cleaning the hose, pipe and joint of functioning item.
- (3) Use genuine parts.
- (4) Do not assemble the hose in the condition of twisted or sharp radius.
- (5) Keep the specified tighten torque.

6) PERIODICAL REPLACEMENT OF SAFETY PARTS

- (1) These are the parts which the operator can not judge the remained lifetime of them by visual inspection.
- (2) Repair or replace if an abnormality of these parts is found even before the recommended replacement interval.

Periodical replacement of safety parts	Interval
Fuel hose (engine-tank)	Every 2 years
Hose of steering system	
Packing, seal and O-ring of steering cylinder	
Hose of brake system	
Piston seal and packing of boom, bucket cylinder	

- ※ 1. **Replace the O-ring and gasket at the same time when replace the hose.**
- ※ 2. **Replace clamp at the same time if the hose clamp is cracked when checking and replacing the hose.**

2. TIGHTENING TORQUE

Use following table for unspecified torque.

1) BOLT AND NUT

(1) Coarse thread

Bolt size	8.8T		10.9T		12.9T	
	kgf · m	lbf · ft	kgf · m	lbf · ft	kgf · m	lbf · ft
M 6×1.0	0.8 ~ 1.2	5.8 ~ 8.6	1.2 ~ 1.8	8.7 ~ 13.0	1.5 ~ 2.1	10.9 ~ 15.1
M 8×1.25	2.0 ~ 3.0	14.5 ~ 21.6	2.8 ~ 4.2	20.3 ~ 30.4	3.4 ~ 5.0	24.6 ~ 36.1
M10×1.5	4.0 ~ 6.0	29.0 ~ 43.3	5.6 ~ 8.4	40.5 ~ 60.8	6.8 ~ 10.0	49.2 ~ 72.3
M12×1.75	6.8 ~ 10.2	50.0 ~ 73.7	9.6 ~ 14.4	69.5 ~ 104	12.3 ~ 16.5	89.0 ~ 119
M14×2.0	10.9 ~ 16.3	78.9 ~ 117	16.3 ~ 21.9	118 ~ 158	19.5 ~ 26.3	141 ~ 190
M16×2.0	17.9 ~ 24.1	130 ~ 174	25.1 ~ 33.9	182 ~ 245	30.2 ~ 40.8	141 ~ 295
M18×2.5	24.8 ~ 33.4	180 ~ 241	34.8 ~ 47.0	252 ~ 340	41.8 ~ 56.4	302 ~ 407
M20×2.5	34.9 ~ 47.1	253 ~ 340	49.1 ~ 66.3	355 ~ 479	58.9 ~ 79.5	426 ~ 575
M22×2.5	46.8 ~ 63.2	339 ~ 457	65.8 ~ 88.8	476 ~ 642	78.9 ~ 106	570 ~ 766
M24×3.0	60.2 ~ 81.4	436 ~ 588	84.6 ~ 114	612 ~ 824	102 ~ 137	738 ~ 991
M30×3.5	120 ~ 161	868 ~ 1164	168 ~ 227	1216 ~ 1641	202 ~ 272	1461 ~ 1967

(2) Fine thread

Bolt size	8.8T		10.9T		12.9T	
	kgf · m	lbf · ft	kgf · m	lbf · ft	kgf · m	lbf · ft
M 8×1.0	2.1 ~ 3.1	15.2 ~ 22.4	3.0 ~ 4.4	21.7 ~ 31.8	3.6 ~ 5.4	26.1 ~ 39.0
M10×1.25	4.2 ~ 6.2	30.4 ~ 44.9	5.9 ~ 8.7	42.7 ~ 62.9	7.0 ~ 10.4	50.1 ~ 75.2
M12×1.25	7.3 ~ 10.9	52.8 ~ 78.8	10.3 ~ 15.3	74.5 ~ 110	13.1 ~ 17.7	94.8 ~ 128
M14×1.5	12.4 ~ 16.6	89.7 ~ 120	17.4 ~ 23.4	126 ~ 169	20.8 ~ 28.0	151 ~ 202
M16×1.5	18.7 ~ 25.3	136 ~ 182	26.3 ~ 35.5	191 ~ 256	31.6 ~ 42.6	229 ~ 308
M18×1.5	27.1 ~ 36.5	196 ~ 264	38.0 ~ 51.4	275 ~ 371	45.7 ~ 61.7	331 ~ 446
M20×1.5	37.7 ~ 50.9	273 ~ 368	53.1 ~ 71.7	384 ~ 518	63.6 ~ 86.0	460 ~ 622
M22×1.5	51.2 ~ 69.2	370 ~ 500	72.0 ~ 97.2	521 ~ 703	86.4 ~ 116	625 ~ 839
M24×2.0	64.1 ~ 86.5	464 ~ 625	90.1 ~ 121	652 ~ 875	108 ~ 146	782 ~ 1056
M30×2.0	129 ~ 174	933 ~ 1258	181 ~ 245	1310 ~ 1772	217 ~ 294	1570 ~ 2126

2) PIPE AND HOSE (FLARE type)

Thread size	Width across flat (mm)	kgf · m	lbf · ft
1/4"	19	4	28.9
3/8"	22	5	36.2
1/2"	27	9.5	68.7
3/4"	36	18	130
1"	41	21	152
1-1/4"	50	35	253

3) PIPE AND HOSE (ORFS type)

Thread size	Width across flat (mm)	kgf · m	lbf · ft
9/16-18	19	4	28.9
11/16-16	22	5	36.2
13/16-16	27	9.5	68.7
1-3/16-12	36	18	130
1-7/16-12	41	21	152
1-11/16-12	50	35	253

4) FITTING

Thread size	Width across flat (mm)	kgf · m	lbf · ft
1/4"	19	4	28.9
3/8"	22	5	36.2
1/2"	27	9.5	68.7
3/4"	36	18	130
1"	41	21	152
1-1/4"	50	35	253

5) TIGHTENING TORQUE OF MAJOR COMPONENT

No.	Descriptions	Bolt size	Torque		
			kgf · m	lbf · ft	
1	Engine	Engine mounting bolt, nut (rubber, 2EA)	M20×2.5	57.9 ± 8.7	419 ± 63
2		Engine mounting bolt (bracket, 8EA)	M12×1.75	11.7 ± 1.8	84.6 ± 13.0
3		Engine mounting bolt (T/C housing, 3EA)	M10×1.5	4.6 ± 0.9	33.3 ± 6.5
4		Engine mounting bolt (flywheel, 8EA)	M10×1.5	4.5 ± 0.6	32.5 ± 4.3
5		Fan motor mounting bolt	M12×1.75	12.8 ± 3.0	92.6 ± 21.7
6		Radiator mounting bolt	M16×2.0	29.7 ± 5.9	215 ± 42.7
7		Fuel tank mounting bolt, nut	M16×2.0	29.7 ± 4.5	215 ± 32.5
8	Hydraulic system	Main pump housing mounting bolt	M16×2.0	29.7 ± 4.5	215 ± 32.5
9		Fan & brake pump housing mounting bolt	M10×1.5	6.9 ± 1.4	50 ± 10.1
10		Main control valve mounting bolt	M12×1.75	12.8 ± 3.0	92.6 ± 21.7
11		Steering unit mounting bolt	M10×1.5	6.9 ± 1.4	50 ± 10.1
12		Steering valve (EHPS) mounting bolt	M8×1.25	2.5 ± 0.5	18.1 ± 3.6
13		Brake valve mounting bolt	M8×1.25	2.5 ± 0.5	18.1 ± 3.6
14		Cut-off valve mounting bolt	M8×1.25	2.5 ± 0.5	18.1 ± 3.6
15		EH control block mounting bolt	M8×1.25	2.5 ± 0.5	18.1 ± 3.6
16		Safety valve	M10×1.5	6.9 ± 1.4	50 ± 10.1
17		Hydraulic oil tank mounting bolt	M16×2.0	29.7 ± 4.5	215 ± 32.5
18	Power train system	Transmission mounting bolt, nut (rubber, 2EA)	M24×3.0	100 ± 15	723 ± 108
19		Transmission mounting bolt (bracket, 6EA)	M20×2.5	46.3 ± 7.0	335 ± 50.6
20		Front axle mounting bolt, nut	M33×2.0	225 ± 20	1627 ± 145
21		Rear axle support mounting bolt, nut	M36×3.0	308 ± 46.2	2227 ± 334
22		Tire mounting nut	M22×1.5	79 ± 2.5	571 ± 18.1
23		Drive shaft joint mounting bolt	1/2-20UNF	15 ± 2.0	108 ± 14.5
24	Others	Counterweight mounting bolt	M30×3.5	199 ± 30	1439 ± 216
25		Operator's seat mounting bolt	M8×1.25	3.4 ± 0.8	24.6 ± 5
26		ROPS Cab mounting bolt (4EA)	M30×3.5	199 ± 29.9	1440 ± 216
		ROPS Cab mounting nut (4EA)	M16×2.0	20.5 ± 4.7	148 ± 34

3. SPECIFICATION OF FUEL, COOLANT AND LUBRICANTS

1) NEW MACHINE

New machine used and filled with following lubricants.

Description	Specification
Engine oil (API CK-4)	SAE 15W-40, ^{★2} SAE 5W-40
DEF/AdBlue®	ISO 22241 (32.5% high-purity urea and 67.5 deionized water)
Hydraulic oil	Hyundai genuine long life hydraulic oil (ISO VG 46, VG 68 only) Conventional hydraulic oil (ISO VG15 ^{★2}) Hyundai Bio Hydraulic Oil (HBHO, ISO VG 46)
Transmission oil	SAE 15W-40
Axle oil	[★] Refer to below list
Grease	Lithium base grease NLGI No. 2
Fuel	ASTM D975-No. 2, ^{★1} Ultra low sulfur diesel
Coolant	ASTM D6210 Mixture of 50% ethylene glycol base antifreeze and 50% water Mixture of 60% ethylene glycol base antifreeze and 40% water ^{★2}

SAE : Society of Automotive Engineers

API : American Petroleum Institute

ISO : International Organization for Standardization

NLGI : National Lubricating Grease Institute

ASTM : American Society of Testing and Material

DEF : Diesel Exhaust Fluid

DEF compatible with AdBlue®

[★] Recommended oil list

- BP TERRAC SUPER TRANSMISSION 10W-30

- CASTROL AGRI TRANS PLUS 10W-30

- MOBILFLUID 426

- SHELL SPIRAX S4 TXM

- TOTAL DYNATRANS MPV

^{★1} Ultra low sulfur diesel

- sulfur content ≤ 15 ppm

^{★2} Cold region

Russia, CIS, Mongolia

2) RECOMMENDED OILS

HYUNDAI genuine lubricating oils have been developed to offer the best performance and service life for your equipment. These oils have been tested according to the specifications of HYUNDAI and, therefore, will meet the highest safety and quality requirements.

We recommend that you use only HYUNDAI genuine lubricating oils and grease officially approved by HYUNDAI.

- ※ Using any lubricating oils other than HYUNDAI genuine products may lead to a deterioration of performance and cause damage to major components.
- ※ Do not mix HYUNDAI genuine oil with any other lubricating oil as it may result in damage to the systems of major components.
- ※ Do not use any engine oil other than that specified above, as it may clog the diesel particulate filter(DPF).
- ※ For HYUNDAI genuine lubricating oils and grease for use in regions with extremely low temperatures, please contact HYUNDAI dealers.

Service point	Kind of fluid	Capacity ℓ (U.S. gal)	Ambient temperature °C (°F)							
			-50 (-58)	-30 (-22)	-20 (-4)	-10 (14)	0 (32)	10 (50)	20 (68)	30 (86)
Engine oil pan	Engine oil	18 (4.8)	SAE 15W-40							
			*2SAE 5W-40							
			SAE 0W-40							
DEF/ AdBlue® tank	Mixture of urea and deionized water	37.1 (9.8)	ISO 22241, High-purity urea + deionized water (32.5 : 67.5)							
Transmission	Engine oil	33 (8.7)	SAE 10W-30							
			SAE 15W-40							
Axle *4	UTTO	FR : 35 (9.2) FR : 45 (11.9)*6 RR : 35 (9.2)	*Refer to below list							
Hydraulic tank	Hydraulic oil	Tank: 110 (29.1) System: 200 (52.8)	*2 ISO VG 15							
			ISO VG 46, HBHO VG 46*5							
			ISO VG 68							
Fuel tank	Diesel fuel*1	260 (68.6)	*2 ASTM D975 NO.1							
			ASTM D975 NO.2							
Fitting (grease nipple)	Grease	As required	*2 NLGI NO.1							
			NLGI NO.2							
Radiator (reservoir tank)	Mixture of antifreeze and soft water*3	42 (11.1)	Ethylene glycol base permanent type (50 : 50)							
			*2 Ethylene glycol base permanent type (60 : 40)							

SAE : Society of Automotive Engineers

API : American Petroleum Institute

ISO : International Organization for Standardization

NLGI : National Lubricating Grease Institute

ASTM : American Society of Testing and Material

UTTO : Universal Tractor Transmission Oil

DEF : Diesel Exhaust Fluid

DEF compatible with AdBlue®

*1 Ultra low sulfur diesel
- sulfur content ≤ 15 ppm

* Recommended oil list

- BP TERRAC SUPER TRANSMISSION 10W-30

- CASTROL AGRI TRANS PLUS 10W-30

- MOBILFLUID 426

- SHELL SPIRAX S4 TXM

- TOTAL DYNATRANS MPV

*2 Cold region : Russia, CIS, Mongolia

*3 Soft water : City water or distilled water

*4 If the machine is equipped with axle oil cooler,
refer to page 6-44.

*5 Hyundai Bio Hydraulic Oil

*6 HL960A HD

4. MAINTENANCE CHECK LIST

Scheduled maintenance is the normal maintenance necessary to provide proper and efficient machine operation. To protect your investment and prolong the service life of your machine, follow the scheduled maintenance list below.

1) EVERY 10 HOURS SERVICE

Check items	Service	Page
Hydraulic oil level	Check, Add	6-35
Engine oil level	Check, Add	6-15
Radiator coolant level	Check, Add	6-17
Belt tension & damage	Check	6-22, 23
Fuel pre-filter element (water)	Drain	6-25
DEF/AdBlue® tank	Check, Add	6-29
Charge air piping	Check	6-21
Cooling fan	Check	6-22
After treatment exhaust piping	Check	-
Air intake piping	Check	-
Air cleaner and dust ejection valve	Check	-
Crankcase breather tube	Check	-

2) EVERY 50 HOURS SERVICE

Check items	Service	Page
Attachment pins	Lubricate	6-48
Tire (air)	Check, Add	6-38
Drive shaft (flange bearing, front, center, rear)	Lubricate	6-45
Steering cylinder pins	Lubricate	6-45
Rear axle pivot	Lubricate	6-45
Fuel tank (water, sediment)	Drain	6-25

3) INITIAL 250 HOURS SERVICE

Check items	Service	Page
Engine oil and filter	Change	6-15, 16, 17
Fuel filter element	Replace	6-26
Fuel pre-filter element	Replace	6-25
Transmission oil and filter	Change	6-41, 42
Front and rear axle oil	Change	6-44
Hydraulic oil return filter	Replace	6-36
Pilot line filter element	Replace	6-37
Pressure filter element	Replace	6-37

4) EVERY 250 HOURS SERVICE

Check items	Service	Page
Wheel nuts	Check, Tight	6-38, 39
Battery (voltage) / Battery cable and connections	Check	6-50, 51
Air conditioner and heater filter (inner and outer)	Check, Clean	6-53

5) EVERY 500 HOURS SERVICE

Check items	Service	Page
Radiator, oil cooler, change air cooler, condenser	Check, Clean	6-21

6) EVERY 800 HOURS SERVICE

Check items	Service	Page
Engine oil *	Change	6-15, 16, 17
Engine oil filter *	Replace	6-15, 16, 17

* Change oil and filter every 500 hours when using API CJ-4.

7) EVERY 1000 HOURS SERVICE

Check items	Service	Page
Fuel filter element	Replace	6-26
Fuel pre-filter element	Replace	6-26
Drive belt, cooling fan, belt tensioner	Check	6-22, 23
Hydraulic oil return filter	Replace	6-36
Pilot line filter element	Replace	6-37
Pressure filter element	Replace	6-37
Hydraulic tank air breather element	Replace	6-37
Center pivot pin	Lubricate	6-45
Transmission oil	Change	6-41, 42
Transmission oil filter	Replace	6-41, 42
Aircon and heater outer filter	Replace	6-53
Air cleaner element (primary)*	Clean	6-24

* When working in dusty environments, more frequent cleaning is highly recommended.

8) EVERY 1500 HOURS SERVICE

Check items	Service	Page
Front axle oil	Change	6-44
Rear axle oil	Change	6-44
Axle oil filter (opt)	Replace	6-44

9) EVERY 2000 HOURS SERVICE

Check items	Service	Page
Engine cleaning	Clean	6-30
Vibration damper (rubber, viscous)	Check	6-31
Hydraulic oil* ¹	Change	6-36
HBHO (Hyundai Bio Hydraulic Oil, ISO VG 46)* ²	Change	6-36
Coolant, cooling system and antifreeze	Change, Flush	6-17, 18, 19, 20
Hydraulic oil suction strainer	Check, Clean	6-36
Airconditioner and heater inner filter	Replace	6-53
DEF/AdBlue® tank filter	Replace	6-29
Hoses, fittings, clamps (fuel, coolant, hydraulic)	Check, Retighten, Replace	-

*¹ Conventional hydraulic oil

*² If do not want to change HBHO every 2000 hours, contact HYUNDAI dealer and ask about SAMPLING.

10) EVERY 4500 HOURS SERVICE

Check items	Service	Page
DEF/AdBlue® supply module filter *	Replace	6-29

★ When working in dusty environments, inspection per 1500 hours is highly recommended.

11) EVERY 5000 HOURS SERVICE

Check items	Service	Page
Overhead set (shop inspection)	Adjust	6-32, 33, 34
Hydraulic oil* ³	Change	6-36

*³ Hyundai genuine long life hydraulic oil

12) WHEN REQUIRED

Check items	Service	Page
Air cleaner element		
· Safety	Replace	6-24
· Primary	Clean, Replace	6-24
Air conditioner and heater		
· Outer filter	Replace	6-53
· Inner filter	Clean, Replace	6-53
DPF (diesel particulate filter)	Clean	6-30

5. MAINTENANCE CHART

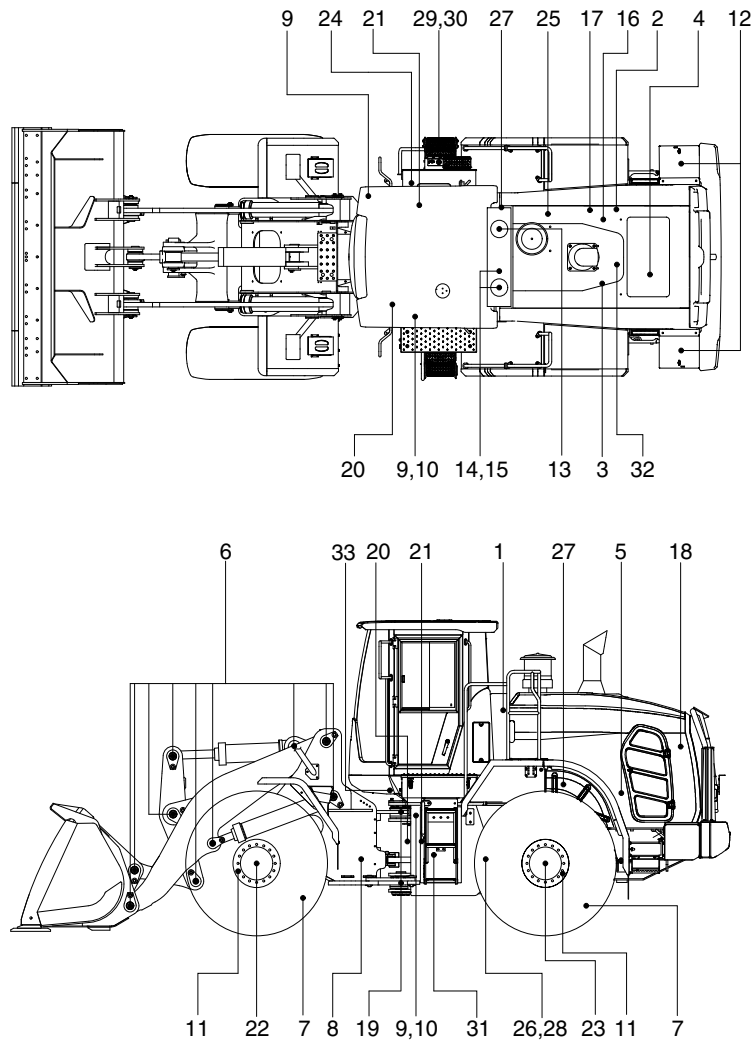

960A6M110

Caution

1. Service intervals are based on the hour meter reading.
2. The number of each item shows the lubrication point on the machine.
3. Stop engine while filling oil, and use no open flames.
4. For other details, refer to the service manual.

- EO : Engine oil - GO : Gear oil
- C : Coolant - DEF : DEF/AdBlue®
- HO : Hydraulic oil - PGL : Grease
- UTTO : Refer to page 6-9.

Service interval	No.	Description	Service action	Oil symbol	Capacity ℓ (U.S.gal)	Service points No.
10 Hours or daily	1	Hydraulic oil level	Check, Add	HO	110 (29.1)	1
	2	Engine oil level	Check, Add	EO	18 (4.8)	1
	4	Radiator coolant level	Check, Add	C	42 (11.1)	1
	5	Fan belt tension & damage	Check, Adjust	-	-	1
	17	Fuel pre-filter (water)	Drain	-	-	1
	29	DEF/AdBlue® tank	Check, Add	DEF	37.1 (9.8)	1
50 Hours or weekly	6	Attachment pins	Lubricate	PGL	-	13
	7	Tire (air)	Check, Add	-	-	4
	8	Drive shaft (flange bearing)	Lubricate	PGL	-	1
	9	Steering cylinder pin	Lubricate	PGL	-	4
	10	Rear axle pivot	Lubricate	PGL	-	2
	26	Drive shaft sleeve yoke	Lubricate	PGL	-	2
	28	Drive shaft journal bearing assy	Lubricate	PGL	-	5

Service interval	No.	Description	Service action	Oil symbol	Capacity ℓ (U.S.gal)	Service points No.
250 Hours	11	Wheel nuts	Check, Tight	-	-	64
	12	Battery voltage, cable and connection	Check, Add	-	-	2
	24	Aircon and heater inner and outer filter	Check, Clean	-	-	2
Initial 250 Hours	2	Engine oil	Change	EO	18 (4.8)	1
	3	Engine oil filter	Replace	-	-	1
	13	Hydraulic oil return filter	Replace	-	-	1
	16	Fuel filter element	Replace	-	-	1
	17	Fuel pre-filter element	Replace	-	-	1
	20	Transmission oil	Change	EO	33 (8.7)	1
	21	Transmission oil filter	Replace	-	-	1
	22	Axle oil (front)	Change	UTTO	See 6-9	3
	23	Axle oil (rear)	Change	UTTO	See 6-9	3
	31	Pilot line filter element	Replace	-	-	1
33	Pressure filter element	Replace	-	-	1	
500 Hours	18	Radiator, oil cooler, CAC, condenser	Clean	-	-	5
800 Hours	2	Engine oil	Change	EO	18 (4.8)	1
	3	Engine oil filter	Replace	-	-	1
1000 Hours	13	Hydraulic oil return filter	Replace	-	-	1
	14	Hydraulic tank air breather element	Replace	-	-	1
	16	Fuel filter element	Replace	-	-	1
	17	Fuel pre-filter element	Replace	-	-	1
	19	Center pivot pin	Lubricate	PGL	-	2
	20	Transmission oil	Change	EO	33 (8.7)	1
	21	Transmission oil filter	Replace	-	-	1
	24	Airconditioner and heater outer filter	Replace	-	-	1
	25	Air cleaner element (primary)	Clean	-	-	1
	31	Pilot line filter element	Replace	-	-	1
33	Pressure filter element	Replace	-	-	1	
1500 Hours	22	Axle oil (front)	Change	UTTO	See 6-9	3
	23	Axle oil (rear)	Change	UTTO	See 6-9	3
	-	Axle oil filter (opt)	Replace	-	-	1
2000 Hours	1	Hydraulic oil* ¹	Change	HO	110 (29.1)	1
	1	Hydraulic oil (HBHO)* ²	Change	-	110 (29.1)	1
	4	Radiator coolant	Change	C	42 (11.1)	1
	15	Hydraulic oil suction strainer	Check, Clean	-	-	1
	24	Air conditioner and heater inner filter	Replace	-	-	1
	-	Engine cleaning, Vibration damper	Clean, Check	-	-	2
	-	Hoses, fittings, clamps (fuel, coolant, hydraulic)	Check, Retighten, Replace	-	-	-
	30	DEF/AdBlue® tank filter	Replace	-	-	1
4500 Hours	27	DEF/AdBlue® supply module filter	Replace	-	-	1
5000 Hours	1	Hydraulic oil* ³	Change	HO	110 (29.1)	1
	-	Overhead set (shop inspection)	Adjust	-	-	1
When required	24	Air conditioner and heater outer filter	Replace	-	-	1
		Air conditioner and heater inner filter	Clean, Replace	-	-	1
	25	Air cleaner element (safety)	Replace	-	-	1
		Air cleaner element (primary)	Clean, Replace	-	-	1

*¹ Conventional hydraulic oil *² Hyundai Bio Hydraulic Oil *³ Hyundai genuine long life hydraulic oil

6. SERVICE INSTRUCTION

1) CHECK ENGINE OIL LEVEL

Check the oil level with the machine on a flat ground before starting engine.

- (1) Pull out the dipstick and wipe with a clean cloth.
 - (2) Check the oil level by inserting the dipstick completely into the hole and pulling out again.
 - (3) If oil level is LOW, add oil and then check again.
- ※ If the oil is contaminated or diluted, change the oil regardless of the regular change interval.
 - ※ Check oil level after engine has been stopped for 15 minutes.
 - ▲ Do not operate unless the oil level is in the normal range.

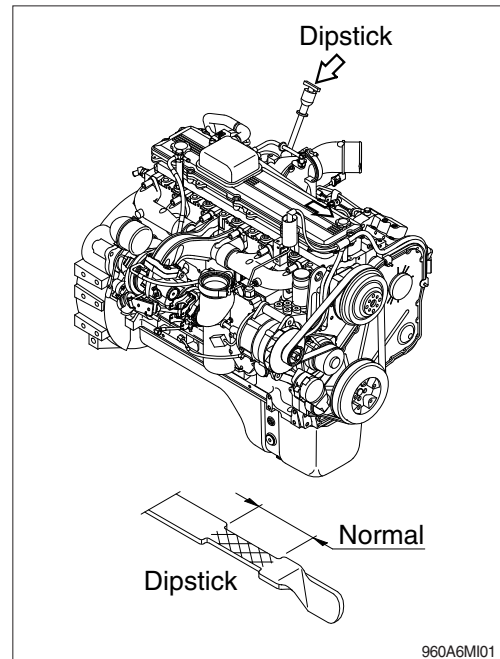

2) REPLACEMENT OF ENGINE OIL AND OIL FILTER

- (1) Operate the engine until the coolant temperature reaches 60°C (140°F). Shut off the engine.
- (2) Turn the stopper to the open position and allow the oil to drain.
 - Wrench size : 10 mm
- ※ A drain pan with a capacity of 20 liters (5.3 U.S.gallons) will be adequate.

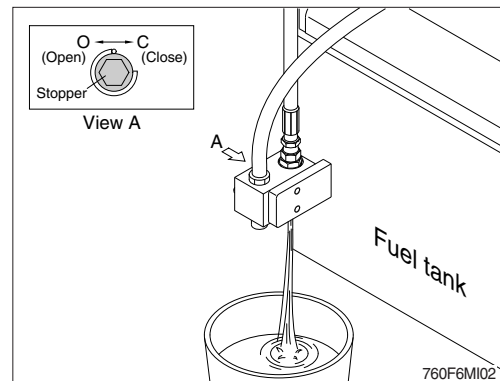

- (3) Clean the area around the oil filter head.
- (4) Use oil filter wrench to remove the oil filter.
- (5) Clean the gasket surface of oil filter head.
- ※ The O-ring can stick on the filter head; make sure it is removed.

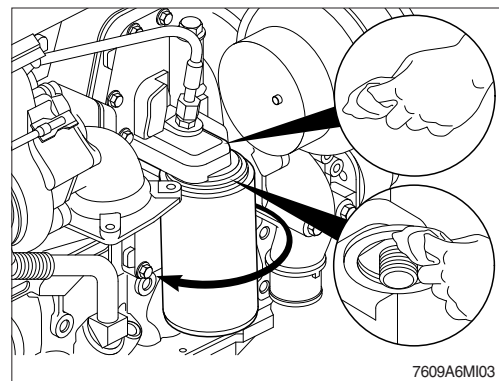

(6) Apply a light film of lubricating oil to the gasket sealing surface before installing the filter.

※ **Fill the filter with clean lubricating oil.**

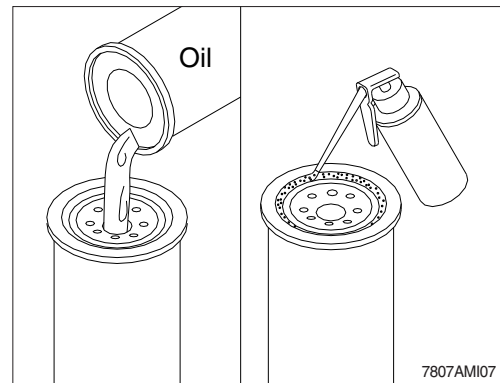

(7) Install the filter to the filter head.

Tighten the filter until the gasket contacts the filter head surface.

Tighten 3/4 to 1 turn after gasket makes contact with the filter head.

※ **Mechanical over-tightening may distort the threads or damage the filter element seal.**

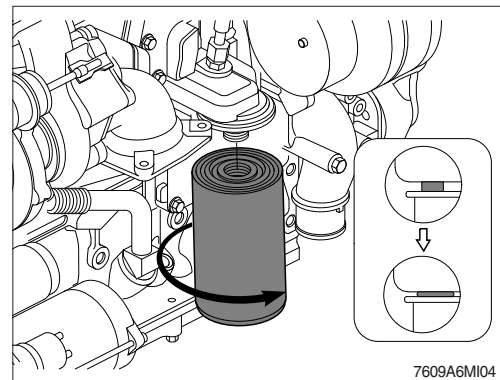

(8) Turn the stopper to the close position.

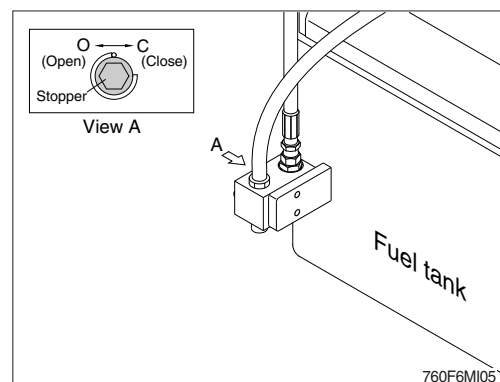

(9) Fill the engine with clean oil to the proper level.

· Quantity : 18 ℓ (4.8 U.S.gallons)

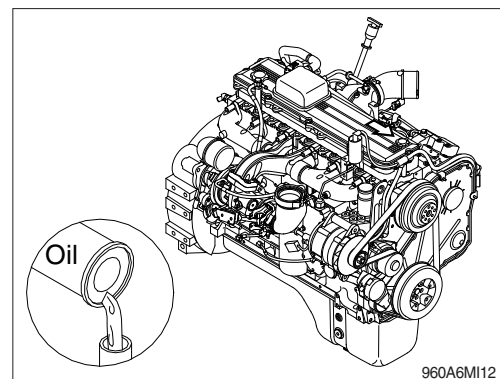

- (10) Operate the engine at low idle and inspect for leaks at the filter and the drain plug.
Shut the engine off and check oil level with dipstick. Allow 15 minutes for oil to drain down before checking.

※ **Do not overfill the engine with oil.**

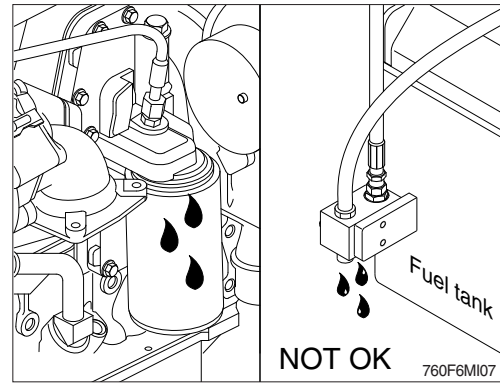

3) CHECK COOLANT LEVEL

- (1) Check the engine fault code on the monitor.
- (2) If you following fault codes exist, check the coolant level.
- SPN : 111, FMI : 18
- Coolant level is low.
 - SPN : 111, FMI : 1
- Coolant level is the most severely low.
- (3) Add the mixture of antifreeze and water after removing the cap of the surge tank if coolant is not sufficient.

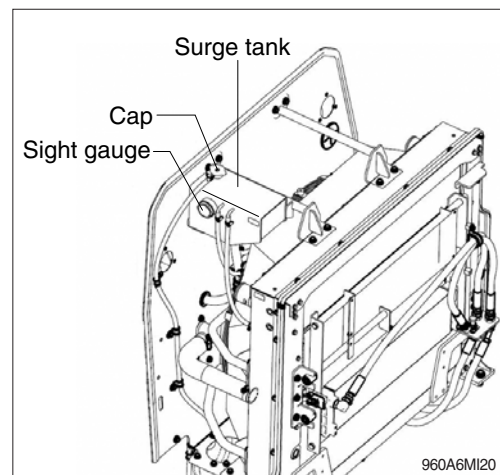

- (4) Replace gasket of surge tank cap when it is damaged.

▲ **Do not remove the surge tank cap from a hot engine. Wait until the coolant temperature is below 50°C (120°F) before removing the cap. Heated coolant spray or steam can cause personal injury.**

※ **Do not add cold coolant to a hot engine ; engine castings can be damaged. Allow the engine to cool to below 50°C (120°F) before adding coolant.**

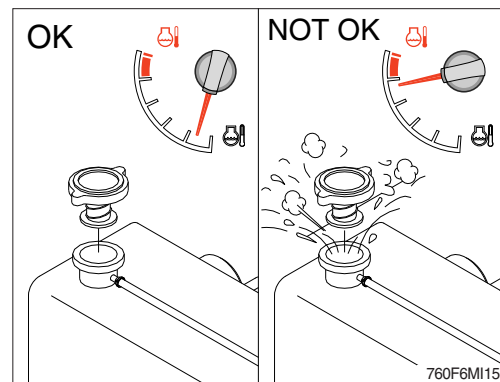

4) FLUSHING AND REFILLING OF RADIATOR

(1) Change coolant

⚠ Avoid prolonged and repeated skin contact with used antifreeze. Such prolonged repeated contact can cause skin disorders or other bodily injury.

Avoid excessive contact-wash thoroughly after contact.

Keep out of reach of children.

⚠ Protect the environment : Handling and disposal of used antifreeze can be subject to federal, state, and local law regulation.

Use authorized waste disposal facilities, including civic amenity sites and garages providing authorized facilities for the receipt of used antifreeze.

If in doubt, contact your local authorities for guidance as to proper handling of used antifreeze.

⚠ Wait until the temperature is below 50°C (120°F) before removing the coolant system cap. Failure to do so can cause personal injury from heated coolant spray.

Drain the cooling system by turning the stopper to the open position.

A drain pan with a capacity of 45 liters (11.9 U.S.gallons) will be adequate in most applications.

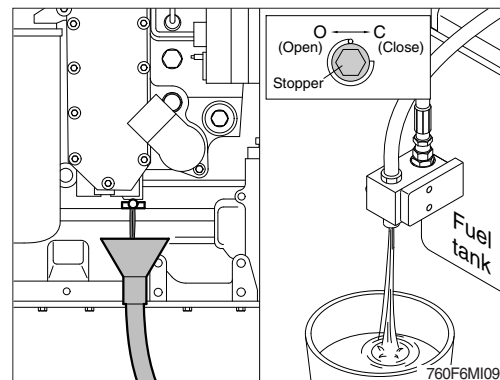
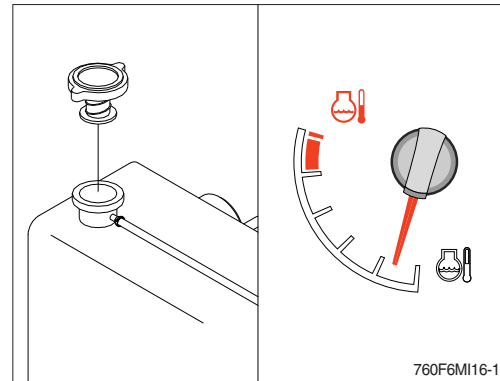

(2) Flushing of cooling system

① Fill the system with a mixture of sodium carbonate and water (or a commercially available equivalent).

※ Use 0.5 kg (1.0 pound) of sodium carbonate for every 23 liters (6.0 U.S. gallons) of water.

※ Do not install the cap. The engine is to be operated without the cap for this process.

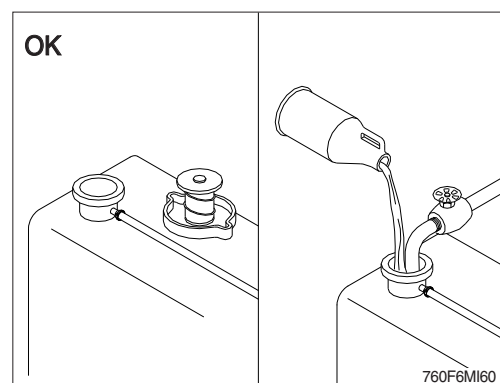

※ During filling, air must be vented from the engine coolant passages.

The system must be filled slowly to prevent air locks. Wait 2 to 3 minutes to allow air to be vented, then add mixture to bring the level to the top.

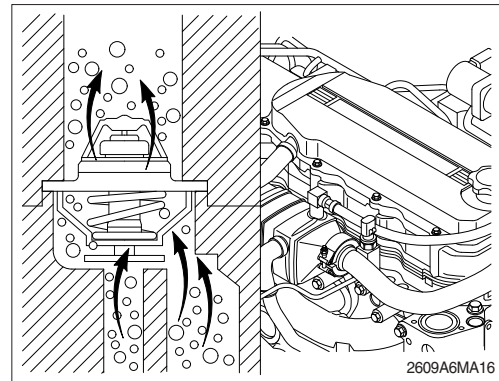

② Operate the engine for 5 minutes with the coolant temperature above 80°C (176°F). Shut the engine off, and drain the cooling system.

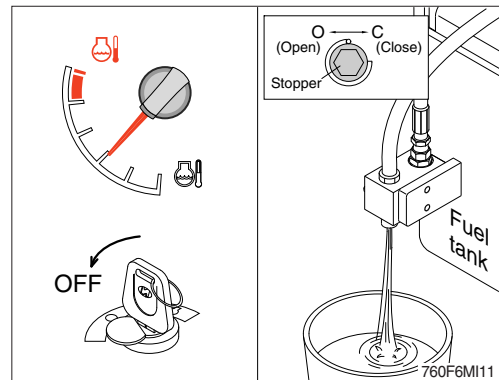

③ Fill the cooling system with clean water.

※ Be sure to vent the engine and aftercooler for complete filling.

※ Do not install the surge tank cap or the new coolant filter.

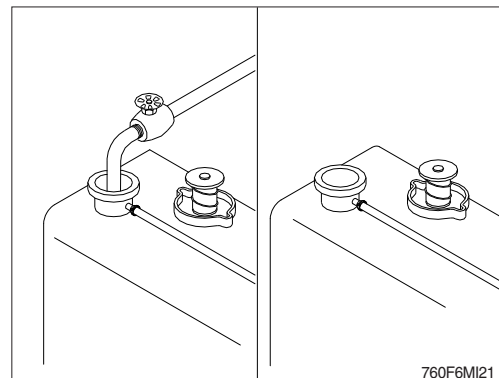

④ Operate the engine for 5 minutes with the coolant temperature above 80°C (176°F). Shut the engine off, and drain the cooling system.

※ If the water being drained is still dirty, the system must be flushed again until the water is clean.

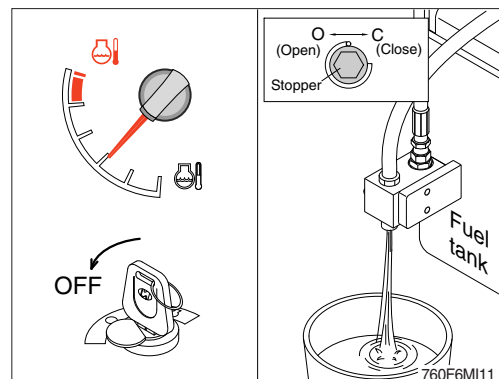

(3) Cooling system filling

① Use a mixture of 50 percent soft water and 50 percent ethylene glycol antifreeze to fill the cooling system. Refer to the page 6-9.

- ※ **Never use water alone for coolant.**
This can result in damage from corrosion.
- ※ **Do not use hard water such as river water or well water.**

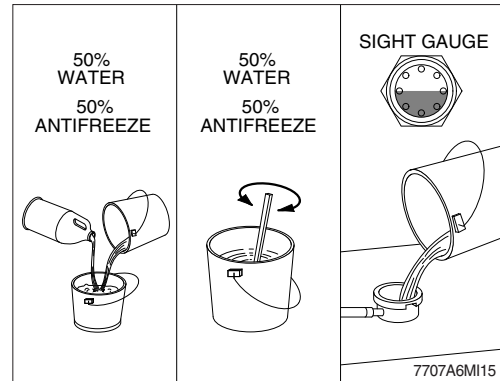

② The system has a maximum fill rate of 19 liters (5.0 U.S. gallons) per minute. Do not exceed this fill rate.

- ※ **The system must be filled slowly to prevent air locks.**
During filling, air must be vented from the engine coolant passage.

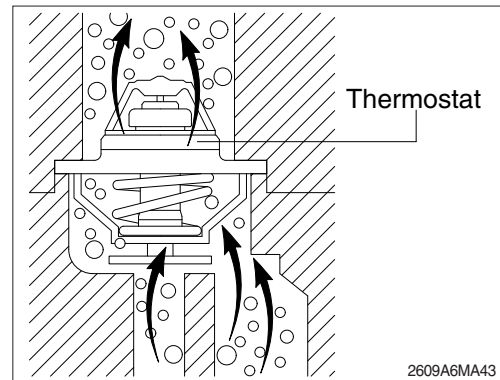

③ Install the cap. Operate the engine until it reaches a temperature 80°C (176°F), and check for coolant leaks.

Check the coolant level again to make sure the system is full of coolant.

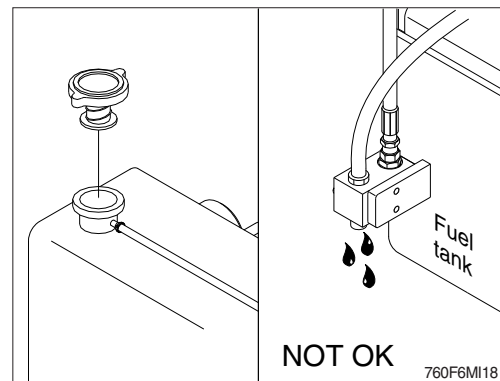

5) CLEAN RADIATOR AND OIL COOLER

Check, and if necessary, clean and dry outside of radiator and oil cooler. After working in a dusty place, clean radiator more frequently.

- (1) Visually inspect the radiator for clogged radiator fins.
- (2) Use 550 kPa (80 psi) air pressure to blow the dirt and debris from the fins.
Blow the air in the opposite direction of the fan air flow.
- (3) Visually inspect the radiator for bent or broken fins.
※ If the radiator must be replaced due to bent or broken fins which can cause the engine to overheat, refer to the manufacturer's replacement procedures.
- (4) Visually inspect the radiator for core and gasket leaks.

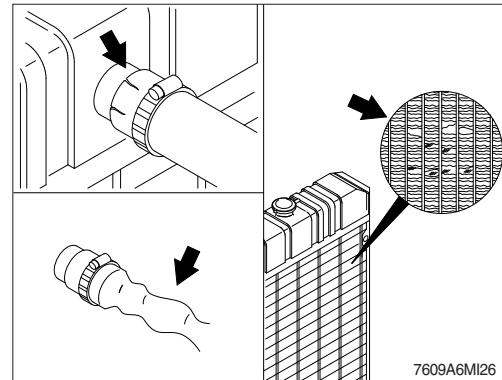
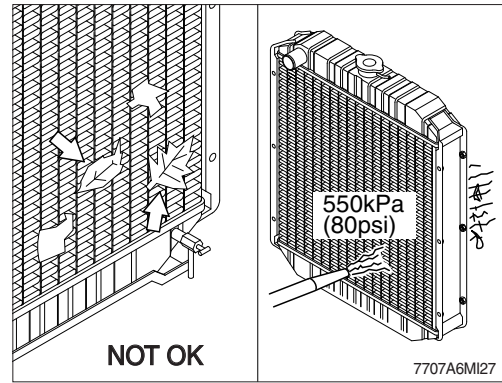

6) CHECK CHARGE AIR COOLER AND PIPING

- (1) Inspect the charge air cooler for dirt and debris blocking the fins. Check for cracks, holes, or other damage. If damage is found, please contact hyundai distributor.
- (2) Inspect the charge air piping and hoses for leaks, holes, cracks, or loose connections. Tighten the hose clamps if necessary.

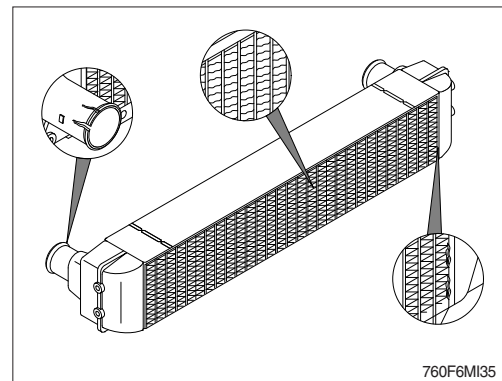

7) FAN BELT

- (1) Use the belt tension gage to measure the belt tension.

· Fan belt tension : 11.3 kg (25 lb)

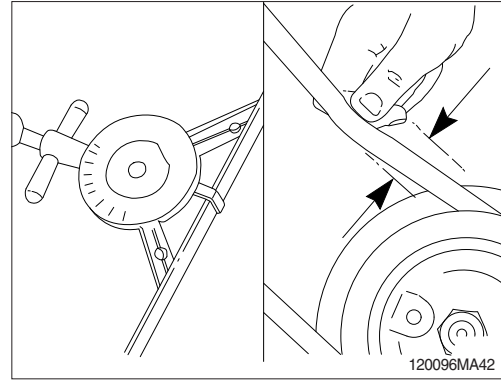

- (2) Inspect the fan belt for damage.

- ① Transverse (across the belt) cracks are acceptable.
- ② Longitudinal (direction of belt ribs) cracks that intersect with transverse cracks are not acceptable.
- ③ Replace the belt if it is frayed or has pieces of material missing.

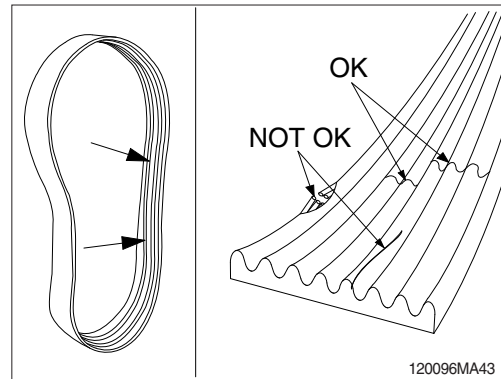

- (3) Inspect the idle and drive pulleys for wear or cracks.

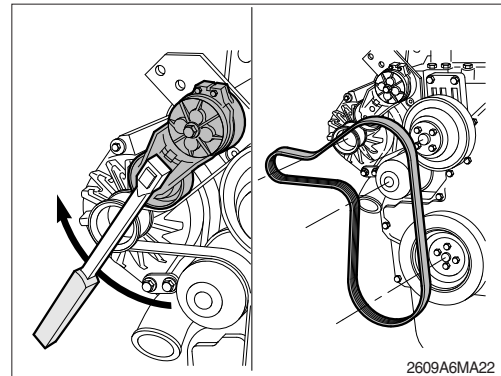

8) INSPECTION OF COOLING FAN

▲ Personal injury can result from a fan blade failure. Never pull or pry on the fan. This can damage the fan blade and cause fan failure.

※ Rotate the crankshaft by using the engine barring gear.

※ A visual inspection of the cooling fan is required daily.

Check for cracks, loose rivets, and bent or loose blades.

Check the fan to make sure it is securely mounted. Tighten the capscrews if necessary.

Replace any fan that is damaged.

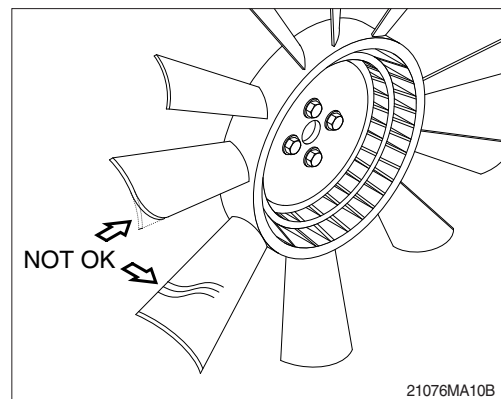

9) FAN BELT TENSIONER

- (1) With the engine stopped, check the tensioner arm, pulley, and stops for cracks. If any cracks are found, the tensioner must be replaced.

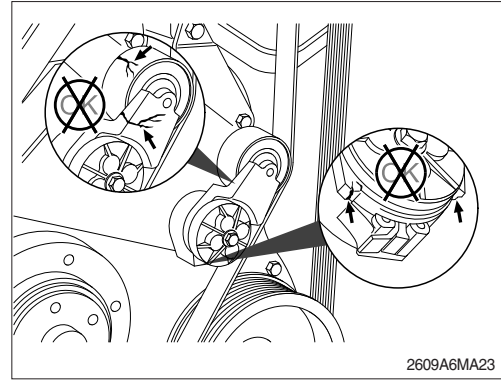

- (2) With the belt installed, verify that neither tensioner arm stop is in contact with the spring case stop.

After replacing the belt, if the tensioner arm stops are still in contact with the spring case stop, replace the tensioner.

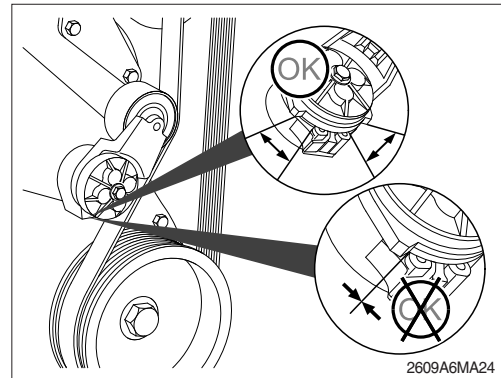

- (3) With the belt removed, verify that the tensioner arm stop is in contact with the spring case stop. If these two are not touching, the tensioner must be replaced.

※ After replacing the belt, if the tensioner arm stop is still in contact with the spring case stop, the tensioner **MUST** be replaced.

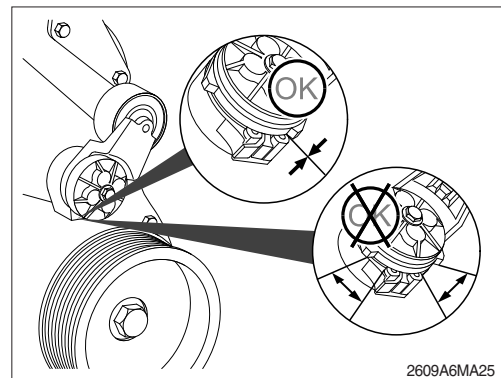

- (4) Check the location of the drive belt on the belt tensioner pulley. The belt should be centered on, or close to the middle of, the pulley. Misaligned belts, either too far forward or backward, can cause belt wear, belt roll-offs, or increase uneven tensioner bushing wear.

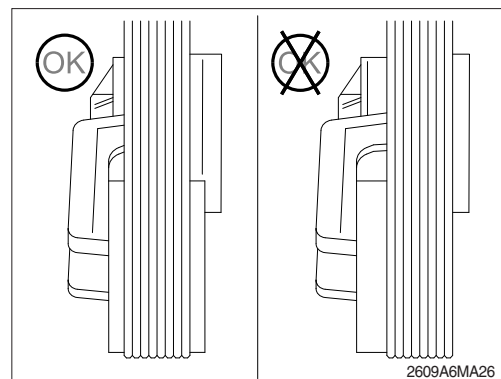

10) CLEANING OF AIR CLEANER

(1) Primary element

- ① Open the cover and remove the element.
- ② Wipe all contaminant and debris from inside the housing body.
- ③ Do not clean the filter element by striking or hitting the filter against any object to shake the debris from the filter element.
- ④ Clean the filter element with compressed air.
 - a. Remove dust from filter element by directing the compressed air into the opening of the air filter element.
 - b. Use 3 kg/cm^2 (40 psi) maximum air pressure and hold the compressed air nozzle at least 2.5 cm (1") away from the pleats while cleaning. Make sure to keep the clean side of air filter free of debris.
- ⑤ Visually inspect for damage to the filter elements and components. Use a light source to help identify any defects in the media. If any defects are observed discard the filter element and replace with a new primary filter element.
 - a. Before any type of cleaning, a visual inspection of the filter is needed. If there is any damage to the filter body, gaskets or endplates, do not clean or reuse; the filter should be discarded. Always clean filters in a clean environment, observe strict inspection procedures and repackage filters immediately after the cleaning process with appropriate materials.
 - b. Use observe proper safety precautions and dispose of waste materials in an environmentally compliant manner.
- ⑥ Re-install filter element into the air housing.
- ⑦ Replace the primary element at the fourth cleaning.

(2) Safety element

The safety filter element should never be cleaned since the safety filter is the last barrier to contaminant before it reaches engine/equipment. The useful life of the safety filter is equivalent to that of the primary air filter only if the primary filter element is being regularly cleaned. If the primary filter element is not cleaned, the safety filter should be changed at every third primary air filter change or after one year of continuous service, whichever occurs first.

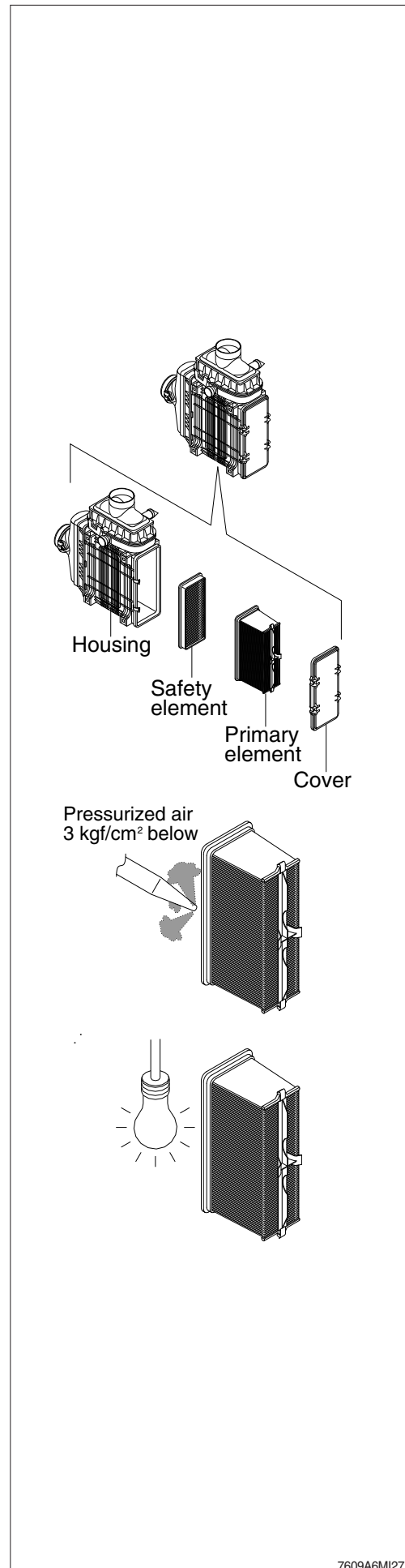

7609A6M127

11) FUEL TANK

- (1) Fill fuel fully when system the operation to minimize water condensation, and check it with fuel gauge before starting the machine.
 - (2) Drain the water and sediment in the fuel tank by opening the drain cock.
 - ※ Be sure to LOCK the cap of fuel tank.
 - ※ Remove the strainer of the fuel tank and clean it if contaminated.
- ▲ Stop the engine when refueling.**
All lights and flames shall be kept at a safe distance while refueling.

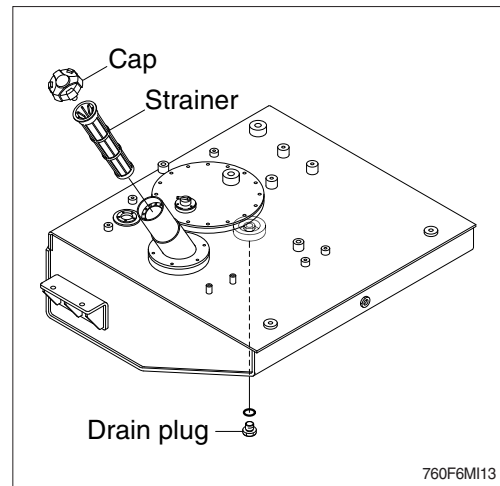

12) PREFILTER

- ※ Inspect or drain the collected water daily and replace the element every 1000hours.

(1) Drain water

- ① Open the drain valve to evacuate water for 10 seconds.
 - ② Close drain valve.
- ※ Do not use tools.
 - ※ Don't tighten up a drain valve so strong.

(2) Replace element

- ① Loosen the air vent plug and drain the unit of fuel. Follow "Drain water" instructions above.
- ② Remove the drain pipe and WIF sensor from filter body.
- ③ Remove the filter body from filter head.
- ④ Pre-fill a new filter body with fuel and lubricate a gasket on the new filter body.
- ⑤ Install the filter on the filter head. Tighten the filter until the gasket contacts the filter head surface. Tighten the prefilter an additional 3/4 turn after contact.
- ⑥ Connect the drain pipe and WIF sensor to filter body.

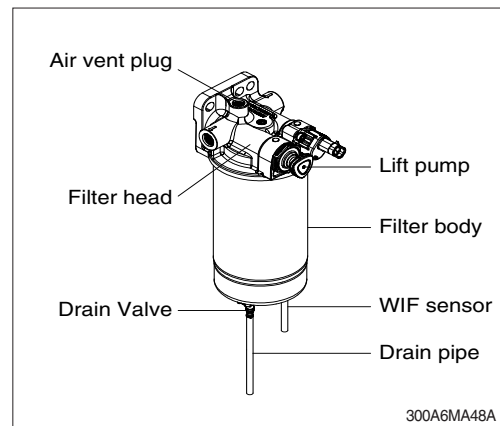

(3) Air bleeding

- ① Do hand-priming the lift pump repeatedly until air bubbles comes out from air vent hole completely.
 - ② Tighten the air vent plug to its origin position.
- ▲ **The fuel pump, high-pressure fuel lines, and fuel rail contain very high-pressure fuel. Do not loosen any fittings while the engine is running. Personal injury and property damage can result. Wait at least 10 minutes after shutting down the engine before loosening any fittings in the high-pressure fuel system to allow pressure to decrease to a lower level.**

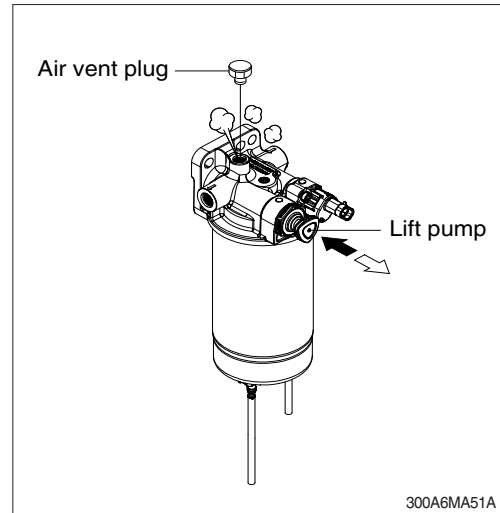

14) REPLACEMENT OF FUEL FILTER

- (1) Use 1" wrench, loosen and remove the filter and clean the gasket surface.
 - ※ **Make sure O-ring does not stick to filter head. Remove O-ring with screwdriver if necessary.**
- (2) Lubricate the fuel filter O-ring with clean lubricating oil.
- (3) Install the filter on the filter head. Tighten the filter until the gasket contacts the filter head surface. Tighten the fuel filter an additional 3/4 turn after contact.
 - ※ **Mechanical overtightening can distort the threads or damage the filter element seal.**
- (4) Relieve the air after mounting.
 - ※ **Do not pre-fill an on-engine fuel filter with fuel. The system must be primed after the fuel filter is installed. Pre filling the fuel filter can result in debris entering the fuel system and damaging fuel system components.**
 - ※ **Check for fuel leakage after the engine starts. If air is in the fuel system, the engine will not start. Start engine after bleeding the air according to the method of bleeding air.**

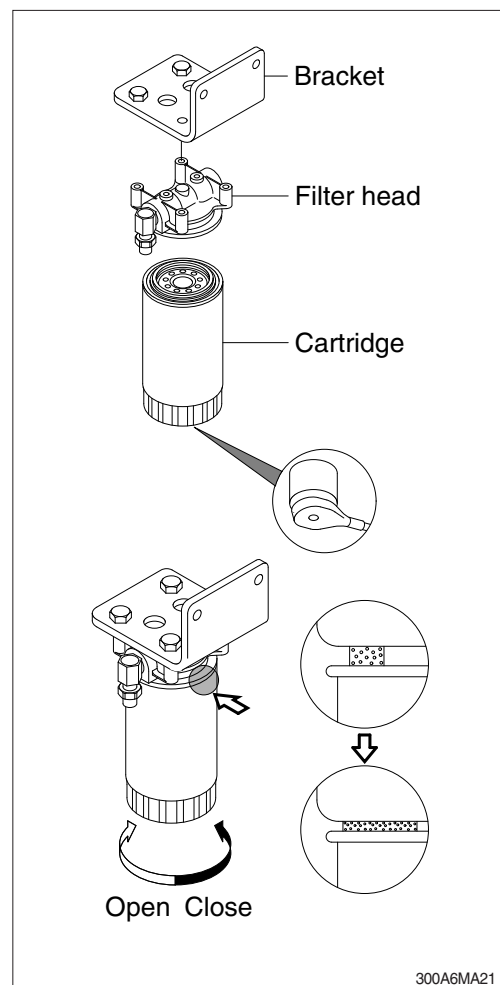

15) LEAKAGE OF FUEL

- ▲ Be careful and clean the fuel hose, injection pump, fuel filter and other connections as the leakage from these part can cause fire.

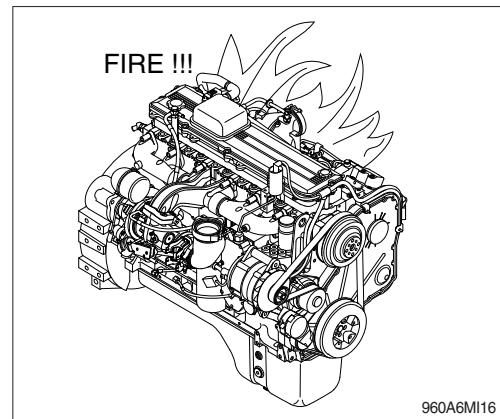

16) DEF/AdBlue® TANK

- (1) The DEF/AdBlue® tank level must be checked daily with DEF/AdBlue® level on LCD. Refer to the page 3-12.
 - ※ The DEF/AdBlue® tank is located on the right side of the machine.
Make sure that the filler filter in cap is clean. If it is dirty, clean the filler filter with clean water and refit it.

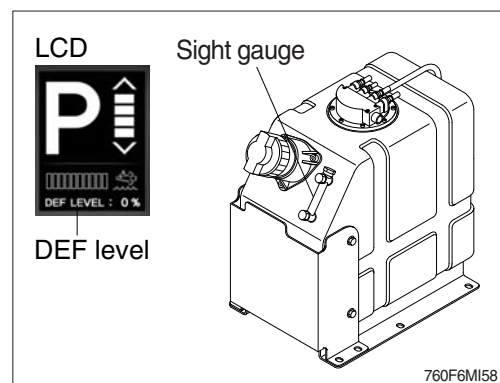

- (2) If the DEF/AdBlue® level is found to below, DEF/AdBlue® must be added.
- (3) When fill the tank with DEF/AdBlue®, check the sight gauge and don't fill up "F" level line to prevent overflow.

- ▲ It is unlawful to tamper with or remove any component of the aftertreatment system. It is also unlawful to use a catalyst solution that does not meet the specifications provided or the operate the machine with no catalytic solution.
 - ※ Be careful to entering dust, sand or other contamination substance when you refill the DEF/AdBlue® into the tank. Otherwise, fatal problem such as engine idle locking, derating or engine stopping can be happen.

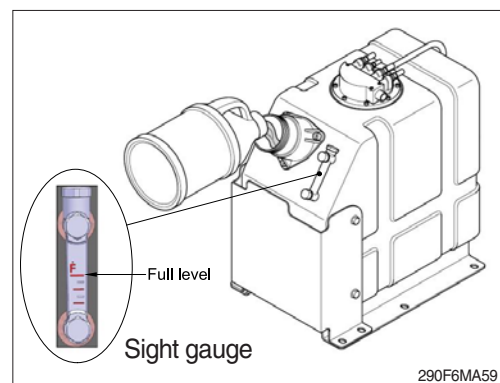

17) DEF/AdBlue® TANK FILTER

(1) The filter is located on DEF/AdBlue® tank.

(2) Loosen the screws (10EA) and remove the cover.

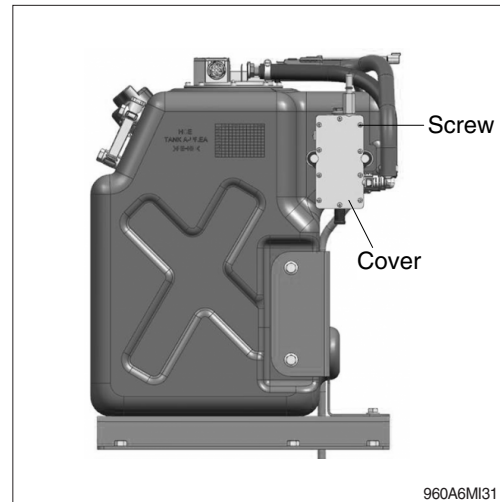

(3) Loosen the clip and remove the DEF/AdBlue® tank filter.

(4) Replace the filter and install the cover and screws.

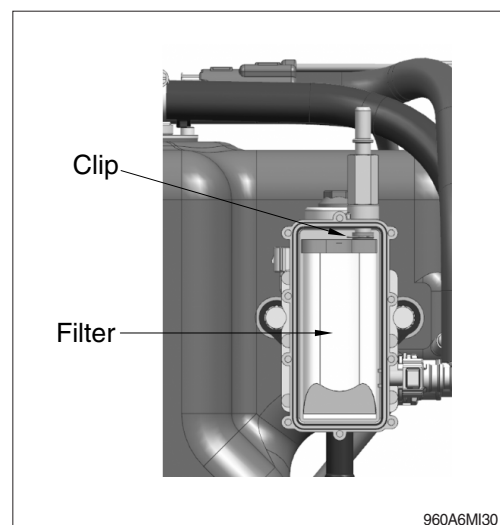

18) DEF/AdBlue® SUPPLY MODULE FILTER

(1) Inspect the area around the DEF/AdBlue® supply module filter case for signs of leakage.

※ Turn OFF the master switch located in tool box on the left side of rear frame.

(2) Remove the filter case with the biotube pump spray and filter.

(3) Remove the filter and biotube pump spray from the case.

※ Clean the case inside and biotube pump spray.

(4) Insert a new filter and biotube pump spray into the case and tighten the case.

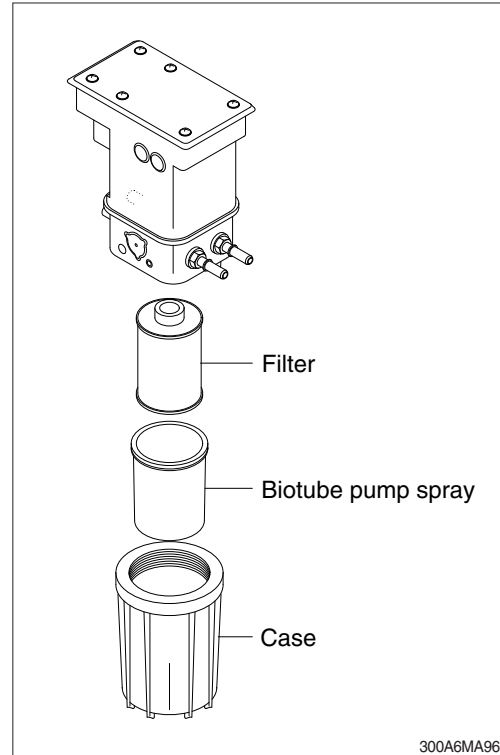

19) ENGINE CLEANING

▲ When using a steam cleaner, wear safety glasses or a face shield, as well as protective clothing. Hot steam can cause serious personal injury.

※ Turn OFF the master switch mounted electric box.

- (1) Steam is the recommended method of cleaning a dirty engine or a piece of equipment.
- (2) Protect all electrical components, openings, and wiring from the full force of the cleaner spray nozzle.
- (3) Components to protect include, but are not limited to the following:
 - Electrical components and connectors
 - Wiring harnesses
 - Electronic control module (ECM) and connectors.
 - Belts and hoses
 - Bearings (ball or taper roller)

△ Soap, solvent, or water ingress into air intake system can cause engine damage.

△ Do not directly spray or allow soap, solvent, or water to enter any passages, ports, or cowlings that lead to the engine air intake system.

20) DPF (diesel particulate filter) CLEANING

- (1) The diesel particulate filter can not be cleaned for maintenance purpose using conventional tools.
- (2) The diesel particulate filter needs to be cleaned and checked using an approved cleaning machine at a authorized service center.

※ Please contact your Hyundai service center or local dealer.

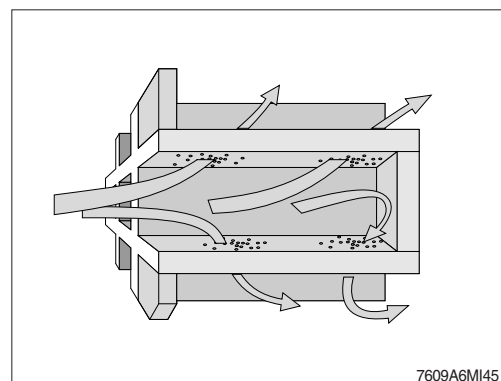
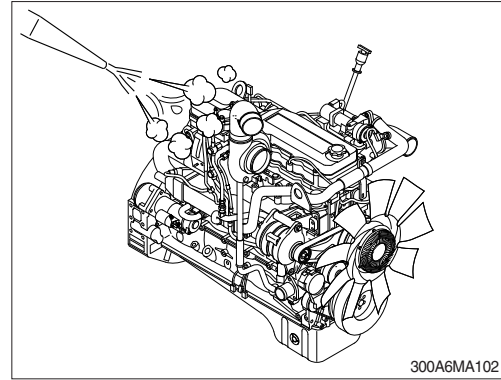

21) VIBRATION DAMPER

(1) Rubber

- ① Check the index lines (A) in the vibration damper hub (B) and the inertia member (C). If the lines are more than 1.59 mm (1/16 in) out of alignment, replace the vibration damper.

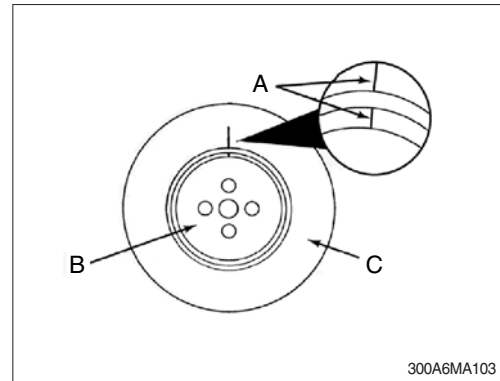

- ② Inspect the rubber member for deterioration. If pieces of rubber are missing or if the elastic member is more than 3.18 mm (1/8 in) below the metal surface, replace the damper.
- ③ Look for forward movement of the damper ring on the hub. Replace the vibration damper if any movement is detected.

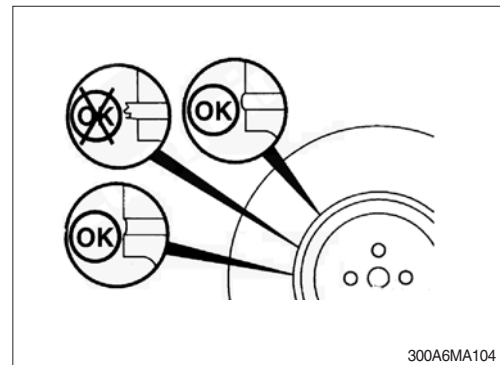

(2) Viscous

※ **The silicone fluid in the vibration damper will become solid after extended service and will make the damper inoperative. An inoperative vibration damper can cause major engine or drivetrain failures.**

- ① Check the vibration damper for evidence of fluid loss, dents, and wobble. Inspect the vibration damper thickness for any deformation or raising of the damper cover plate.
- ② If any of these conditions are identified, contact your local Cummins authorized repair location to replace the vibration damper. movement is detected.

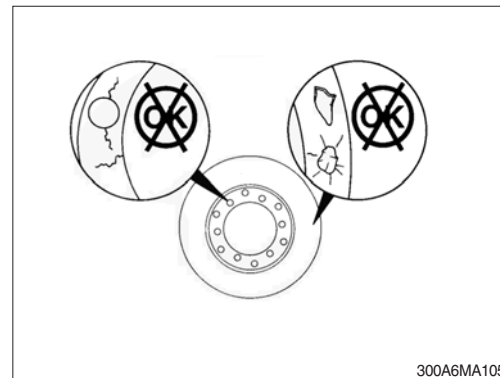

22) OVERHEAD SET ADJUSTMENT

- ※ This procedures are perform the repair shop.
- ※ Service tools
 - Cummins barring tool, p/no. 5299073
 - Feeler gauge
- ※ Remove the rocker lever cover and gasket, refer to engine maintenance manual.

- (1) Use the barring tool, to rotate the crankshaft until the number 1 cylinder is at topdead center (TDC).

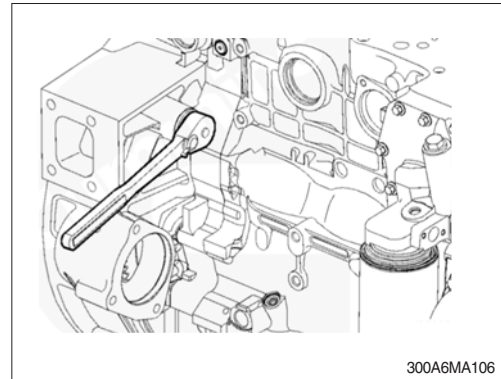

- (2) The TDC indicator is on the vibration damper. Align the vibration damper so the TDC indicator is at the 12 o'clock position.

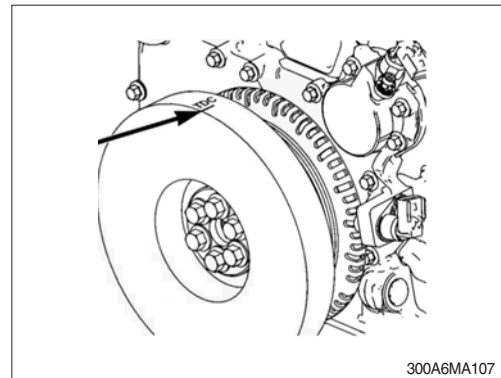

- (3) If no TDC mark is present on either the vibration damper or the crankshaft speed indicator ring, align the large gap in the crankshaft speed indicator ring to the 5 o'clock position (2). The dowel pin will be visible in the 9 o'clock position (1). Check that both number 1 cylinder rocker levers are loose. If they are not loose, rotate the crankshaft 360 degrees and check again.

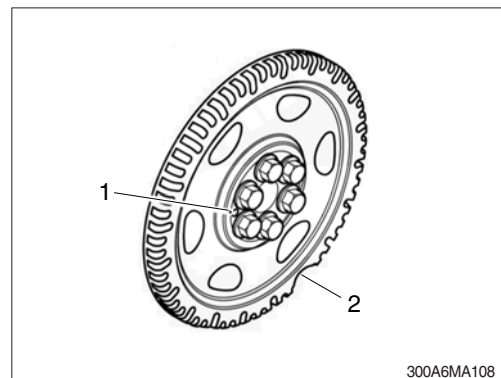

- (4) If both of the number 1 cylinder rocker levers are loose, proceed to the next step; If the number 1 cylinder rocker levers are not loose, rotate the crankshaft 360 degrees and proceed to the next step.



300A6MA109

- (5) Make sure to check the engine dataplate for correct valve lash (overhead set) specifications. The engine dataplate is typically located on the engine rocker lever cover, but may also be located on the left side of the gear housing.

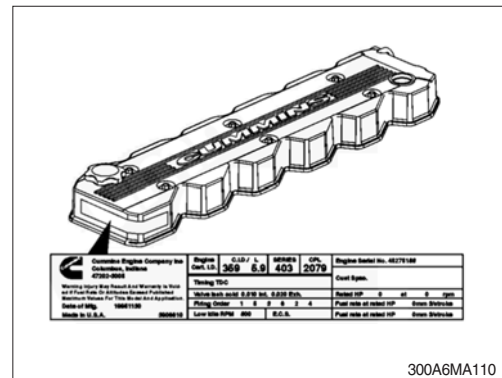

300A6MA110

- (6) If the number 1 cylinder is at TDC and both rocker levers are loose, the valve lash (overhead set) can be checked on the following rocker levers:
(E = exhaust, I = Intake)
1I, 1E, 2I, 3E, 4I, and 5E.

Overhead set check limits

Item		mm	inch
Intake	Min	0.152	0.006
	Max	0.381	0.015
Exhaust	Min	0.381	0.015
	Max	0.762	0.030

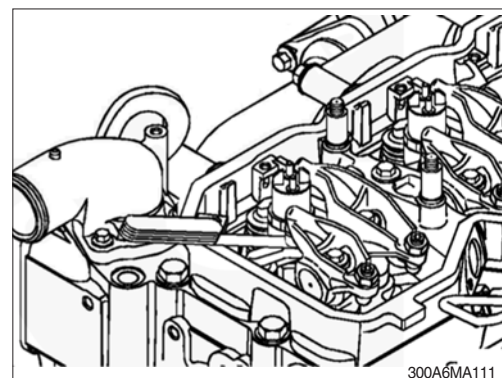

300A6MA111

- (7) Checking the overhead setting is usually performed as part of a troubleshooting procedure, and resetting is not required during checks, as long as the lash measurements are within the specifications shown above.

- (8) The clearance is correct when some resistance is felt when the feeler gauge is slipped between the crosshead and the rocker lever socket. Measure the valve lash (overhead set) by inserting a feeler gauge between the crosshead and the rocker lever socket. If the measurement is out of specification, loosen the locknut and adjust the lash to nominal specifications.

Overhead set valve lash

Item		mm	inch
Intake	Min	0.254	0.010
Exhaust	Max	0.508	0.020

- ※ **Tighten the lock nut and measure the clearance again.**

Tightening torque : 2.4 kgf·m (17.4 lbf·ft)

- (9) Use the barring tool, to rotate the crankshaft 360 degrees.
Use the previous steps and specifications to set the valve lash on the following rocker levers:
(E = exhaust, I = Intake)
2E, 3I, 4E, 5I, 6I, and 6E.

If the measurements are out of specification, set the valve lash.

- (10) Install the rocker lever cover gasket and cover, refer to engine maintenance manual.

- (11) Operate the engine. Check for leaks.

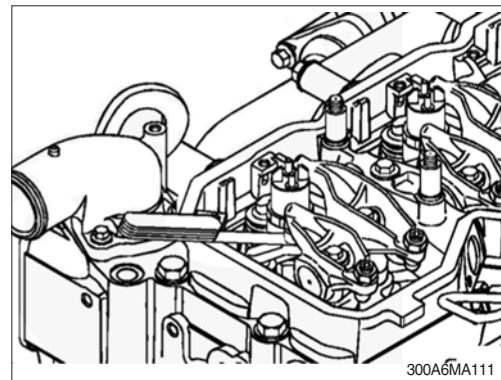
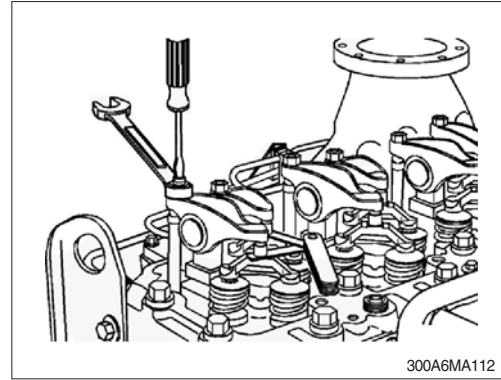

23) HYDRAULIC OIL CHECK

- (1) Lower the bucket on the ground at a flat location as in the illustration.
Stop the engine and then leave for about 5 minutes.
 - (2) Check the oil level at the level gauge. The level gauge is located on the left side of the hydraulic oil tank.
 - (3) The oil level is normal if between the red lines.
- ※ **Add hydraulic oil, If necessary.**

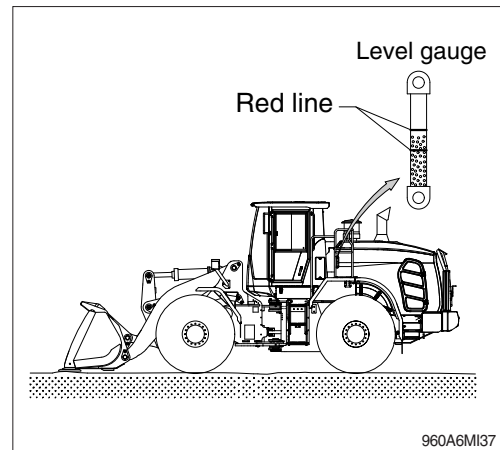

24) FILLING HYDRAULIC OIL

- (1) Stop the engine to the position of level check.
- (2) Rotate the cap nut counter-clockwise by hand and push the rod to release the air pressure.
- (3) Remove the breather on the top of oil tank and fill the oil to the specified level.
- (4) Start engine after filling and operate the work equipment several times.
- (5) Check the oil level at the level check position after engine stops.

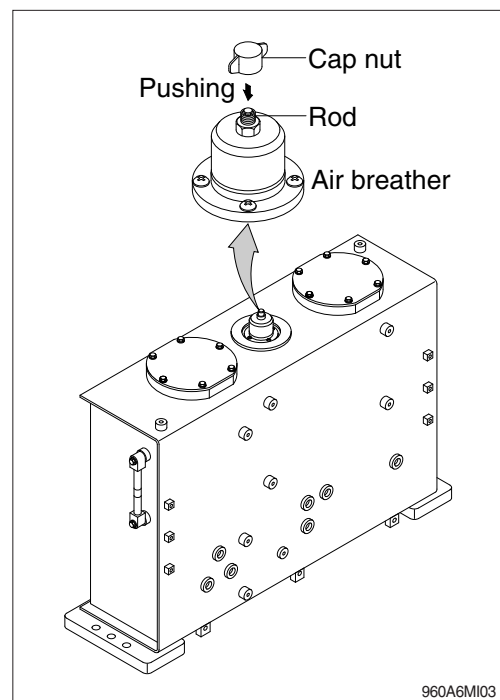

25) CHANGE THE HYDRAULIC OIL

- (1) Lower the bucket on the ground extend the bucket cylinder to the maximum.
- (2) Loosen the cap and relieve the pressure in the tank by pushing the top of the air breather.
- (3) Prepare a suitable container.
- (4) To drain the oil loosen the drain plug on the rear frame LH side.
- (5) Tighten the drain plug.
- (6) Fill proper amount of recommended oil.
- (7) Put the breather in the right position.
- (8) Start engine and run continually. Release the air by full stroke of control lever.

※ The oil must be free of bubbles. If bubbles are present in the oil, air is entering the hydraulic system. Inspect the suction hoses and hose clamps.

※ In case of injecting HBHO (Hyundai Bio Hydraulic Oil) to machines that have formerly used different hydraulic oil, the proportion of residual oil must not exceed 2 %.

※ Do not mix any other Bio oil, use only HBHO as bio oil.

If changing to Bio oil, contact HYUNDAI dealer.

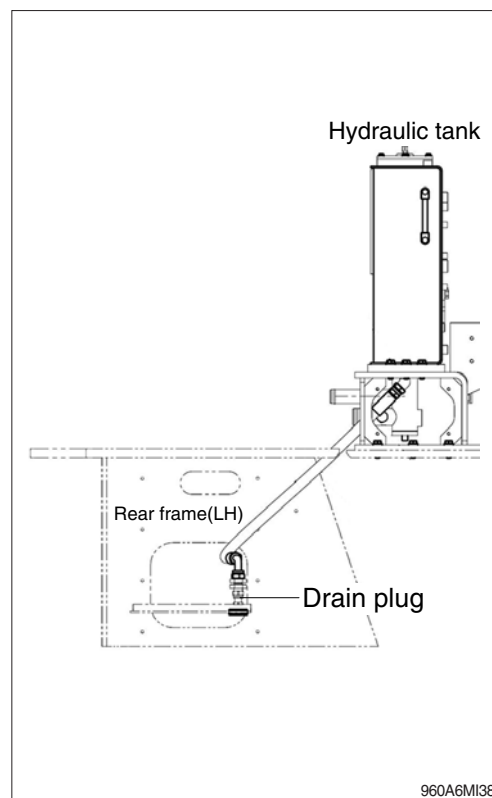

26) CLEANING AND REPLACING RETURN FILTER

Clean and replace the return filter in the following manner.

- (1) Remove the cover.
- (2) Remove spring, by-pass valve and return filter from the tank.
- (3) Replace element with new one and assemble spring and by-pass valve after cleaning.
- (4) Install the cover on the tank.

· Tightening torque : $6.9 \pm 1.4 \text{ kgf} \cdot \text{m}$
($50 \pm 10 \text{ lbf} \cdot \text{ft}$)

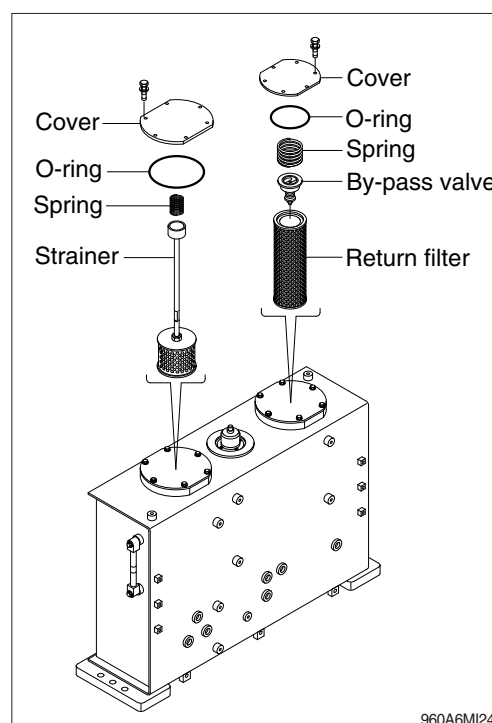

27) REPLACEMENT OF ELEMENT IN HYDRAULIC TANK BREATHER

- (1) Loosen the cap and relieve the pressure in the tank by pushing the top of the air breather.
- (2) Loosen the lock nut and remove the cover.
- (3) Pull out the filter element.
- (4) Replace the filter element new one.
- (5) Reassemble by reverse order of disassembly.
 - Tightening torque : $1.05 \pm 0.21 \text{ kgf} \cdot \text{m}$
($7.6 \pm 1.5 \text{ lbf} \cdot \text{ft}$)

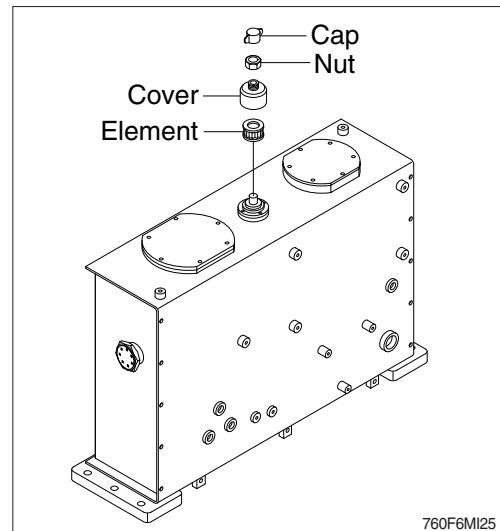

28) REPLACE OF PILOT LINE FILTER

- (1) Loosen the bowl positioned on the safety valve.
- (2) Pull out the filter element and clean the bowl.
- (3) Install the new element and tighten the bowl using spanner.
 - Spanner size : 27 mm

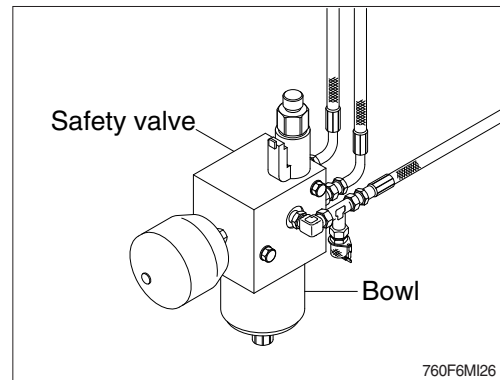

28-1) REPLACE OF PRESSURE FILTER

- (1) Loosen the pressure filter.
- (2) Install the new filter and tighten.

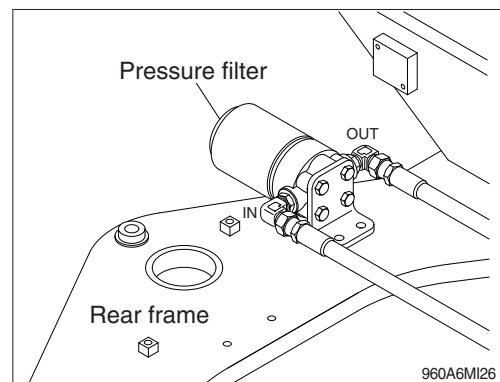

29) LUBRICATE RCV LEVER

Remove bellows and grease the joint (A) and the sliding parts (B).

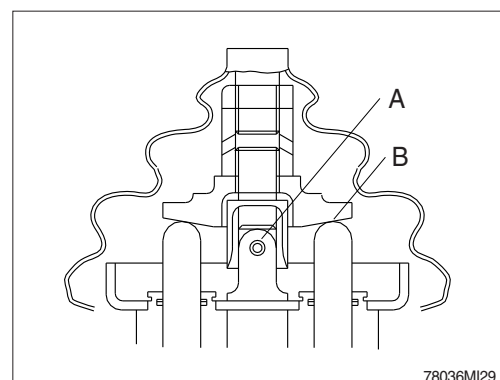

30) TIRE PRESSURE

- (1) Inappropriate tire pressure is a primary cause for tire damage. Insufficient tire pressure will damage internal carcass of tire. Repeated excessive bending will damage or break the carcass. Excessive pressure will also cause premature damage of tire.
- (2) Recommended tire pressure (When tire is cooled) / Refer to the page 5-1.

Size	Pressure
23.5 R25, ★(L3)	4.2 bar (60 psi)

- (3) Continuous operation will produce heat and increase pressure on tire. But such phenomenon was already taken into account when designing a tire. Do not try to remove normally increased air because tires may be crushed or overinflated.
- (4) The three major causes for excessive heat and pressure of tire are insufficient pressure, excessive load and overspeed. Avoid excessive load and overspeed in order to keep tires in good shape.

▲ Do not inflate tires using flammable gases or alcohol injector.

This cause explosion or personal injury.

▲ Inflate tires at the pressure level recommended by the manufacturer, and check periodically pressure and wear of tires.

▲ When replacing the inflated tire, do not stand near the tire.

※ Check the tire when the tire is at normal temperature and the machine is not loaded.

▲ Do not use recycled wheel parts.

▲ When removing lockering or inflating tire, use safety cable or chain to ensure safety.

※ Be sure to bleed air before removing lockering. Never inflate tires unless the lockering is assembled in its place.

- ① Avoid the followings when traveling.
- ② Rubbing tires against road bank or rack at cargo-unloading spot.
- ③ Tires slippage during working.
- ④ Abrupt starting of machine.

When oil, grease or gasoline smeared on tire, clean those. Otherwise it may cause of permanent deformation.

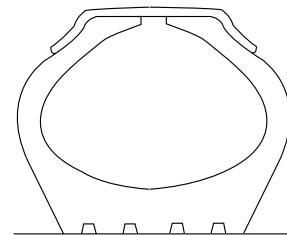

Normal

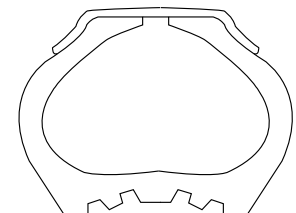

Too low pressure

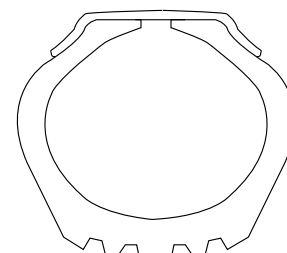

Excess pressure

31) REPLACEMENT OF TIRE

▲ Disassembly, reassembly, replacement and repair of tire requires special skills and equipment. Contact a tire repair shop.

(1) Tires to be replaced

- ① Tires with broken or bent bead wires
- ② Tires exposed more than 1/4 of carcass ply.
- ③ Tires whose carcass is damaged more than 1/3 of the tire width.
- ④ Tires which show ply separation.
- ⑤ Tires which has a radial crack near the carcass.
- ⑥ Tires which are judged to be unsuitable for use because of deformation or damage.

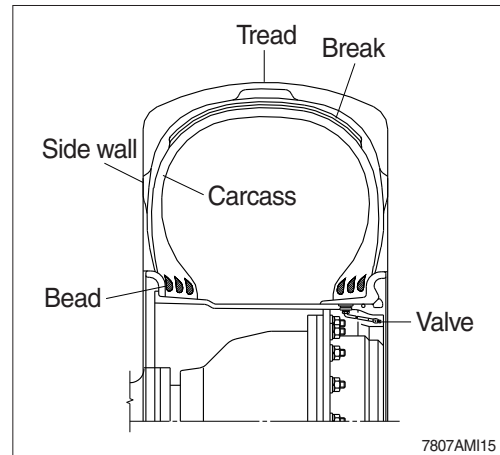

(2) Separation of tire

- ① After moving the machine to flat ground, lower the bucket to the ground and turn the parking brake switch ON.

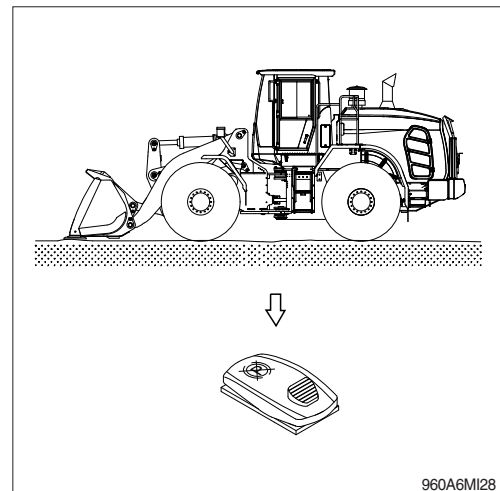

- ② Loosen slightly all wheel mounting.
 - Tools : Socket 32 mm
 - Torque wrench
 - Extension bar
- ③ Lift the machine with a jack.
- ④ Loosen all wheel mounting nuts and replace the tire.

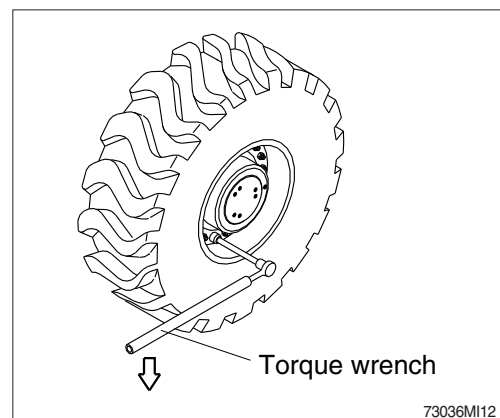

(3) Direction of tire to be installed

- ① Be careful that the valve should be facing the outside.

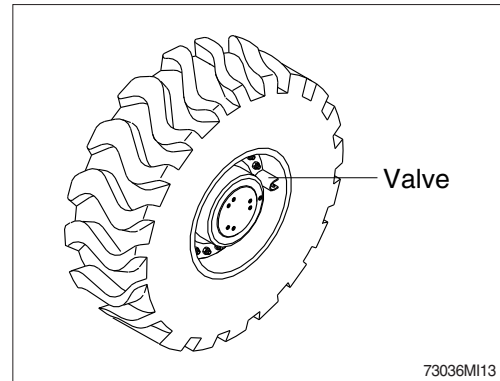

(4) Mounting of tire

- ① Lightly tighten nuts as shown in the illustration.
- ② Lower the jack after tire is replaced.
- ③ Tighten nuts according to the specified tighten torque.
 - Tightening torque : $79 \pm 2.5 \text{ kgf} \cdot \text{m}$
($571 \pm 18 \text{ lbf} \cdot \text{ft}$)

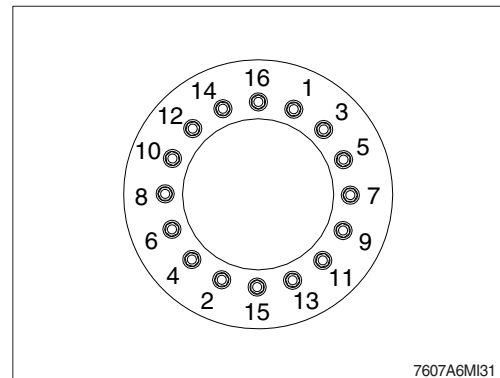

32) STORING TIRES AFTER REMOVAL

As a basic rule, store the tires in a warehouse which unauthorized persons cannot enter. If the tire are stored outside, always erect a fence around the tires and put up "No Entry" and other warning signs that even young children can understand.

Stand the tire on level ground, and block it securely so that it cannot roll or fall over.

If the tire should fall over, get out of the way quickly. The tires for construction equipment are extremely heavy, so trying to hold the tire may lead to serious injury.

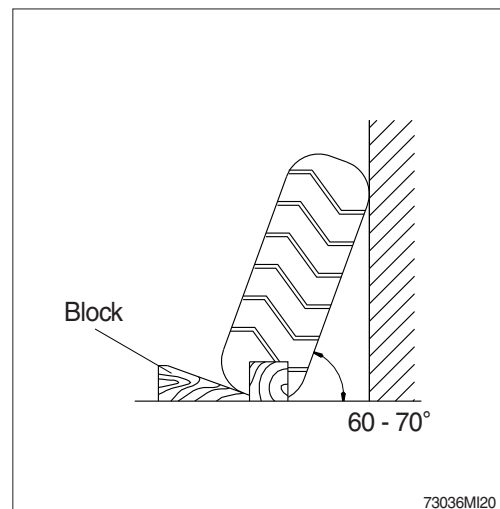

33) CHECK TRANSMISSION OIL LEVEL

- (1) The oil level check must be carried out as follows; oil level check (weekly).
- (2) Before the oil level check, Transmission must have been running to warm up enough.
- (3) When the oil level is checked, machine must be on flat ground and engine must be at idling speed, transmission must be in neutral position.
- (4) Check the oil level on level (sight) gauge.
- (5) Oil level
 - Operating temperature (about 80~90°C)
:The Oil level must be lying in zone HOT (between two red lines).
 - Cold phase (about 40°C)
:The Oil level must be lying near cold mark (blue line).

▲ When checking, press the parking brake switch and fix the front and rear frames with the safety lock bar.

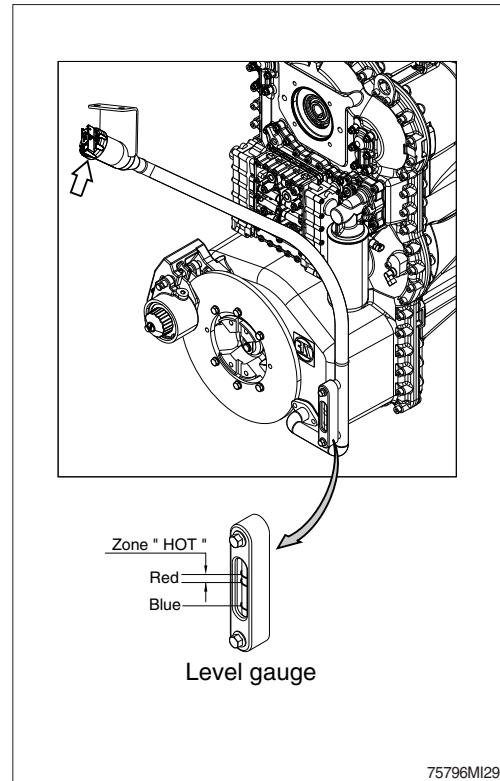

34) REPLACEMENT OF TRANSMISSION OIL AND FILTER ELEMENT

- (1) Operate the machine for a few minutes in order to warm the transmission oil.
- (2) Move the machine to flat ground. Lower the bucket to the ground and slightly apply downward force.
- (3) Press the parking brake switch and stop the engine.
- (4) Open transmission air breather to relieve internal air pressure.
- (5) Remove the transmission drain plug. Allow the transmission oil to drain into a suitable container.

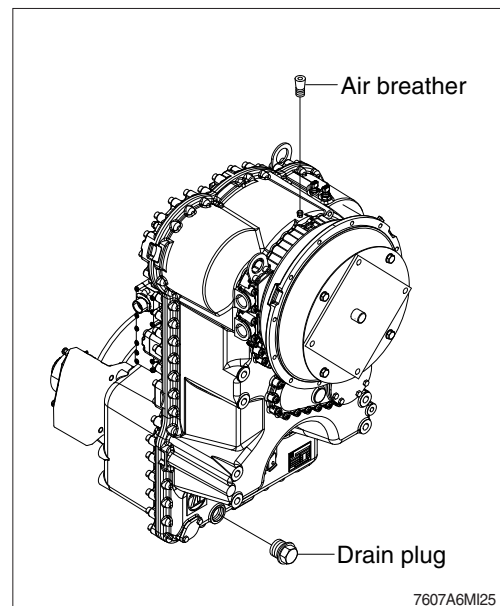

- (6) Remove the transmission oil filter cartridge.
Dispose of the used transmission oil filter cartridge properly.
- (7) Clean the filter cartridge mounting base.
Remove any part of the filter cartridge gasket that remains on the filter cartridge mounting base.

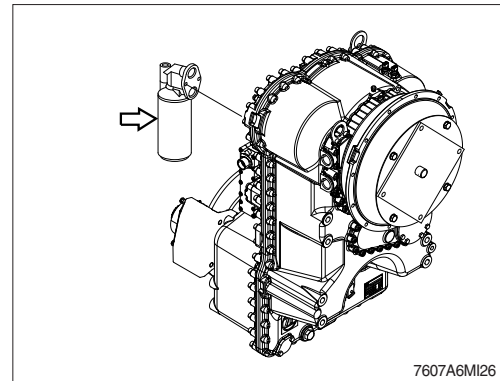

- (8) Apply a light coat of oil to the gasket of a new transmission oil filter cartridge.
- (9) Install the new transmission oil filter cartridge.
Screw the filter in until contacts with the sealing surface is obtained and tighten it now by hand about 1/3 to 1/2 turn.

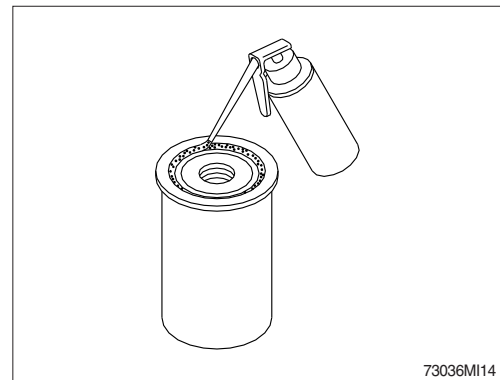

- (10) Fill the oil through filler cap and check if the oil is at the appropriate level.
- (11) The proper oil amount is 33 liters. (8.7 U.S. gallons)

- ▲ As the machine is hot after operation wait until the temperature has dropped.
- ▲ It is imperative to pay attention to absolute cleanliness of oil and filter.
Binding is in any case the marking on the oil level gauge.
- ※ Prohibition to inject water to filler cap directly when you wash the machine.

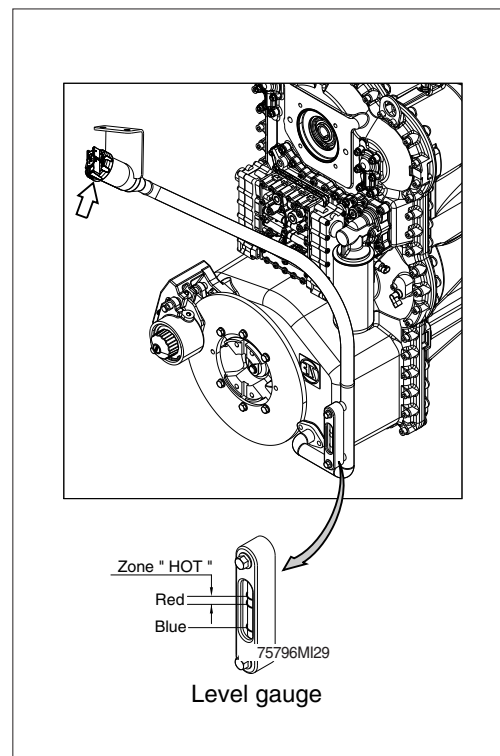

35) CLEANING TRANSMISSION AIR BREATHER

- (1) Remove dust or debris around the air breather.
- (2) Remove the air breather and wash it with cleaning oil.

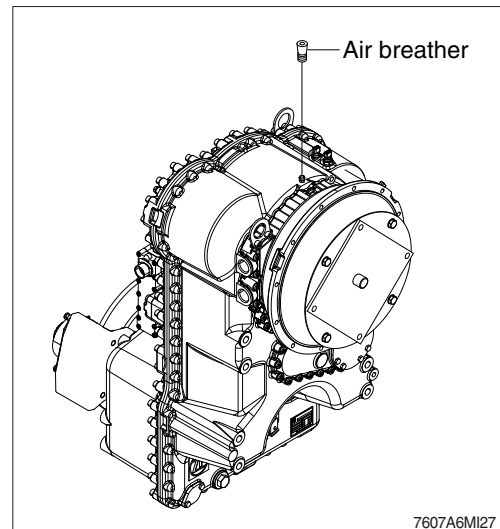

36) CHECK AND SUPPLYING AXLE OIL

- (1) Move the machine to flat ground.
- (2) Open the axle air breather to relieve internal air pressure.
- (3) Remove the plug and check the oil amount.
If the oil level is at the hole of the plug, it is normal.

※ Provide fill & level plug with O-ring and install it.

▲ When checking the oil level, press the parking brake switch and fix front and rear frames using the safety lock bar.

▲ As the machine is hot after operation, wait until the temperature has dropped.
Set the plug of planetary gear in parallel to the ground.

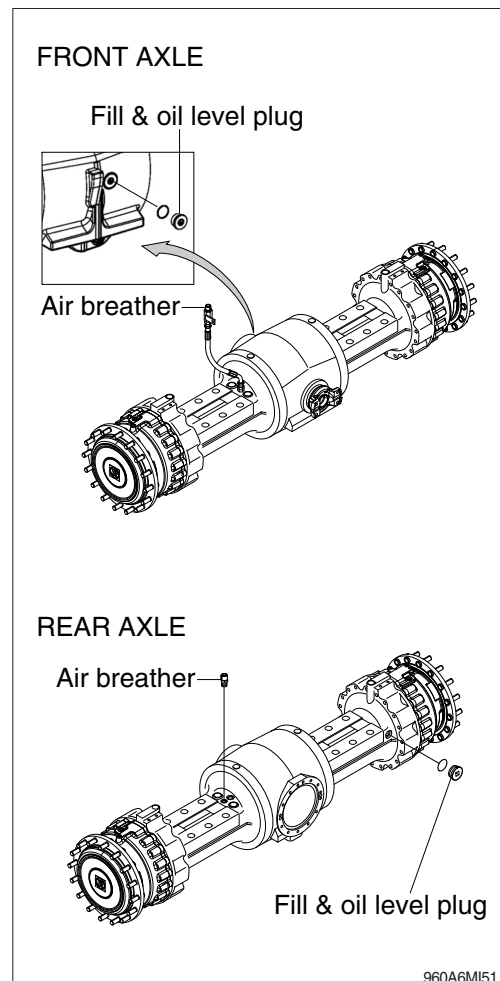

37) CHANGE THE AXLE OIL

- (1) Place a case under drain plug to catch oil.
- (2) Remove the air breather to relieve internal pressure.
- (3) The basic condition for a correct oil change of the axle is horizontal plane of installation in every direction.
Place machine in a horizontal position.
- (4) All plugs must be cleaned carefully before opening.
- (5) Loosen drain plugs and drain oil.
- (6) Provide drain plugs with new O-ring and install them.
- (7) Fill up oil to the overflow on fill & level plug.
 - Oil amount (HL960A, HL960A XT)
 - Front axle : 35 ℓ (9.2 U.S. gal)
 - Rear axle : 35 ℓ (9.2 U.S. gal)
 - Oil amount (HL960A HD, HL960A HD XT)
 - Front axle : 45 ℓ (11.9 U.S. gal)
 - Rear axle : 40 ℓ (10.6 U.S. gal)

- If equipped with axle oil coolers (option)

- (8) Replace front and rear axle oil filters.
- (9) Run the engine for five minutes at low idle on flat ground.
- (10) Fill up oil to the overflow on fill & level plug at low idle and install plugs.
 - Oil amount (HL960A, HL960A XT)
 - Front axle : 41 ℓ (axle only 35 ℓ)
 - Rear axle : 40 ℓ (axle only 40 ℓ)
 - Oil amount (HL960A HD, HL960A HD XT)
 - Front axle : 51 ℓ (axle only 45 ℓ)
 - Rear axle : 45 ℓ (axle only 40 ℓ)

▲ As the machine is hot after operation, wait until the temperature has dropped.

※ If a work requires frequent use of brake, replace it earlier than normal change interval.

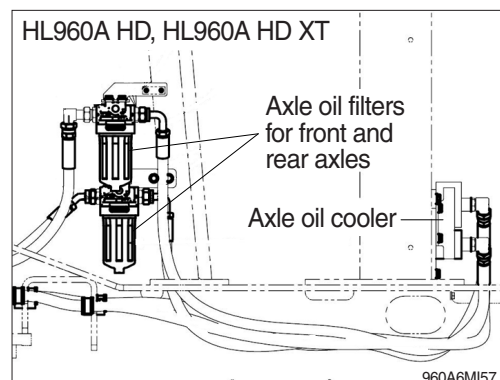
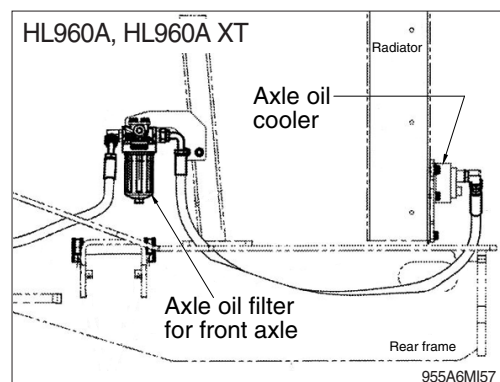
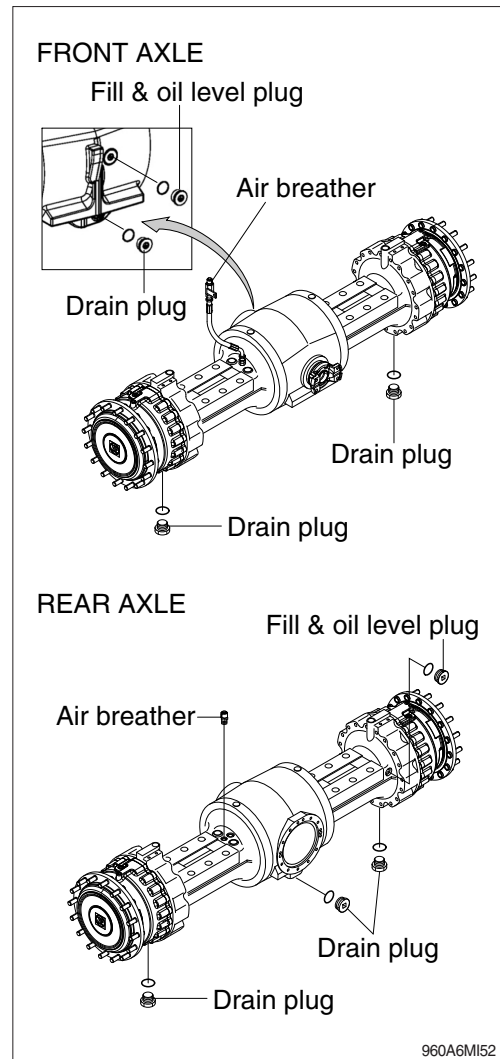

38) CLEANING AXLE BREATHER

- (1) Remove dust or debris around the breather.
- (2) Remove the breather and wash it with cleaning oil.

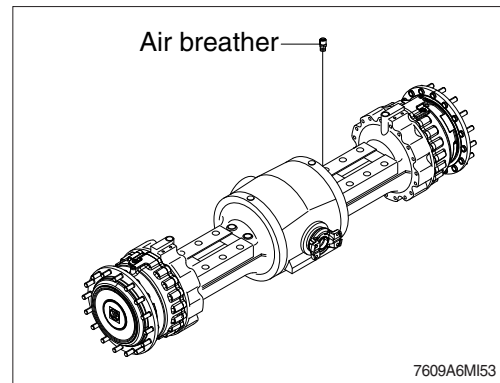

39) LUBRICATION

- (1) Supply grease through the grease nipple, using grease gun.
- (2) After lubricating, clean off spilled grease.

▲ Press the parking brake switch and fix front and rear frames using the safety lock bar.

▲ Set the work equipment in a stable position and push the pilot cut off switch to the OFF position.

- (3) Rear axle pivot : 2EA
- (4) Steering cylinder pin : 4EA

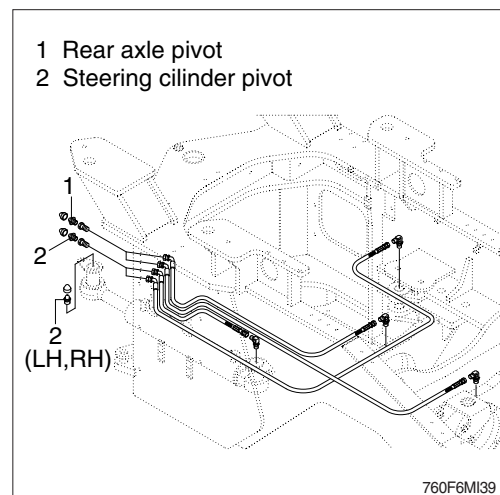

- (5) Center pivot pin : 2EA

(6) Drive shaft

- ① Front (flange bearing, journal bearing) : 2EA
- ② Center (sleeve yoke, journal bearing) : 4EA
- ③ Rear (sleeve yoke, journal bearing) : 3EA

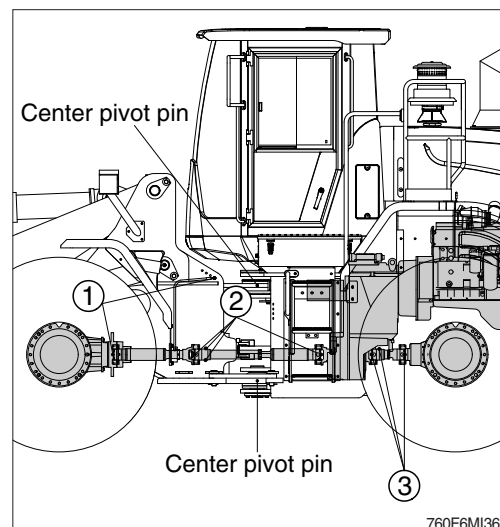

40) REPLACEMENT OF BOLT ON CUTTING EDGE

(1) Replacement time

Replace the cutting edge before it has worn out to the end of bucket.

(2) Replacement method

▲ Make sure the work equipment does not move when replacing the cutting edge.

Set the work equipment in a stable position, put the pilot cut off switch in the OFF position.

- ① Lift the bucket to a proper height and insert blocks so that the bucket does not fall down.
 - ② Loosen bolts and nuts, and remove the cutting edge.
 - ③ Clean the contacted surface.
 - ④ Turn the cutting edge and install on the bucket.
- ※ **If both sides have worn out, replace it with new ones.**
- ※ **If the contacted face of cutting edge has worn out, repair the contacted face of it.**
- ⑤ Tighten evenly bolts and nuts to remove the clearance between bucket and cutting edge.
 - Tightening torque : $83.2 \pm 12.5 \text{ kgf} \cdot \text{m}$
($60.2 \pm 90.4 \text{ lbf} \cdot \text{ft}$)
 - ⑥ After a few hours of operation, retighten bolts.

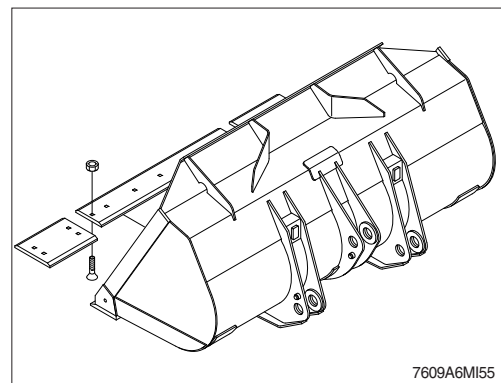
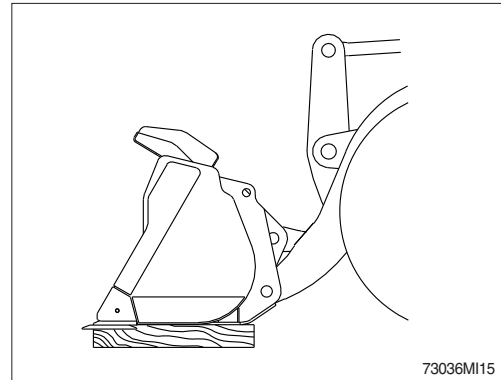

41) REPLACEMENT OF BUCKET TOOTH

(1) Replacement time

Replace the bucket tooth before it has worn out to the end of the bucket.

(2) Replacement method

▲ Make sure the work equipment does not move when replacing the bucket tooth.

Set the work equipment in a stable position, put the pilot cut off switch in the OFF position and stop the engine.

- ① Lift the bucket to a proper height and insert blocks so that the bucket does not fall down.
- ② Loosen bolts and nuts, and remove bucket tooth.
- ③ Clean the contacted surface.
- ※ **If the contacted face of bucket tooth has worn out, repair the contacted face of it.**
- ④ Install new bucket tooth on the bucket, and tighten bolts and nuts.
 - Tightening torque : $83.2 \pm 12.5 \text{ kgf} \cdot \text{m}$
($602 \pm 90.4 \text{ lbf} \cdot \text{ft}$)
- ⑤ After a few hours of operation, retighten bolts.

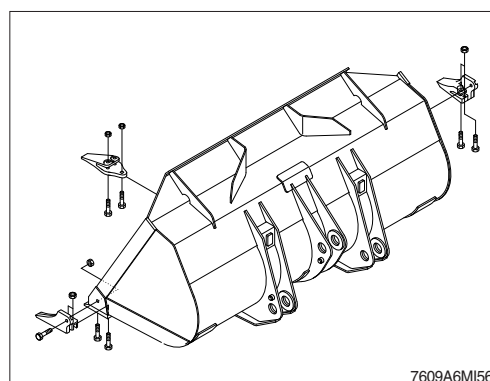
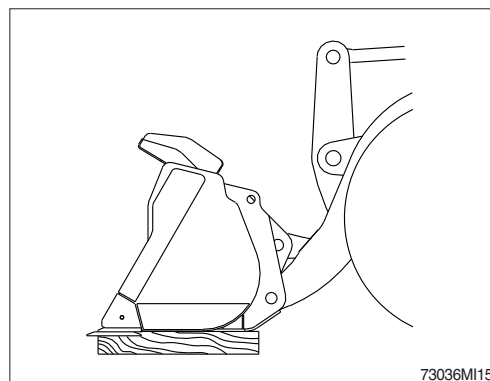

42) MAINTENANCE OF WORK EQUIPMENT

- (1) Lubricate to each pin of working device.
Lubricate the grease to grease nipple in accordance with lubrication intervals.

No.	Description	Qty
A	Bucket cylinder (front frame side) pin	1
B	Boom cylinder (front frame side) right pin	1
C	Boom-front frame right connection pin	1
D	Boom-front frame left connection pin	1
E	Boom cylinder (front frame side) left pin	1
F	Boom cylinder-boom connection pin	2
G	Bucket cylinder-bell crank connection pin	1
H	Boom-bell crank connection pin	1
I	Bell crank-bucket link connection pin	1
J	Bucket-Bucket link connection pin	2
K	Bucket-boom connection pin	2

※ Shorten lubricating interval when working in the water or dusty place.

- (2) Check for wear and tear of work equipment pins and bushings.
(3) Check for damage of boom and bell crank.

- (4) Dust seal are mounted on the rotating part of working device to extend the lubricating interval.
- ※ Mount the lip to be faced out side when replace the dust seal.
 - ※ If it is assembled in wrong direction, it will cause fast wear of pin and bushing, and create noise and vibration during operation.
 - ※ Make sure the seals are not damaged or deformed.

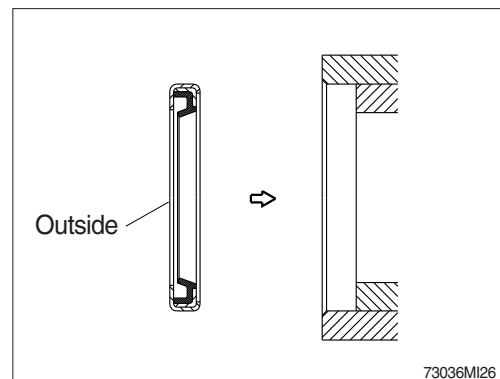
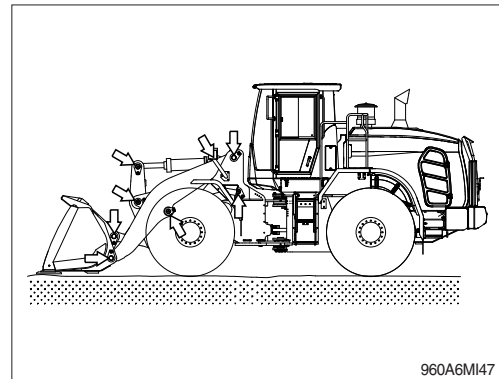
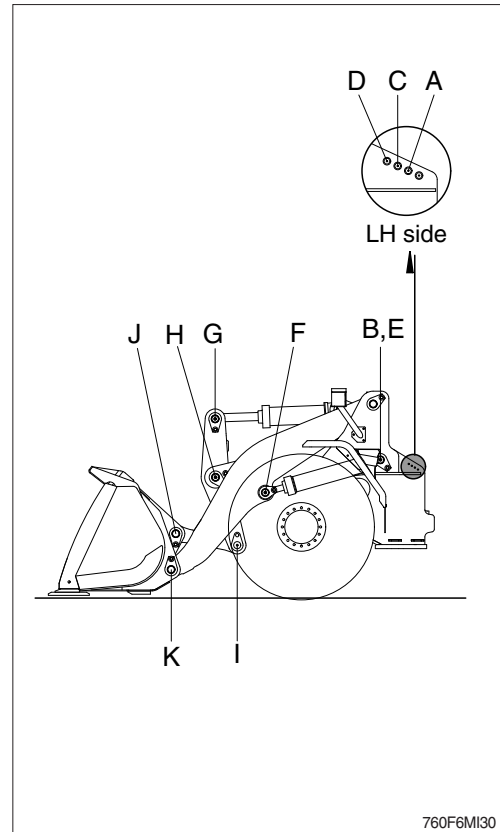

43) WORK EQUIPMENT SUPPORT

When carrying out inspection and maintenance with the equipment raised, fit a stand under the lift arm securely to prevent the work equipment from coming down. In addition, set the work equipment control levers to the Hold position and put the pilot cut off switch to the OFF position.

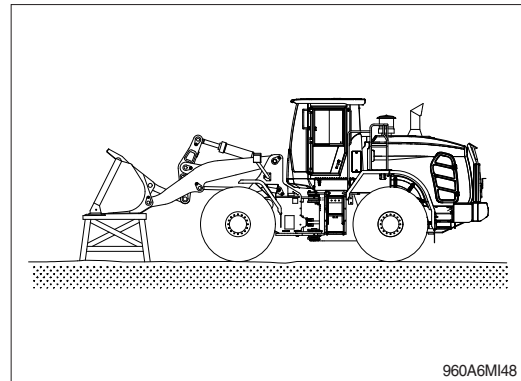

44) BOOM SAFETY LOCK BAR (option)

(1) Supporting

▲ If it is necessary to carry out any maintenance operation or to stop the machine with raised boom, always use the boom safety lock bar and put the pilot cut off switch to the OFF position.

※ The attachment should be empty.

- ① Raise the boom fully.
 - ② Stop the engine and remove the starter key.
 - ③ Loosen the two wing bolts and remove safety lock bar from its stowage position.
 - ④ Place the safety lock bar onto the boom cylinder and secure the safety lock bar by tying the string shown as figure.
 - ⑤ Slowly lower the boom to fix the safety lock bar.
- ※ When lowering the boom, operate the control lever very slowly.

(2) Lowering

- ① Raise the boom to take the weight off the safety lock bar.
- ② Stop the engine and remove the starter key.
- ③ Loosen the string and remove the safety lock bar carefully.
- ④ Reinstall the safety lock bar onto its stowage position using the wing bolts.

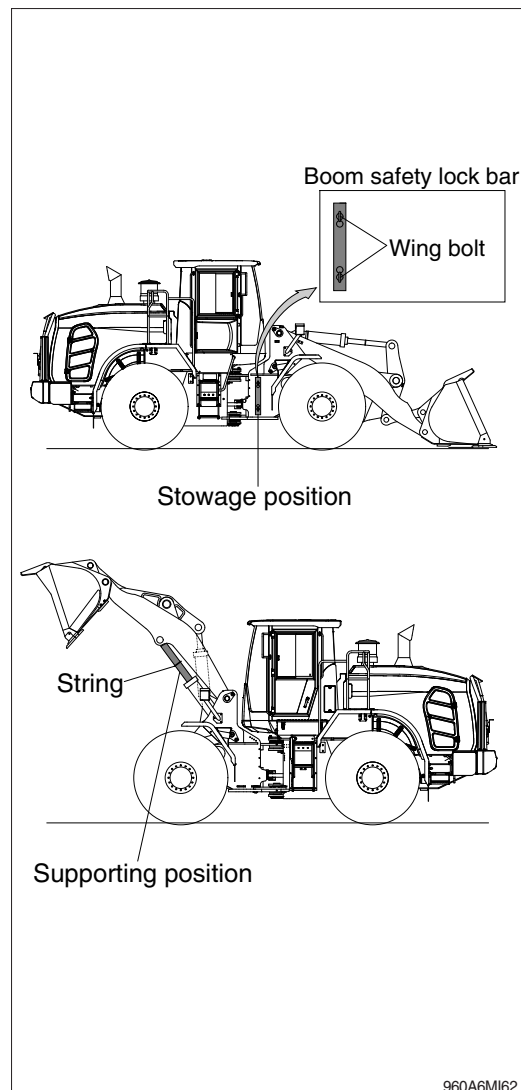

7. ELECTRICAL SYSTEM

1) WIRING, GAUGES

Check regularly and repair loose or malfunctioning gauges when found.

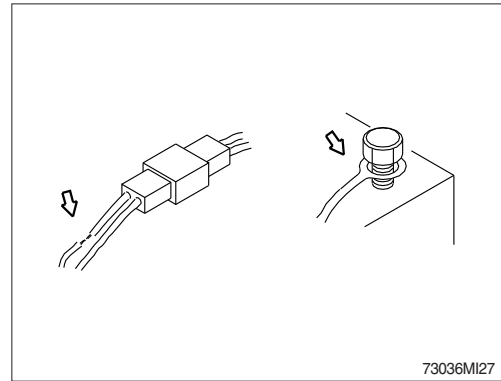

2) BATTERY

(1) Clean

- ① Wash the terminal with hot water if it is contaminated, and apply grease to the terminals after washing.
- ⚠ **Battery gas can explode. Keep sparks and flames away from batteries.**
- ⚠ **Always wear protective glasses when working with batteries.**
- ⚠ **Do not stain clothes or skin with electrolyte as it is acid.**
Be careful not to get the electrolyte in eyes.
Wash with clean water and go to the doctor if it enters the eyes.
- ⚠ **Avoid short-circuiting the battery terminals through accidental contact with metallic objects, such as tools, across the terminals.**
- ⚠ **Do not store tools, bucket tooth and other flammable things in battery box. They could cause a fire.**
- ⚠ **Tighten the battery terminals securely.**
Loosened terminals can generate sparks and lead to explosion.
- ⚠ **Make sure that the battery terminal's caps always are installed.**

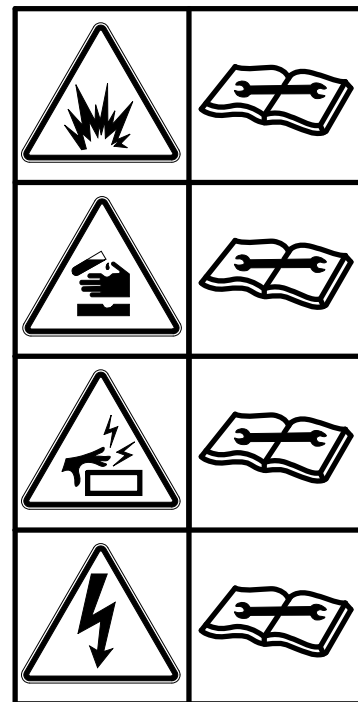

7579A0FW30

(2) Recycle

Never discard a battery.

Always return used batteries to one of the following locations.

- A battery supplier
- An authorized battery collection facility
- Recycling facility

(3) Method of removing the battery cable

Remove the cable from the ground connection first (⊖ terminal side) and reconnect it last when reassembling.

※ Pay attention to the correct polarity.

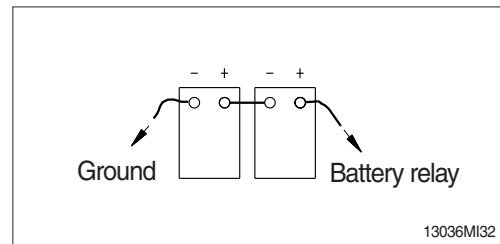

3) STARTING THE ENGINE WITH A BOOSTER CABLE

Keep following order when you are going to start engine using booster cable.

(1) Connection of booster cable

※ Use the same capacity of battery for starting

- ① Connect the red terminal of booster cable to the battery(+) terminal between exhausted and new battery.
- ② Connect the black terminal of the booster cable to the battery (-) terminal between exhausted and new battery.

※ Keep firmly all connection, the spark will be caused when connecting finally.

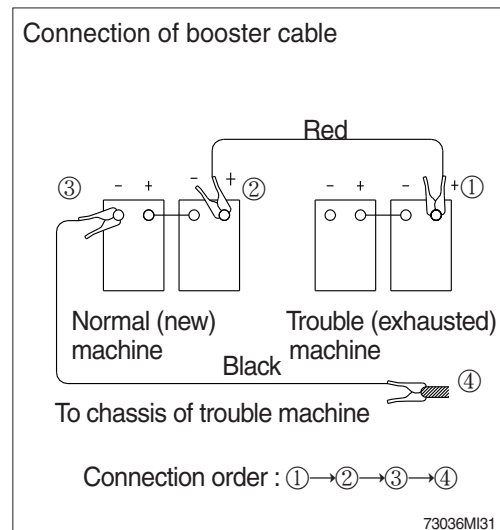

(2) Starting the engine

- ① Start engine with starting key.
- ② If you can not start it by one time, restart the engine after 2 minutes.

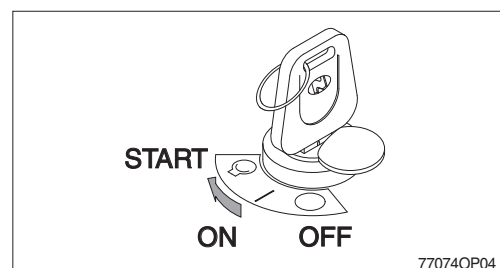

(3) Taking off the booster cable

- ① Take off the booster cable (black).
- ② Take off the booster cable (red) connected to the (+) terminal.
- ③ Run engine with high idle until charging the exhausted battery by alternator, fully.

▲ Explosive gas is generated while using the battery or charging it. Keep away flame and be careful not to cause the spark.

※ Charge the battery in the well ventilated place.

※ Place the machine on the earth or concrete. Avoid to charge the machine on the steel plate.

※ Do not connect (+) terminal and (-) terminal when connecting booster cable because it will be shorted.

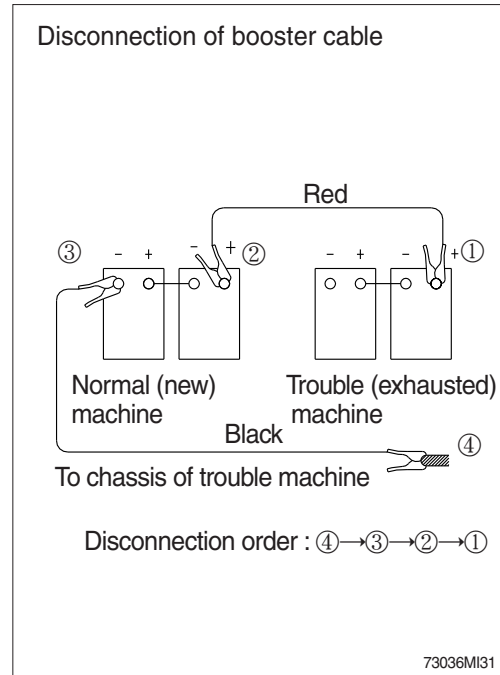

4) Welding repair

Before start to welding, follow the below procedure.

- (1) Shut off the engine and remove the starting switch.
- (2) Disconnect ground cable from battery by master switch.
- (3) Before carrying out any electric welding on the machine, the battery cables should be disconnected and the connectors pulled out of the electronic control units (MCU, TCU, ECU, EHCU, cluster, monitor etc).
- (4) Connect the earth (ground) lead of the welding equipment as close to the welding points as possible.

※ Do not weld or flame cut on pipes or tubes that contain flammable fluids. Clean them thoroughly with nonflammable solvent before welding or flame cutting on them.

▲ Do not attempt to welding work before carry out the above.

If not, it will caused serious damage at electric system.

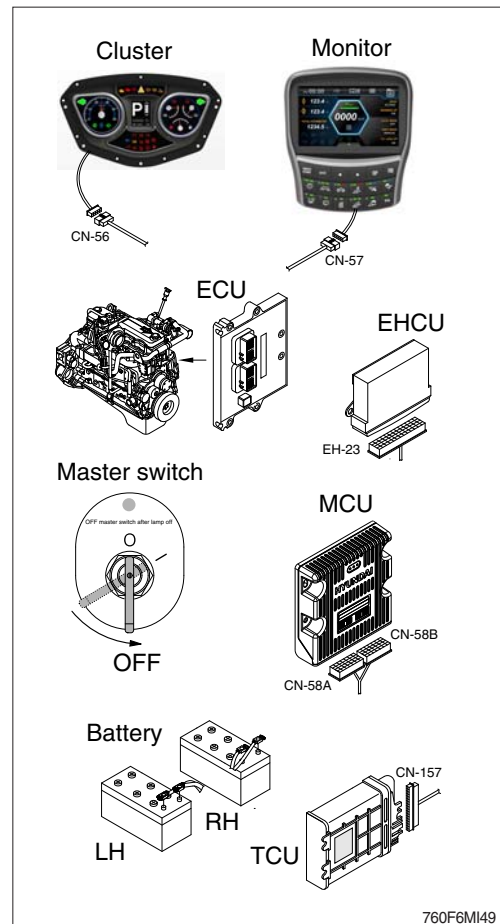

8. AIR CONDITIONER AND HEATER

1) CLEAN AND REPLACE OF INNER AND OUTER FILTER

※ Always stop the engine before servicing.

- (1) Open the air conditioner cover, loosen the wing bolt and remove the inner and outer filter.
- (2) Clean the filter using a pressurized air (below 2 kgf/cm², 28 psi).
- △ When using pressurized air, be sure to safety glasses.
- (3) Inspect the filter after cleaning. If it is damaged or badly contaminated, use a new filter.

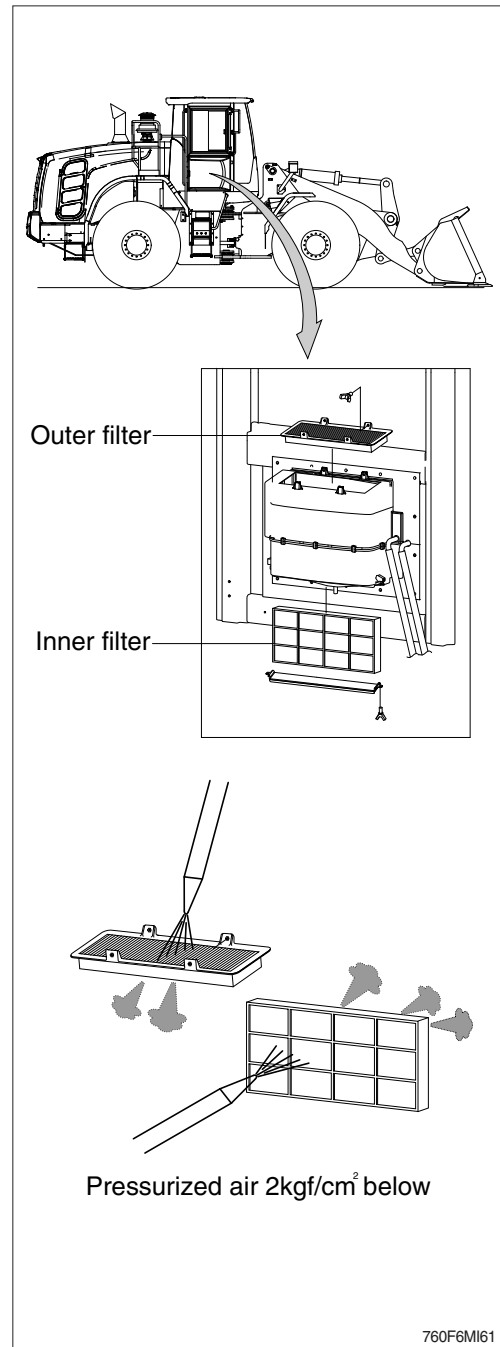

2) PRECAUTIONS FOR USING AIR CONDITIONER

- (1) When using the air conditioner for a long time, open the window once every one hour.
- (2) Be careful not to overcool the cab.
- (3) The cab is properly cooled if the operator feels cool when entering there from outside (about 5°C lower than the outside temperature).
- (4) When cooling, change air occasionally.

3) CHECK DURING SEASON

Ask the service center for replenishment of refrigerant or other maintenance service so that the cooling performance is not damaged.

4) CHECK DURING OFF-SEASON

Operate the air conditioner 2 or 3 times a month (each for a few minutes) to avoid loss of oil film in the compressor.

5) REFRIGERANT

(1) Equipment contains fluorinated greenhouse gas.

Model	Type	Total mass	GWP :1430
HL960A	HFC-134a	0.75 kg (1.65 lb)	1.07t CO ₂ eq.

※ GWP

Global warming potential (GWP) is a measure of how much heat a gas traps in the atmosphere relative to that of carbon dioxide (CO₂). GWP is calculated in terms of the 100-year warming potential of 1 kg of a greenhouse gas relative to 1 kg of CO₂.

(2) Environmental precautions

The air conditioning system of the machine is filled with HFC-134a refrigerant at the factory. HFC-134a refrigerant is a fluorinated greenhouse gas and contributes to global warming. Do not release refrigerant into the environment.

(3) Safety precautions

Work on the air conditioning system must only be performed by a qualified service technician. Do not attempt to perform work on the air conditioning system. Wear safety goggles, chemical resistant gloves and appropriate personal protective equipment to protect bare skin when there is a risk of contact with refrigerant.

(4) Action in case of exposure

- ① Eye contact / Limited skin contact
Rinse with warm water and apply a light bandage. Seek medical attention immediately.
- ② Extensive skin contact
Rinse with warm water and carefully heat the area with warm water or warm clothing.
Seek medical attention immediately.
- ③ Inhalation
Leave the area and find fresh air. Seek medical attention immediately.

7. TROUBLESHOOTING GUIDE

1. ENGINE

※ This guide is not intended to cover every conditions, however many of the more common possibilities are listed.

Trouble	Service	Remark
Engine oil pressure lamp fails to go off immediately after the engine is started.	<ul style="list-style-type: none"> · Add the oil to the specified level. · Replace the oil filter. · Check oil leakage from the tube or the joint. 	
Steam is emitted from the top part of the radiator (The pressure valve). Engine coolant temperature gauge indicates red range.	<ul style="list-style-type: none"> · Supply the cooling water and check leakage. · Adjust fan belt tension. · Wash out inside of cooling system. · Clean or repair the radiator fin. · Check the thermostat. · Check the engine coolant temperature gauge. · Tighten the radiator cap firmly or replace the gasket of it. 	
Engine does not start when the starting motor is turned over.	<ul style="list-style-type: none"> · Add fuel · Repair where air is inhaled into fuel system. · Check the injection pump or the nozzle. · In cold weather, check if fuel warmer system is working normal. · Check the valve clearance. 	Refer to the pages 4-5.
Exhaust gas is white or blue.	<ul style="list-style-type: none"> · Adjust to specified oil quantity. · Replace with specified fuel. 	
Exhaust gas occasionally turns black.	<ul style="list-style-type: none"> · Clean or replace the air cleaner element. · Check the nozzle. · Check engine compression pressure. · Check or replace the turbocharger. 	
Combustion noise occasionally changes to breathing sound.	<ul style="list-style-type: none"> · Check the nozzle. · Check the injection pump. 	
Unusual combustion noise or mechanical noise.	<ul style="list-style-type: none"> · Check with specified fuel. · Check overheating. · Check the muffler. · Adjust valve clearance. 	

2. ELECTRICAL SYSTEM

Trouble	Service	Remark
Voltmeter fluctuates largely even with the engine running at a constant speed. Lamp does not glow brightly even when engine runs at high speed. Lamp flickers while engine runs.	<ul style="list-style-type: none"> · Check for loose terminals open-circuit wiring. · Adjust belt tension. 	
Voltmeter does not fluctuate even with an increase in the engine speed.	<ul style="list-style-type: none"> · Check the alternator. · Inspect and repair wiring. 	
Starting motor does not turn when starting switch is turned on.	<ul style="list-style-type: none"> · Inspect and repair the wiring. · Charge the battery. · Check starting switch. · Check battery relay switch. · Place the gear selector lever in the neutral. 	
Starting motor turns the engine sluggishly.	<ul style="list-style-type: none"> · Charge the battery. · Check the starting motor. 	
Starting motor disengages before the engine starts up.	<ul style="list-style-type: none"> · Check and repair the wiring. · Charge the battery. 	
Engine oil pressure lamp does not light up when engine is stationary (When the starting switch is in ON position).	<ul style="list-style-type: none"> · Check the lamp. · Check the oil pressure switch. 	
Charge lamp does not light up when the engine is stationary. (When the starting switch is in ON position.)	<ul style="list-style-type: none"> · Check the lamp. · Check and repair the wiring. 	

3. POWER TRAIN SYSTEM

Trouble	Service	Remark
Engine is running but machine will not move.	<ul style="list-style-type: none"> · Release parking brake. · Put gear selector lever in position properly. · Add oil to transmission case to the specified level. 	
Even at full throttle, machine moves slowly and lacks power.	<ul style="list-style-type: none"> · Add oil to transmission case to the specified level. · Disassemble transmission strainer and clean. 	
Transmission oil overheats.	<ul style="list-style-type: none"> · Add oil to transmission case to the specified level or drain oil. · Use a suitable gear speed. · Reduce time using torque converter at stall speed. Check engine. 	
Abnormal noise is produced.	<ul style="list-style-type: none"> · Add oil to transmission case to the specified level. · Add oil to axle case to the specified level. 	
Brake does not work when pedal is depressed.	<ul style="list-style-type: none"> · Raise hydraulic oil pressure to specified level. · Add brake oil. · Bleed hydraulic oil from brake system. 	
Brake drags or stay when applied.	<ul style="list-style-type: none"> · Clean breather and bleed air from brake system. 	
Brake slips.	<ul style="list-style-type: none"> · Raise hydraulic oil pressure to the specified level. 	
Brake does not work properly.	<ul style="list-style-type: none"> · Adjust linkage. · Clean brake pad. · Replace spring in hydraulic oil cylinder. · Adjust or replace brake pad. 	
Steering wheel is heavy.	<ul style="list-style-type: none"> · Repair or replace the pump. · Repair, clean and reset the relief valve. · Coat a grease to connections and bearings of steering gear. · Check the mounting of the steering column. 	
Steering wheel turning by itself.	<ul style="list-style-type: none"> · Replace leaf springs. 	
Slow steering.	<ul style="list-style-type: none"> · Clean spool and sleeve. · Replace leaf springs. 	
Impossible to turn the steering wheel into neutral position.	<ul style="list-style-type: none"> · Check the monitor. · Check and repair the wiring. 	

4. HYDRAULIC SYSTEM

Trouble	Service	Remark
Bucket lacks lifting power. Bucket lifting speed is slow.	<ul style="list-style-type: none">· Check the hydraulic oil level and add if necessary.· Replace filter in hydraulic tank.	
Bubbles in oil.	<ul style="list-style-type: none">· Replace with specified oil.· Add oil if needed.	
Oil pressure is too low.	<ul style="list-style-type: none">· Bleed air from oil line.· Add oil and bleed air.	
Cylinder vibrates when operating.	<ul style="list-style-type: none">· Add oil.	

1. CENTRAL GREASE LUBRICATION SYSTEM

1) MAJOR COMPONENT

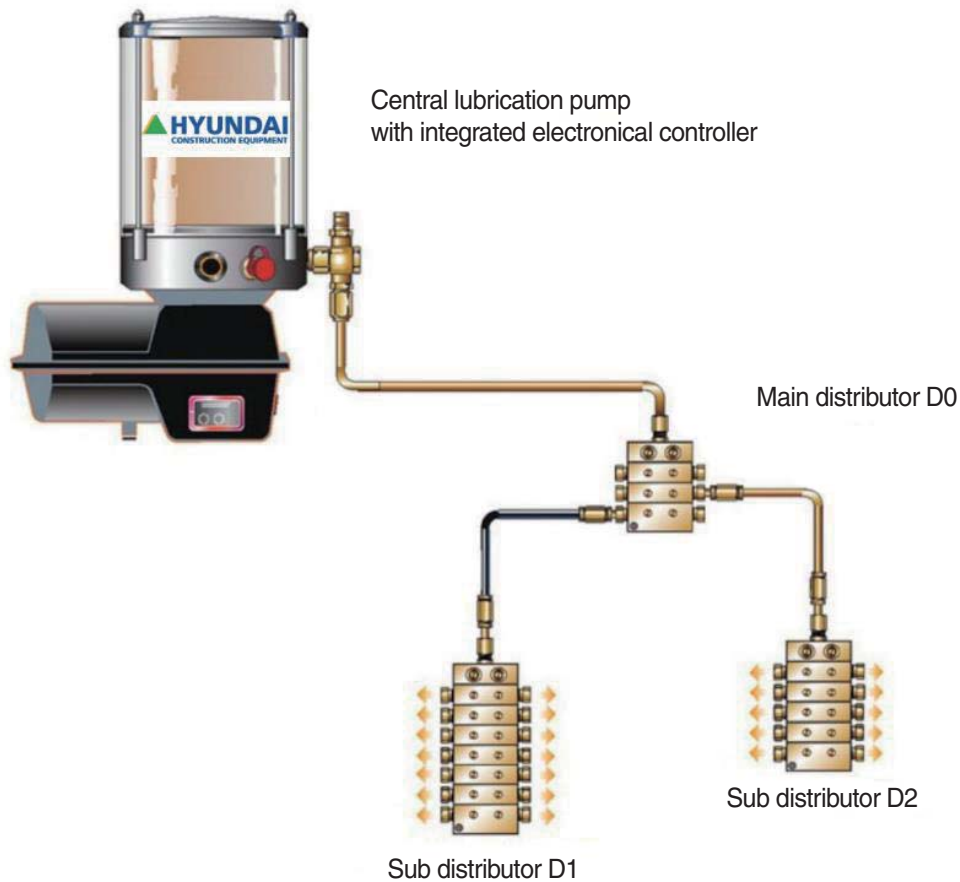

The progressive system supplies the lubrication points in a fixed order.

The progressive distributor works consecutively (progressive). Only after the first lube point has received the right lubricant quantity, the distributor continues running and delivers the next one.

The progressive system can be monitored easily and offers various extension possibilities.

The distributors distinguish themselves by modular flexibility instead of rigid block design.

2) LAYOUT

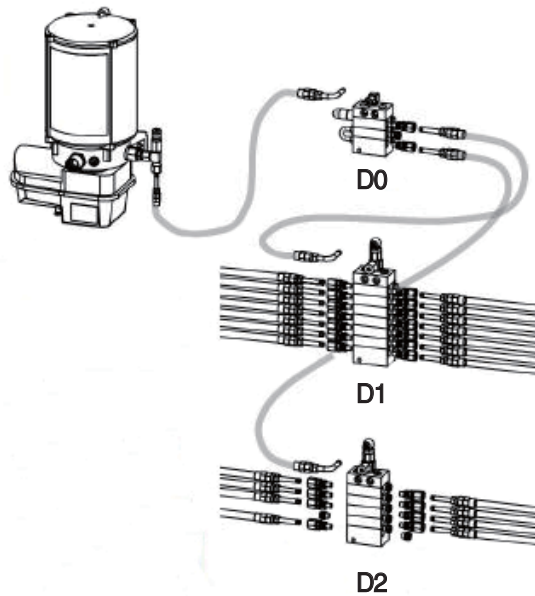
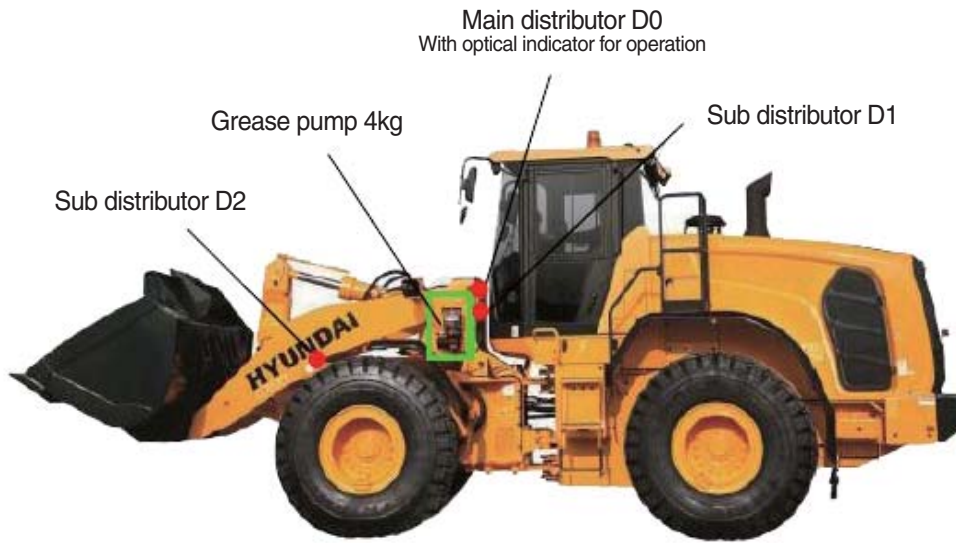

※ Refer to the CENTRAL GREASE LUB SYSTEM of parts manual for detail.

3) SWITCH

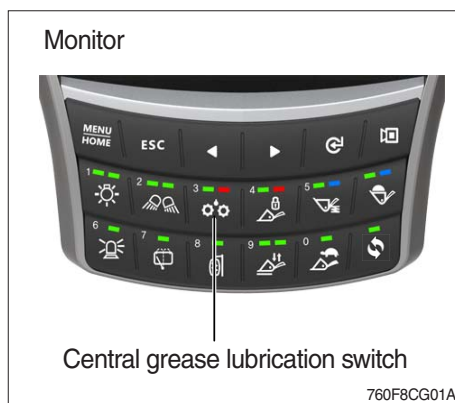

(1) The switch is integrated in monitor.

In the cab, a operator can reset and check the lubrication system.

※ Refer to page 3-40.

4) GREASE PUMP



Operating voltage	24 V/DC
Maximum operating pressure	280 bar
Permissible operating temperature (depending on the grease type)	-35°C to +70°C
Reservoir size	4 kg

Pump element is drawing in :

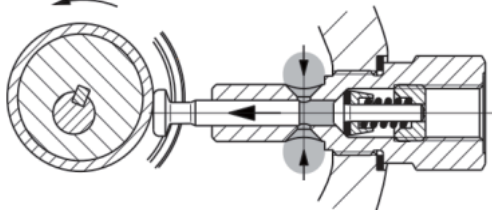

Pump element is delivering :

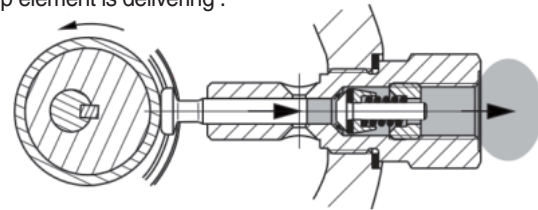

(1) Desmodromic actuation of the pumping elements

The pumping elements are not driven by a simple return spring but have a desmodromic push-pull actuation. This guarantees a reliable functioning of the pump even by the use of rigid grease (up to NLGI 2) and very low ambient temperatures.

5) INTEGRATED ELECTRONICAL CONTROLLER

When the central lubrication processor is time controlled, the cycle duration and the lubrication time can be adjusted. Cycle duration means the period from the beginning of one lubrication process to the beginning of another lubrication process.

Diagram of cycle sequence :

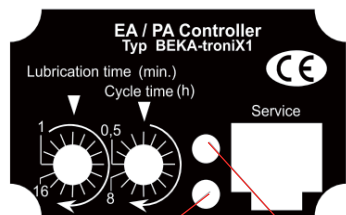

Red LED showing faults
Green LED showing function

Diagram of cycle sequence :

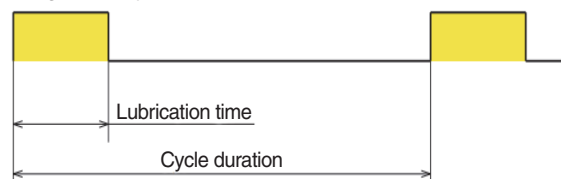

(1) Adjusting the parameters

The lubrication time can be set by means of graduating switches in the controller's sight glass. To adjust the time setting, remove the red frame on the pump's motor housing using a flat screwdriver, loosen the four screws and remove the transparent protective cover. The lubrication time can be adjusted using a flat screwdriver. If the cover plate is not replaced properly, water may enter the controller and damage it. In this case, the guarantee is no longer valid.

Lubrication times	Cycle duration
1 to 16 minutes (16 grades every 1 minute)	0.5 to 8 hours (16 grades every 0.5 hours)

(2) Summary of signal Indicators

The pump's function are indicated via two control LEDs (green/red) in the display on the pump's motor casing, where the red LED always indicates an error in the program sequence. These control LED functions may be indicated in the cab via monitor.

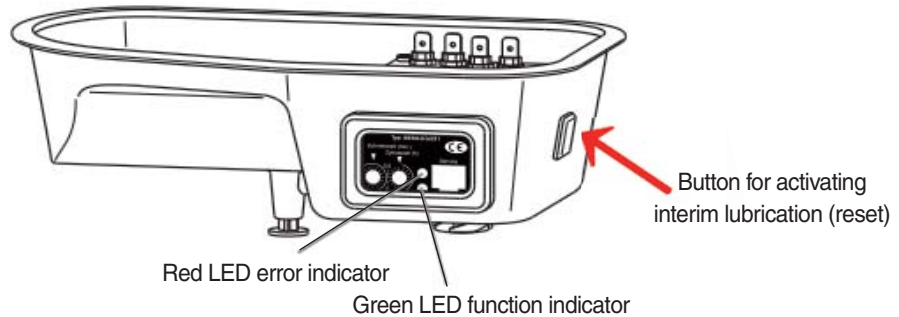

① Standby

Standby indicator :

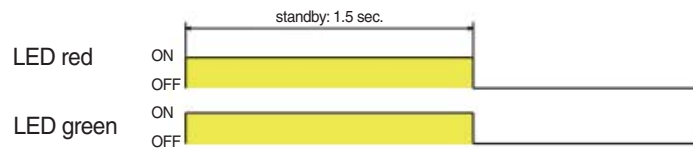

② Lubrication activated

Lubrication sequence :

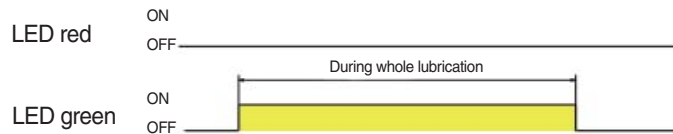

③ Revolution and engine driver error

Revolution error in pump engine

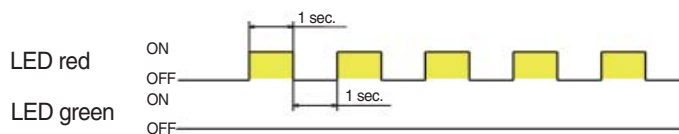

④ Memory error

Memory error :

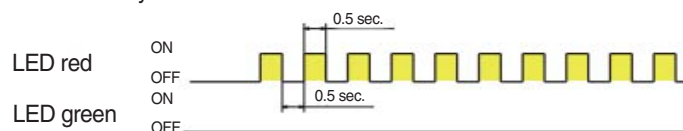

6) DISTRIBUTOR

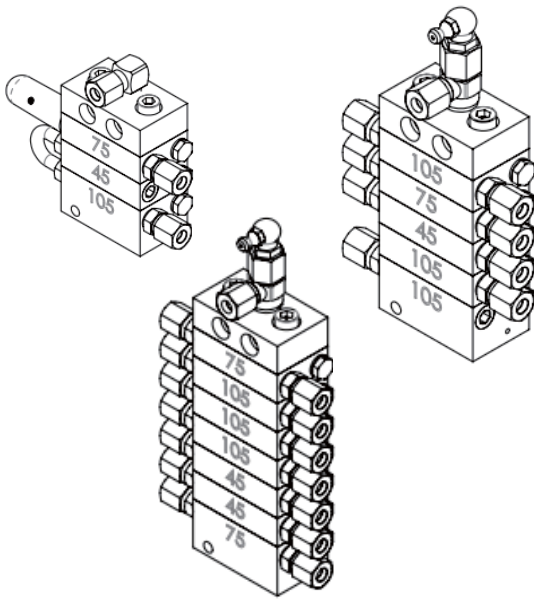

Operating pressure-Inlet	Temperature range
maximum 300 bar	-35°C to +80°C

- Modular designed distributor system for optimum lubricant feed rates
- Flexible extension possibilities
- Highest precision
- Comprehensive program of distributor types
- Optionally with monitoring and blockade control
Optimized distributor combination through field test at HCE durability test site

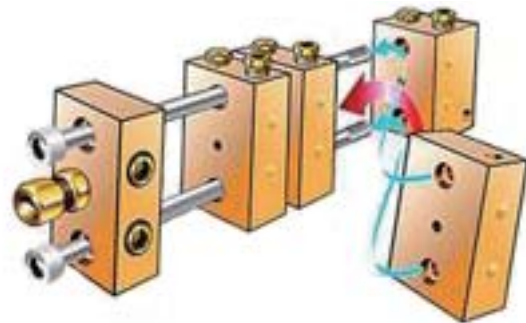

7) INSTRUCTIONS FOR REPAIR IN CASE OF BLOCKAGE OF A PROGRESSIVE LUBRICATION SYSTEM

(1) Reason of system blockage

- A creased or clogged lubrication pipe
- A bearing overfilled or clogged by lubricant
- Lubricant not suitable for central lubrication system
- Distributor outlet closed
- Blocked distributor

(2) Message signaling a blockade

If the system pressure should exceed the rated service pressure, a blockage may exist in the system and will be signaled by ① grease exhaustion at pressure relief valve and ② D0 optical display pin doesn't move.

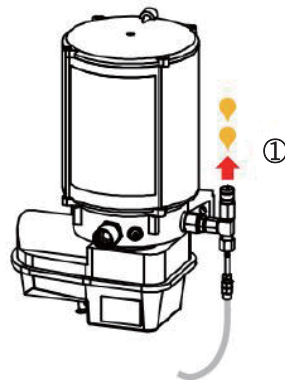

Grease exhaustion at pressure relief valve

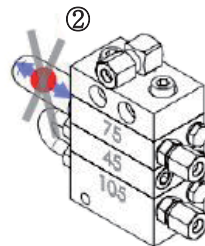

D0 optical display pin

8) IDENTIFICATION OF A POINT OF BLOCKAGE

- (1) Disconnect the main grease hose line from D0 (master) distributor. Actuate the pump and check ① if lubricant supply is effected in correct manner.
- (2) Re-connect the main grease hose line to the D0 distributor. ② Remove the cap screws of the D0 distributor outlet one after another and actuate the pump at each of those steps. The grease lines, pipe or point of lubrication being blocked is in that pipe where pressure is increasing or the optical manual leveling grease gun (XKCE-01419) can't be actuated. After the D0 distributor has been checked and the point of blockage has been detected, the pertaining D1, D2 (secondary) distributor has to be checked up to the point of lubrication, by the same principle of work ③, ④.

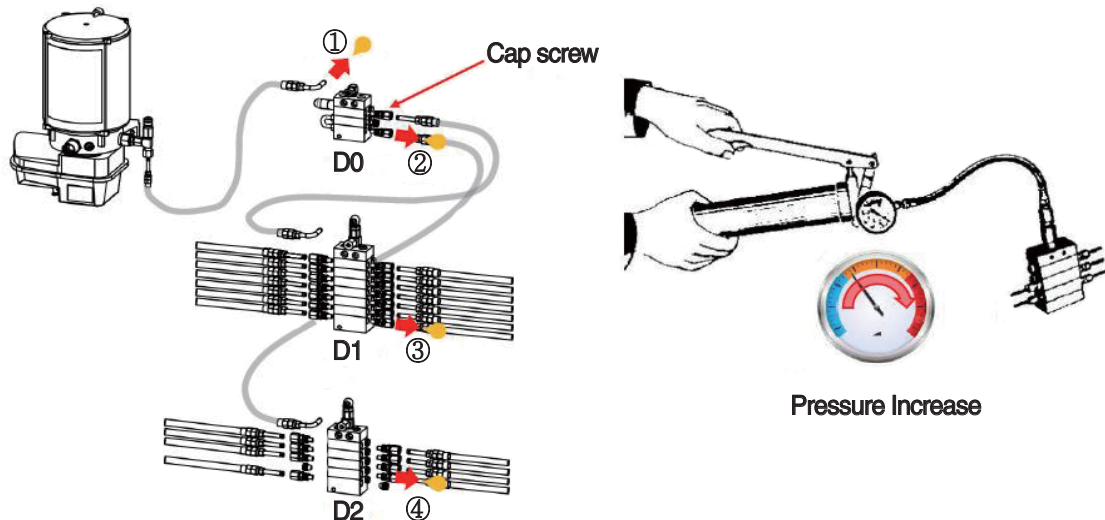

9) HIGH PRESSURE HOSE

Bursting pressure (EN ISO 1402, pressurization : 60s)		Allowed bending radius at 20 °C	Operating pressure reference	
20 °C	60 °C		Statistically	Dynamically
>840 bar	>450 bar	>20 mm	Maximum 280 bar	Maximum 210 bar

(1) Assembly of the high pressure hose

For connecting the high pressure hose with the distributor, you need a threaded ferrule and a ferrule insert on each side of the high pressure hose.

- ① Assembly the high pressure hose with the threaded ferrule

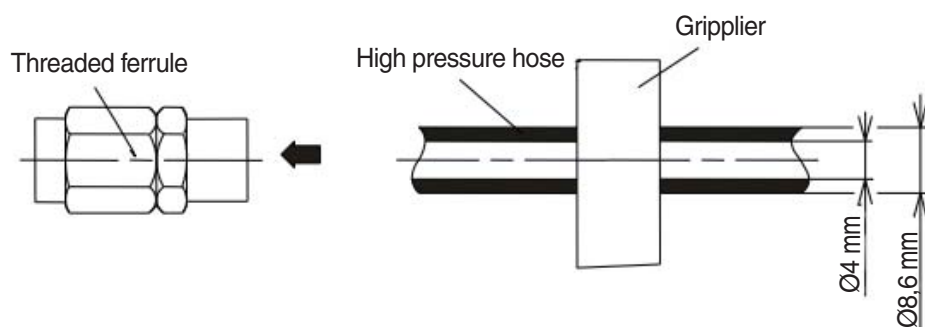

- ② Stick on the high pressure hose with a grippier and grease or oil the end of this very good. The threaded ferrule turn on the hose left-turning up to the dimension in the sketch (11 mm).

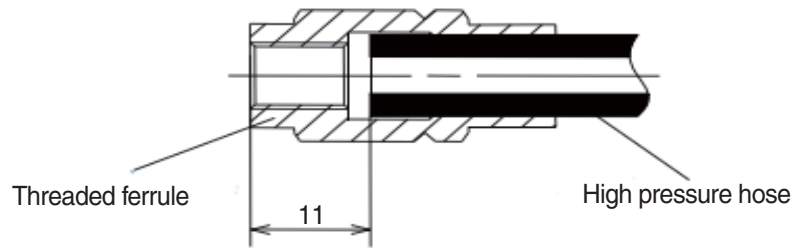

- ③ Assembly the ferrule insert with the threaded ferrule and the high pressur hose : Grease or oil on thread of the ferrule and the conical end of the ferrule insert good and screw the ferrule insert in the assembled ferrule.

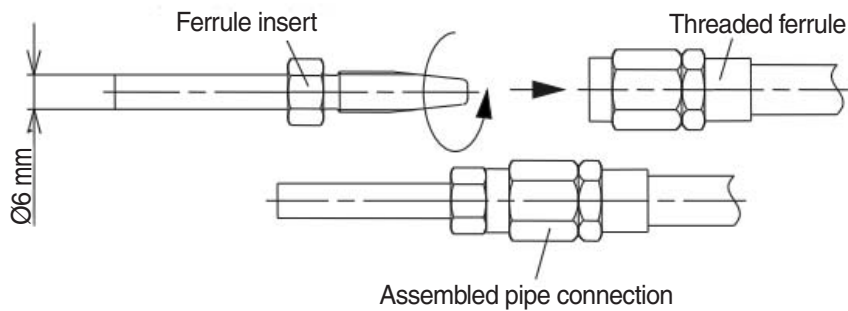

- ※ The dimensions of the hoses are able to differ in a slight range. If the diameter are smaller as standard, the ferrule can be push on the hose without power and without rotary motion.

Remedy :

Press the ferrule on the end for put in the hose in aoval form, about 1 up to 2 mm, with that the hose by screw in the pipe connector not be push out of the ferrule.

10) TROUBLESHOOTING

Category	Applications	Service
Pump does not work	Defective electronic control unit Electric cable is broken Pump is defective	Replace the control unit Renew the electric cable Replace the pump
Pump is working, but does not supply of lubrication	Air in the feed piston filling Grease level dropped below minimum level Defective pump element	Bleed the pump Refill the grease tank Replace the pump element
No grease at all points of lubrication	Pump does not work. Inoperative time is too long or period of lubrication is too short. System is blocked.	Refer to "Pump does not work". Reduce the inoperative time or increase the period of lubrication. Refer to "Excessive pressure (above 265 kgf/cm ²) of the pressure indicator".
No grease at some points of lubrication	Some pipes are burst or leakage Leakage at screwed unions	Renew the pipes Retighten or renew the screwed union
No grease at one point of lubrication	The lubrication pipe is burst or leakage Leakage at screwed unions	Renew the pipe Retighten or renew the screwed union
Reduced pump speed	High pressure in the system Low ambient temperature	Check the system / bearing points Not a defective (1 or 2 intermediate lubrication cycles may be useful)
Excessive pressure (above 265 kgf/cm ²) of the pressure indicator	Excessive pressure in the system Progressive distributor is blocked System is blocked Defective valve spring	Check the system Replace the distributor Repair clogged / seized greasing points Replace the pressure relief valve
Signal of the LED	The LED of control unit is light up continuously	Check electrical system and control unit

11) REFILL GREASE

Use transparent filling press or external grease filling pump

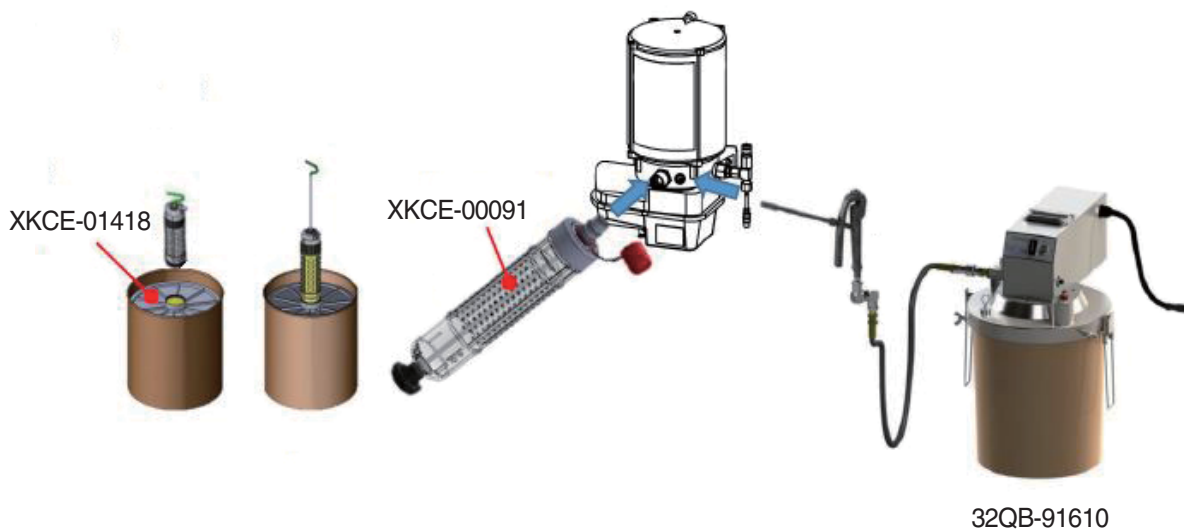

2. QUICK COUPLER

1) FIXING BUCKET WITH QUICK COUPLER

- (1) Release the lock pins by pressing the quick coupler switch on monitor. Buzzer sounds and the red pilot lamp is turned ON.

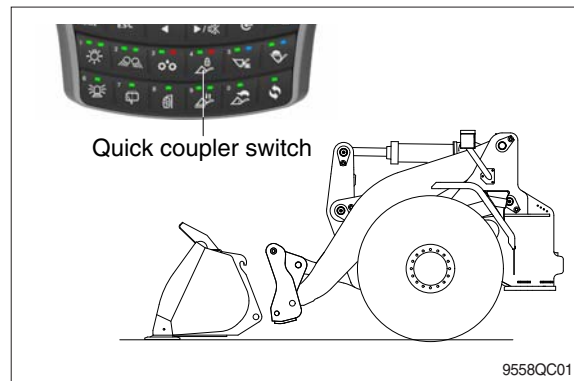

- (2) Tilt quick coupler forward and align the upper attaching points of the quick coupler with upper attaching points on the bucket. Raise the boom until the bucket rests in the quick coupler and tilt the quick coupler rearward until the bucket is level.

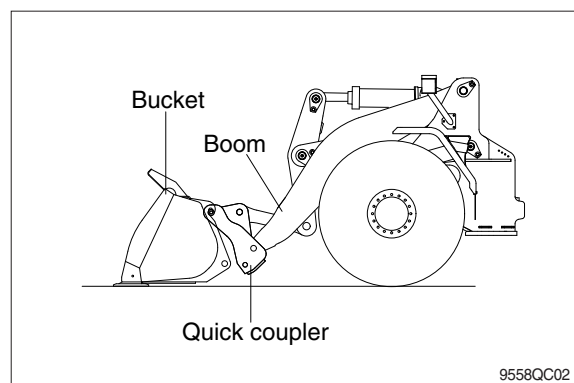

- (3) Lock the bucket with the switch on monitor. The quick coupler pins move in the engaged position and buzzer sounds. The green pilot lamp is turned ON.

※ **Check for engagement as followings.**

- a. Put down pressure on the attachment.
- b. Back up the machine and make sure that there is no movement between the quick coupler and attachment.

※ **Check that the indicator is lock position.**

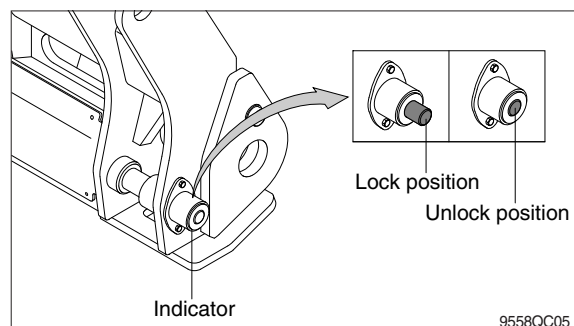
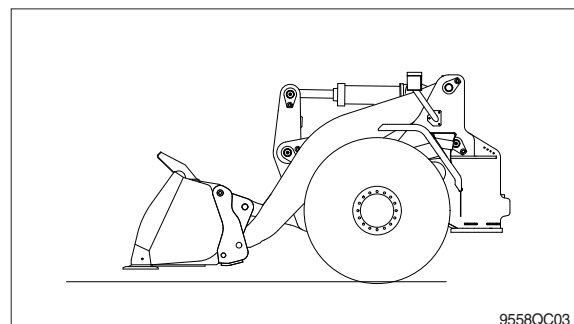

- ▲ Always check that the attachment is properly secured to the quick coupler by pressing the front part of the attachment against the ground.
- ▲ Never use an attachment before you have checked its mounting.
- ※ If you are uncertain if the attachment is securely locked, you must visually check that the lock pins of the quick coupler are in the lock position.

2) REMOVE BUCKET FROM QUICK COUPLER

- (1) The attachment should be in a level position on the ground.
- (2) Release the lock pins by pressing the switch on monitor.
- (3) Lower the boom so that it disengage from the attachment.
- (4) Reverse away from the attachment.

3) PRECAUTION OF USING QUICK COUPLER

- ▲ When operating the machine with quick coupler, confirm that the quick coupler switch is lock position.
Operating the machine with quick clamp switch unlock position can cause the bucket to drop off and bring about the accident.
- ▲ Serious injury or death can result from this accident.



A	
Air cleaner	6-24
Air conditioner & heater	3-53
Air conditioner filter	6-53
Axle oil	6-43
B	
Battery	6-50
Before starting engine	4-2
Belt tensioner	6-23
Boom kick out	4-22
Bucket leveler	4-22
C	
Cab device	3-1
Camera	3-61
Charge air cooler	6-21
Cigar lighter	3-56
Cluster	3-2
Control device	3-49
Coolant level	6-17
D	
DEF/AdBlue® tank	6-27
E	
Engine control module (ECM)	3-61
Engine oil filter	6-15
Engine oil level	6-15
Exhaust system cleaning	4-27
F	
Fan belt	6-22
FNR remote control lever	3-47
Fuel filter	6-26
Fuel prefilter	6-25
Fuse box	3-59
G	
Gear selector lever	3-50
H	
Hydraulic oil changing	6-36
Hydraulic oil filling	6-35
Hydraulic oil level	6-35
J	
Joystick steering control lever	3-51
L	
LCD	3-12
Loading and unloading	5-6
Lubrication	6-48
M	
Machine control unit (MCU)	3-60
Maintenance chart	6-13
Maintenance check list	6-10
Major components	2-1
Master switch	3-58
Monitor	3-13
P	
Pilot cut off switch	3-45
Pilot line filter	6-37
R	
Radiator and oil cooler	6-21
Radio and USB player	3-62
Recommended lubricants	6-9
Return filter	6-36
S	
Safety hints	1-1
Safety labels	0-6
Seat	3-58
Specifications	2-2
Storage	4-25
Switches	3-44
T	
Tightening torque	6-5
Tire	6-38
Towing the machine	5-7
Transmission cold starting	4-6
Transmission control unit (TCU)	3-65
Transmission oil filter	6-41
Transmission oil level	6-41
Transportation	5-1
Travelling machine	4-10
Troubleshooting guide	7-1
W	
Warming up operation	4-8
Weight	2-6
Working method	4-15